

CAP-XX

Thinline Supercapacitors



Product Guide



Contents

1. Key Features	3
2. Typical Applications	3
3. Product Range.....	3
4. Product Specifications	4
5. Storage & Operation Metrics.....	5
6. Energy & Power Density	6
7. Product Markings.....	6
"W" Thinline Products	6
"Z" & "A" Thinline Products	6
8. Batch Code Format.....	7
9. Transportation & Storage.....	7
IATA Dangerous Goods Regulations.....	7
Storage Conditions	7
10. Packaging & Package Quantities.....	7
11. Cautions Before Use.....	7
12. Soldering & Assembly.....	8
Placement.....	8
Soldering.....	8
Washing.....	8
Drying.....	8
Conformal Coatings	9
13. Safety	9
Failure modes	9
Resistance to Shock	9
Resistance to Vibration	10
Drop-Test.....	10
Exposure to an Open Flame	10
Exposure to Heat	10
Pressure.....	11
Puncture.....	11
14. Dimensional Stability & Low Pressure Environments	11
15. Response to Over-Temperature Events.....	11
16. Certifications & Compliances	12
ISO9001-2008.....	12
Underwriter's Laboratory (UL).....	12
RoHS	12
REACH	12
Rare Earth Metals & Conflict Metals	12
Halogens.....	12
17. Product Drawings	13
HZ1xxT Mechanical & Electrical Drawing	13
HA1xxT Mechanical & Electrical Drawing.....	14
HW1xxT Mechanical & Electrical Drawing.....	15
18. Contact Information	16
Principal Office	16
Sales & Product Enquiries	16
Distributors	16
19. Notes & Disclaimers	17

Revision History

Release	Release Date	Author
v0.1	April 16, 2015	Peter Buckle
v0.2	April 18, 2015	Peter Buckle
v0.3	April 18, 2015	Peter Buckle
v0.4	April 20, 2015	Peter Buckle
v0.5	May 3, 2015	Peter Buckle
v0.6	December 17, 2015	Bernd Failenschmid

PRELIMINARY

1. Key Features

- Extremely thin, flexible package (as little as 0.6mm thick)
- The highest power density available today (up to 94kW / litre) and high power output
- Ultra-low ESR (from 45mΩ), even at low temperatures (2x nominal at -40°C)
- High energy density (up to 0.7Wh / litre) and cell voltage (up to 2.75V / cell)
- Wide operating temperature range (from -40°C to +85°C)
- Very low leakage current (typically < 1μA / cell)
- Long cycle life (essentially unlimited) and excellent frequency response
- Environmentally friendly:
RoHS, REACH & WEEE compliant, Lead-free, Halogen-free and Conflict metal-free
- UL and ISO 9001-2008 certified

2. Typical Applications

- Ultra-thin electronic devices, such as active credit cards, RFID tags, beacons and motes, wearable devices (including medical, fitness and health monitoring systems), mobile phones and many other wireless products for industrial, consumer and transportation applications. Power to the IoT.
- **Peak power for pulsed loads**
 - Enable the use of small, low power batteries such as thin film and solid state batteries, Lithium, Silver Oxide and Zinc Air “coin cell” batteries and alkaline batteries.
 - Extend battery run-time and cycle life, especially when the battery is “old or cold”.
 - Support peak loads such as wireless transmissions, haptic feedback/vibration alerts, GPS location, display screen refresh, injection and inhalation systems, etc.
- **Stored energy for low/variable power sources**
 - Enable the use of ambient energy harvesting modules, including solar, vibration, RF, thermoelectric and kinetic.
 - Enable ultra-quick charging times for portable devices and process equipment, via cable, cradle/contacts or induction, maximizing operating time and minimising downtime.
- **Backup power for mission-critical applications**
 - Provide maintenance-free continuous power to mission-critical devices for graceful shutdown and “last gasp” transmission.

3. Product Range

CAP-XX Thinline supercapacitors are available in three sizes. PCB footprints, excluding the aluminium terminals, are:

- “Z” series: 17.0mm x 19.0mm
- “A” series: 19.5mm x 20.0mm
- “W” series: 28.0mm x 20.2mm

All parts are available in 600μm, 700μm and 900μm versions (thicker cells offer higher C and lower ESR).

All parts are available in “H” series (2.75V, 85°C) versions.

Other special order parts are available in “S” footprint and / or “G” series. Contact CAP-XX.

4. Product Specifications

H Series

Voltage & Temperature	Product Name	CAP ² (± 20%) ³	ESR ² (± 20%) ³	Body Size (mm)	Thickness (max)	MOQ / MPQ		
2.75V _{nominal} 2.9V _{peak} -40°C to +70°C T _{max} = 85°C	HZ134T	45 mF	300 mΩ	17.0 x 19.0	0.6 mm	500		
	HZ114T	80 mF	150 mΩ		0.7 mm	500		
	HZ109T	130 mF	100 mΩ		0.9 mm	500		
	-40°C to +70°C T _{max} = 85°C	HA134T	60 mF	220 mΩ	19.5 x 20.0	0.6 mm	500	
		HA114T	120 mF	110 mΩ		0.7 mm	500	
		HA109T	175 mF	75 mΩ		0.9 mm	500	
		-40°C to +70°C T _{max} = 85°C	HW134T	100 mF	130 mΩ	28.5 x 20.2	0.6 mm	500
			HW114T	200 mF	65 mΩ		0.7 mm	500
			HW109T	300 mF	45 mΩ		0.9 mm	500

Parameter	Name	Condition	Minimum	Nominal	Maximum
Leakage Current ³	I _L	23°C		<1μA / cell	<2μA / cell
RMS Current	I _{RMS}	23°C			4A – 7A
Pulse Current ⁴	I _{peak}				30A
ESR change with Temperature	H Series	Min @ +85°C Max @ -40°C	85% of nominal		350% of nominal

Notes:

- Capacitance will decline and ESR will rise over time, at a rate which depends on temperature and voltage. Operation at concurrent high temperature & voltage is not recommended for extended periods. See Section 5 for more information.
- DC capacitance and ESR tolerance are measured at +23°C.
- Leakage current is measured after charging to nominal voltage for 120hrs at +23°C.
- Single pulse, non-repetitive current (positive & negative terminal short-circuited).

5. Storage & Operation Metrics

Parameter	Condition	Metric	H Series	Notes
Operating temperature	Operating temperature range	T_{max} (°C) C loss 1k hrs < 30% ESR rise 1k hrs < 100%	-40°C to +85°C	Brief excursions to T_{max} will not damage the device.
	Maximum continuous operating temperature	T_{cont} (°C) C loss 1k hrs < 30% ESR rise 1k hrs < 100%	+70°C	Continuous operation at T_{max} is not recommended. See Load Life for more information.
Storage	Recommended storage conditions	T_{shelf} (°C)	18°C to +28°C	Store supercapacitors in their original packaging in an air conditioned room.
	Maximum storage temperature & humidity	T_{max} (°C) C loss 1k hrs < 30% ESR rise 1k hrs < 100%	-40°C to +85°C	Storage at high temperature and/or high humidity is not recommended.
		RH_{max} (%)	75%	Storage temperatures must not exceed the maximum rated temp.
Shelf Life	2 years @ 23°C	C loss (% of initial C)	< 10%	Discharged supercapacitors, stored in their original packaging in an air conditioned room.
		ESR rise (% of initial ESR)	< 20%	
Cycle Life	500,000 cycles @ 23°C ($V_n \rightarrow \frac{1}{2}V_n$, $I = 0.5A$)	C loss (% of initial C)	< 5%	Voltage cycling at low RMS current will not affect life.
		ESR rise (% of initial ESR)	< 5%	Cycling at high RMS current will cause self-heating, which will in turn affect life.
Load Life	@ V_n & 23°C H Series = 2.75V, 23°C	C loss rate (% / 1000h)	< 2%	C loss rates & ESR rise rates are drawn from long term life tests. Life tests are conducted over periods of at least 12 months. ESR rise rate is linear. C loss follows an exponential decay.
		ESR rise rate (% of initial / 1000h)	< 2%	
	@ 80% V_n & 80% T_{cont} H Series = 2.3V, 50°C	C loss rate (% / 1000h)	< 3%	
		ESR rise rate (% of initial / 1000h)	< 6%	
	@ V_n & T_{cont} H Series = 2.75V, 70°C	C loss rate (% / 1000h)	< 6%	
		ESR rise rate (% of initial / 1000h)	< 12%	
Time To Failure	@ V_n & 23°C H Series = 2.75V, 23°C	MTTF (years)	> 10	MTTF is calculated with a regression equation (Arrhenius form) from observed failures during long term life testing. Note that such calculations are inaccurate at low temperatures due to low/no observed failures.
	@ 80% V_n & 80% T_{cont} H Series = 2.3V, 50°C	MTTF (years)	3	
	@ V_n & T_{cont} H Series = 2.75V, 70°C	MTTF (years)	< 1	

6. Energy & Power Density

Parameter	Description	Metric	H Series	Notes
Energy	Full discharge from $V_{nominal}$	Capacity (J)	0.17 – 1.13	$E = \frac{1}{2} C \times V^2$
	Gravimetric Energy Density	E_{grav} (Joules/kg)	859 – 1,939	$E_{grav} = (\frac{1}{2} C \times V^2) / \text{Weight}$
		E_{grav} (Wh/kg)	0.24 – 0.54	$E_{grav} = (\frac{1}{2} C \times V^2) / (3600 \times \text{Weight})$
	Volumetric Energy Density	E_{vol} (Wh/L)	0.30 – 0.69	$E_{vol} = (\frac{1}{2} C \times V^2) / (3600 \times \text{Volume})$
Power	Gravimetric Power Density	P_{grav} (kW/kg)	33.0 – 73.9	$P_{grav} = V_n^2 / (4 \times \text{ESR}) / \text{Weight}$
	Volumetric Power Density	P_{vol} (kW/L)	42.1 – 94.1	$P_{vol} = V_n^2 / (4 \times \text{ESR}) / \text{Volume}$

7. Product Markings

CAP-XX Thinline products are marked with the first 5 characters of the Product Name, the nominal Capacitance and Voltage, and the Positive terminal location.

The Batch Code and Device Number are printed on the back of the cell.

The larger footprint “W” products also show the nominal ESR.

“W” Thinline Products

Single cell

Front:

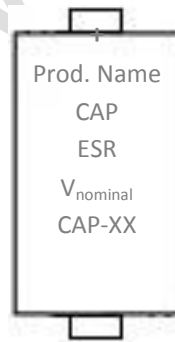

Back:



“Z” & “A” Thinline Products

Single cell

Front:

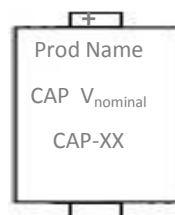

Back:



8. Batch Code Format

CAP-XX products have a 6 character alpha-numeric Batch Code of the form "P2CAJ2", where:

- Position 1: Manufacturing site code
- Position 2: Manufacturing line number
- Position 3: Year of manufacture
- Position 4: Month of manufacture
- Position 5: Day of manufacture
- Position 6: Batch number of the day

The characters at Positions 3 - 6 indicate a number according to the following sequence:

Character	1	2	3	4	5	6	7	8	9	A	B	C	D	E	F	G
Number	1	2	3	4	5	6	7	8	9	10	11	12	13	14	15	16
Character	H	I	J	K	L	M	N	O	P	Q	R	S	T	U	V	
Number	17	18	19	20	21	22	23	24	25	26	27	28	29	30	31	

9. Transportation & Storage

IATA Dangerous Goods Regulations

Supercapacitors with an energy storage capacity of <0.3Wh are not subject to any transportation restrictions (see IATA Dangerous Goods Regulations, 54th Edition, UN3499 in Class 9, Electrical Double-Layer Capacitors).

No CAP-XX small cell supercapacitors have an energy storage capacity >0.3Wh (1,080J), and are therefore not subject to any transportation restrictions.

Storage Conditions

CAP-XX recommends storing supercapacitors prior to assembly in the original packaging, in an air conditioned room at 18°C - 28°C. Storage temperatures must never exceed the maximum operating temperature range specified for the device. Relative humidity should not exceed 75%, with no condensation.

Avoid acidic or alkaline storage environments and any excessive external forces.

10. Packaging & Package Quantities

Packaging for the Thinline series is to be determined.

11. Cautions Before Use

CAP-XX supercapacitors have a defined polarity, shown by the positive terminal marked on the face of the device. Please verify the orientation of the supercapacitor in accordance with the product markings before assembly. Reversing the polarity of the device may cause a small increase in ESR, and will void the warranty.

CAP-XX supercapacitors are heat-sensitive. Over-heating of the supercapacitor may result in a degradation of performance and premature failure.

CAP-XX supercapacitors must only be used within their rated voltage range. Over-voltage may cause swelling and premature product failure.

When connecting two or more cells in series, ensure that the voltage in both cells remains below the rated peak and constant operating voltages. CAP-XX recommends the use of an active balancing circuit or passive balancing resistors to prevent an over-voltage situation developing in one cell. Contact CAP-XX for more information on cell balancing.

CAP-XX supercapacitors are fully discharged when shipped. Devices should be handled and soldered in a discharged state.

12. Soldering & Assembly

Placement

Refer to the Product Drawings for detailed information on the recommended positioning and size of PCB landing pads.

Do not apply excessive force to the supercapacitor during placement. CAP-XX supercapacitors should not be exposed to more than 400kPa pressure across the flat surface of the device (equivalent to a weight of 10kg). Bending or applying too much pressure to the device may damage the seals, resulting in device failure.

Soldering

CAP-XX supercapacitors are NOT SUITABLE for infrared reflow soldering, hot-air reflow soldering, or wave soldering.

CAP-XX Thinline supercapacitor terminals are manufactured from 100µm thick aluminium. These can be attached directly to the PCB by ultrasonic or laser welding, wire bonding, or with an aluminium solder and a manual soldering iron or hot bar soldering jig. A suitable Al solder is Multicore/Loctite 629443.

Do NOT apply solder directly to the device casing. This will cause permanent internal damage to the supercapacitor.

Soldering should be undertaken with a low wattage soldering iron (< 70W), applying heat just long enough to achieve a good connection. The Al soldering process is the same as ordinary soldering: Set the iron at 380C; Coat the Al tabs with Al solder, and the PCB solder pad with ordinary solder; Place the parts on the PCB pads and apply a little more Al solder. The maximum recommended soldering time is 4 sec.

If a hot-air gun is used to reflow the solder during a re-mount or de-mount, care must be taken to prevent excessive heating of the package adjacent to the solder terminals. Allow at least 15 sec between successive soldering attempts for the device to cool down.

Washing

CAP-XX supercapacitors are NOT SUITABLE for solvent-based washing. Do not use any solvent cleaners such as acetone, benzene, isopropyl alcohol or halogenated solvents.

If washing is required after supercapacitor assembly, CAP-XX recommends the use of an aqueous cleaning solution based on de-ionized water to remove any flux residue. Do not wash at temperatures exceeding 70°C, or at spray pressures exceeding 50psi. The supercapacitor may be fully submerged briefly during the washing process, but exposure times to water should generally be minimized.

Drying

Rapid airflow around the device during drying will assist in the removal of any residual moisture trapped in the package. Keep drying times to the minimum necessary, at temperatures not exceeding 70°C.

Conformal Coatings

Some applications require the use of conformal coatings, potting compounds or injection moulded plastics in order to meet specific packaging objectives or performance requirements such as ATEX certification, shock and vibration resistance, waterproofing, and protection from corrosive environments.

Conformal coatings generally involve acrylics, epoxies, polyurethane, silicones, Parylene, or amorphous fluoro polymers, whilst potting/encapsulation may involve the use of thermo-setting plastics, silicone rubber gels, or polyurethanes. In all cases, consideration must be given to the potential for the solvents used in the process to damage the external packaging of the supercapacitor, and to ensure that the maximum temperatures to which the device will be subjected during setting and curing do not exceed its maximum temperature rating. Contact CAP-XX if more information is required.

13. Safety

CAP-XX supercapacitors are very safe and reliable.

Failure modes

The failure mode for a supercapacitor is usually open circuit, with ESR rising to infinity.

This can occur if the device is exposed to high temperature or voltage or as a result of electrolyte loss over time. These situations can occur as a result of assembly errors (e.g. over-heating the device during soldering), circuit design errors (e.g. failure to balance the cell voltages in a dual cell device correctly), environmental extremes (e.g. temperature excursions beyond the specified range or duration), or natural ageing (e.g. permeation of the electrolyte solvent through the package seal).

Occasionally, supercapacitors will fail as a short circuit. This can be due to physical damage sustained during handling or assembly (e.g. if the package is pierced by a sharp, conductive object), assembly errors (e.g. by shorting a terminal to the package during soldering), circuit design errors (e.g. by running vias on the PCB under conductive areas on the package), industrial design errors (e.g. by exerting excessive pressure on the device, damaging the internal separator membrane), or by manufacturing errors (e.g. by misalignment of the separator between electrodes).

Resistance to Shock

CAP-XX has undertaken tests in accordance with IEC60068-2-27 to determine the effects of repeated shocks on both the mechanical integrity and electrical performance of its supercapacitors:

- Pulse Shape Half-Sine
- Amplitude 30g \pm 20%
- Duration 18ms \pm 5%
- No. of Shocks 3 in each direction (18 in total)
- No. of Axes 3, orthogonal

Results: No electrical or mechanical degradation observed.

Note that this test was undertaken on the standard product, with no adhesive mounting tape. To achieve the highest levels of resistance to shock, CAP-XX recommends the use of an adhesive mounting tape on the underside of the device.

Resistance to Vibration

CAP-XX has undertaken tests in accordance with IEC60068-2-6 to determine the effects of sustained vibration on both the mechanical integrity and electrical performance of its supercapacitors:

- Type Sinusoidal
- Frequency 55Hz - 500Hz
- Amplitude 0.35mm \pm 3dB (55Hz to 59.55Hz)
5g \pm 3dB (59.55Hz to 500Hz)
- Sweep Rate 1 Oct/min
- No. of Cycles 10 (55Hz - 500Hz - 55Hz)
- No. of Axes 3, orthogonal

Results: No electrical or mechanical degradation observed.

Note that this test was undertaken on the standard product, with no adhesive mounting tape. To achieve the highest levels of resistance to vibration, CAP-XX recommends the use an adhesive mounting tape on the underside of the device.

Drop-Test

CAP-XX has undertaken tests to determine the effects of repeated drops on both the mechanical integrity and electrical performance of its supercapacitors:

- Mounting Mount the supercapacitor in a test jig as set out below
- Method Drop the test jig onto a concrete floor from a height of 2m
- No. of Cycles 3 drops, one on each axis

Results: No electrical or mechanical degradation observed when following the mounting rules.

Mounting during drop test:

- Constrained by the device housing, with a maximum clearance of 1mm – The supercapacitor was connected to the PCB only by the solder connections on the terminals.
- Unconstrained by the device housing - The supercapacitor was connected to the PCB with double-sided adhesive tape and by solder connections on all terminals.

For maximum product performance in harsh environments, CAP-XX recommends the use of an adhesive mounting tape on the underside of the device or a conformal coating/potting compound.

Exposure to an Open Flame

A fully charged supercapacitor was burned with an alcohol lamp.

Results: The supercapacitor expands due to the heat, and the seal weakens, but does not burst. There is no ignition, no fire, and no scattering of pieces and/or sparks.



Exposure to Heat

A fully charged supercapacitor was placed in an oven for 1hr at 130°C.

Results: The supercapacitor expands due to the heat, and the seal weakens, but does not burst. There is no smoke, no fire, and no gas emission.



Pressure

A fully charged supercapacitor was pressed with a 10mm diameter pole, to 2/3 of its initial thickness.

Results: The supercapacitor loses its charge. There is no ignition, no smoke, no fire, no gas emission, and no scattering of pieces and/or sparks.



Puncture

A fully charged supercapacitor was punctured with a 2mm diameter steel needle.

Results: The supercapacitor loses its charge. There is no ignition, no smoke, no fire, no gas emission, and no scattering of pieces and/or sparks.

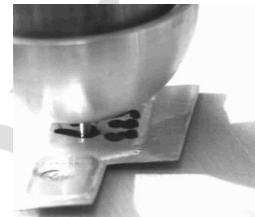

14. Dimensional Stability & Low Pressure Environments

CAP-XX supercapacitors are hermetically sealed, and contain a very small amount of a liquid electrolyte. At high altitudes (with low external pressure), the device may swell and ESR may increase. Contact CAP-XX for more information on use in low pressure environments.

The aluminium soft pack will swell at high temperature, and may exert force on adjacent components. If unconstrained, the device may swell by up to 50% of its nominal thickness at 70°C.

If constrained by the device housing or adjacent components, the supercapacitor may exert up to 7N of force on its surroundings at 70°C. As an example, with a contact surface area of 1.7cm², a single cell W device will exert a pressure of ~20kPa (3psi) on a fixed surface at 70°C.

15. Response to Over-Temperature Events

CAP-XX supercapacitors are heat-sensitive.

Over-heating the supercapacitor may result in a degradation of performance and useful life. Note that the thermal mass of a CAP-XX supercapacitor is very small, so its temperature will adjust to environmental changes very quickly.

H series are rated to 85°C. CAP-XX does not recommend operating supercapacitors at or near their maximum temperature rating for extended periods of time, as they will age rapidly (ESR will rise and capacitance will fall).

Exceeding the rated maximum temperature will cause even more accelerated ageing, and may cause immediate failure depending on the temperature reached and the time exposed.

At temperatures between 85°C and 100°C, there will be a progressive change in the dimensions of the package (puffing). Usually, this is reversible, and electrical performance is retained. As the temperature approaches 100°C, the probability of non-reversible change increases. This will occasionally cause immediate failure, and degraded electrical performance due to physical damage to the internal structure of the device.

At temperatures greater than 100°C, electrical performance will degrade rapidly, and permanent electrical failure becomes increasingly likely. At 150°C or higher, the seals will melt and the device will fail both physically and electrically.

16. Certifications & Compliances

ISO9001-2008

CAP-XX is certified as following the ISO 9001 Quality Management System. The current certification can be found by typing "CAP-XX" in the Organisation field of the Certified Organisations Search page of the JAS-ANZ Register at cab.jas-anz.org.

Underwriter's Laboratory (UL)

All CAP-XX standard products have been tested by Underwriter's Laboratory and are certified as UL-Recognized Components. The CAP-XX certified products can be found under UL category code BBBG2, and UL file number MH47599 in the Online Certifications Directory at database.ul.com.

RoHS

All CAP-XX products are RoHS compliant. Substances specified in the European Union directive 2011/65/EU and Chinese Government directive (to standard SJ/T 11363 – 2006) are either not present at all, or are present at levels below those specified in the directive.

The current RoHS Certificate of Compliance is available on the [CAP-XX website](#).

REACH

All CAP-XX products are REACH compliant.

Pre-registration and registration of substances in articles: CAP-XX does not supply any products that would be considered an article with a substance intended to be released during normal and reasonably foreseeable conditions of use, and therefore has no plans for pre-registration.

Substances of Very High Concern (SVHC): CAP-XX products do not contain any chemicals listed as SVHC in Annex XIV or the Candidate List under Article 57 of European Directive EC 1907/2006 and as amended by subsequent regulations.

Restricted use substances: CAP-XX products either do not contain any of the restricted-use substances given in Annex XVII of European Directive EC 1907/2006 and as amended by subsequent regulations, or meet any of the restrictions placed on them.

The current REACH Certificate of Compliance is available on the [CAP-XX website](#).

Rare Earth Metals & Conflict Metals

CAP-XX products do not contain any rare earth metals or conflict metals as defined in Section 1502 of the United States Financial Reform Bill (HR 4173), 2010.

Specifically, CAP-XX supercapacitors do not contain any Tantalum (Ta), Tungsten (W) or Gold (Au). CAP-XX products contain Tin (Sn) sourced only from non-conflict sources.

The current Certificate of Compliance is available on the [CAP-XX website](#).

Halogens

CAP-XX products are halogen-free as defined under the draft IPC/JEDEC J-STD-709 standard for electronic components and assemblies. Specifically, CAP-XX products do not contain any brominated or chlorinated flame retardants (BFRs/CFRs) or PVC plastics.

The current Certificate of Compliance is available on the [CAP-XX website](#).

17. Product Drawings

HZ1xxT Mechanical & Electrical Drawing

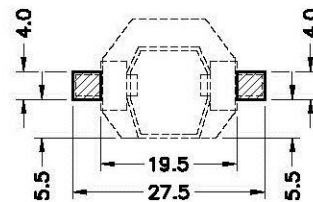
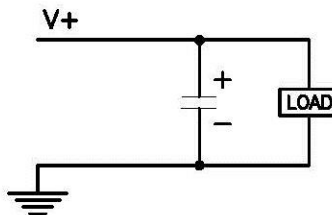
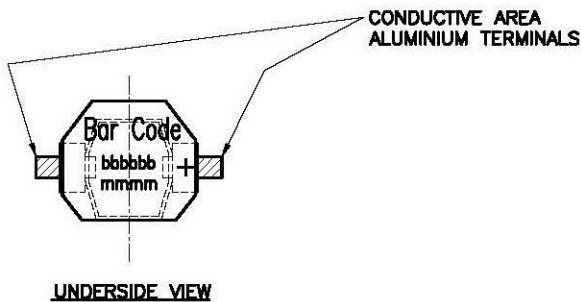
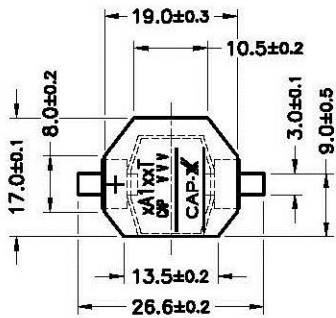

SUGGESTED PAD LAYOUT
 CUSTOMERS SHOULD DETERMINE
 FINAL PAD SIZE AND PLACEMENT
 BASED ON THEIR
 MANUFACTURING TOLERANCES

HA1xxT Mechanical & Electrical Drawing

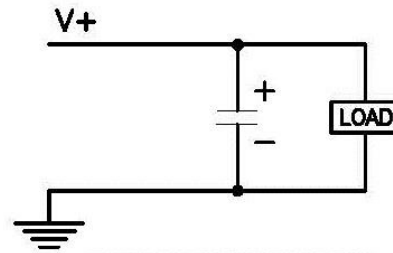
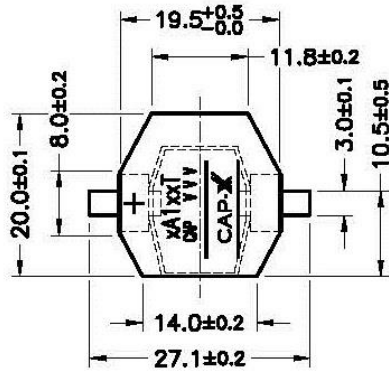

**SUGGESTED CONNECTION
DETAILS FOR SINGLE CELL
SUPERCAP**

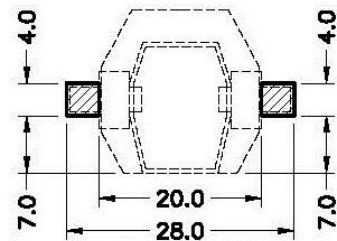
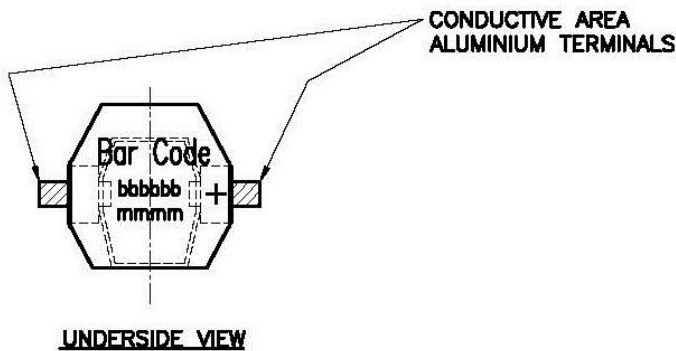

SUGGESTED PAD LAYOUT

**CUSTOMERS SHOULD DETERMINE
FINAL PAD SIZE AND PLACEMENT
BASED ON THEIR
MANUFACTURING TOLERANCES**



HW1xxT Mechanical & Electrical Drawing

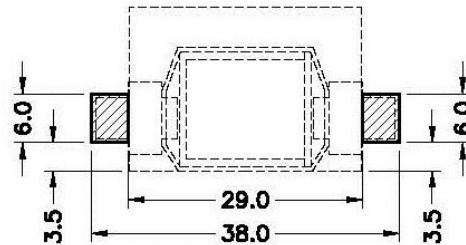
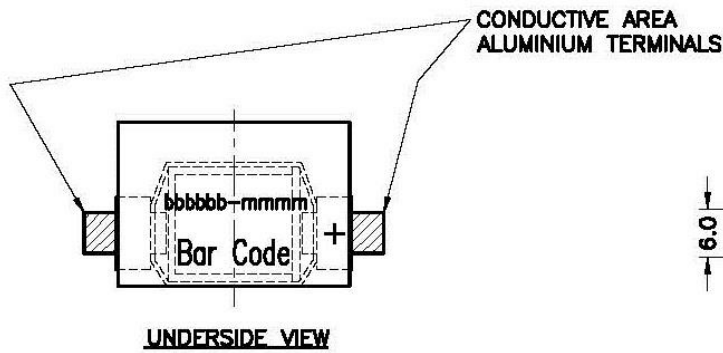
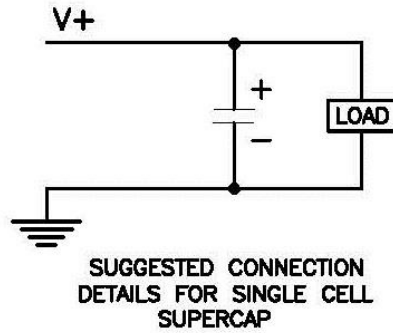
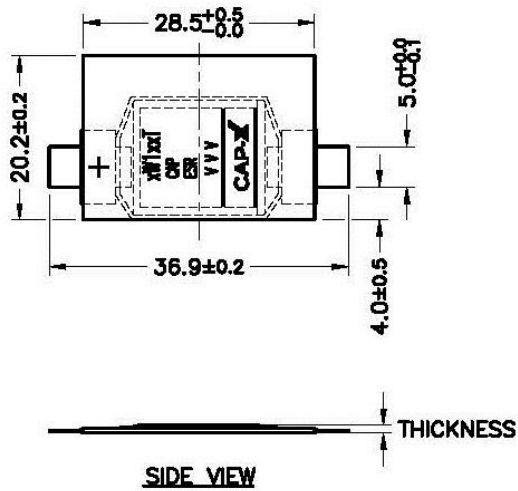

SUGGESTED PAD LAYOUT

**CUSTOMERS SHOULD DETERMINE
FINAL PAD SIZE AND PLACEMENT
BASED ON THEIR
MANUFACTURING TOLERANCES**



18. Contact Information

Principal Office

CAP-XX (Australia) Pty Ltd
 Unit 9, 12 Mars Road
 Lane Cove, NSW 2066
 Australia

Sales & Product Enquiries

Website: www.cap-xx.com
 Email: sales@cap-xx.com
 Telephone: +61 2 9420 0690

Distributors

AMERICAS

Tecate Industries www.tecategroup.com

ASIA

ASEAN & South Asia	McCoy Components	www.mccoycomponents.com
China	King Horn Enterprises	www.kinghornhk.com/en/
	Weikeng International	www.weikeng.com.cn/
Japan	Synerdyne	www.syr.co.jp
Korea	Contact CAP-XX	www.cap-xx.com
India	Elektronika Sales	www.elektronikasales.com
Taiwan	Longview Technology	www.wpi-group.com/lvt

EUROPE

Denmark	ACTE Denmark	www.acte.dk
Finland	ACTE Finland	www.acte.fi
France & Benelux	CATS	www.cats-france.fr
Germany, Austria & Switzerland	Unitronic	www.unitronic.de
Norway	ACTE Norway	www.acte.no
Poland & Russia	ACTE Poland	www.acte.pl
Spain & Portugal	ELCO Componentes	www.elcocomponentes.com
Sweden	ACTE Sweden	www.acte.se
UK & Ireland	ACTE UK	www.acte-uk.com

MIDDLE EAST & AFRICA

Israel	B. Roman (2001)	www.broman.co.il
South Africa	Seven Labs Technology	www.sevenlabs.co.za

19. Notes & Disclaimers

Product specifications in this document are current as of the date of this document. Specifications are subject to change, and products may be discontinued without advance notice.

This document contains limited specification detail. Please review the relevant Data Sheet or contact CAP-XX for more information about specific products.

CAP-XX products are not authorized for use in medical devices classified as Class III under the European Union Directive 93/42/EC, 2010, or Class D of the Global Harmonization Task Force Guidelines, 2012. Please contact CAP-XX for more information on the use of our products in any applications which may be considered to carry any risk of harm to people or property.

CAP-XX and trade names associated with CAP-XX are protected by Trademark.

Technology referred to in this document is protected by US patent 06631072 and other patents and pending patent.

PRELIMINARY