

## Type 204

(No.P-204-E002)

Type 204 is a highly reliable epoxy resin coating tantalum solid electrolytic capacitor.

## FEATURES

1. High reliability and small size.
2. Usable at operating temperature range  $-55 \sim +125^{\circ}\text{C}$ .
3. Packaging(Reel and Ammo) is available for automatic insertion (up to case code 8).
4. Available for capacitance tolerance code "J"( $\pm 5\%$ ).
5. Available for Lead-free and RoHS Compliant.

## RATING

Item	Description
Operating temperature	$-55$ to $+125^{\circ}\text{C}$
Maximum operating temperature for DC rated voltage	$+85^{\circ}\text{C}$ <sup>(1)</sup>
DC rated voltage range ( $U_R$ )	See CATALOG NUMBERS AND RATING OF STANDARD PRODUCTS
Nominal capacitance range ( $C_R$ )	
Capacitance tolerance	
Failure rate level	Type 204 M series: 1%/1000h
	Type 204 N series: 0.5%/1000h <sup>(2)</sup>

Note<sup>(1)</sup>: For operation  $125^{\circ}\text{C}$ , derate voltage linearly to 67% of  $85^{\circ}\text{C}$  voltage rating.

Note<sup>(2)</sup>: Failure rate level 0.5%/1000h(Code N) is available for rated voltage up to 35V, case size code 10 or less.

## ORDERING INFORMATION

204 TYPE		N SERIES		1602 RATED VOLTAGE		106 CAPACITANCE		M CAPACITANCE TOLERANCE		B STYLE OF REELED PACKAGE		F COMPLIANCE WITH ROHS DIRECTIVE	
Marking	Series	Marking	Rated voltage	Marking	Capacitance	Marking	Capacitance	Marking	Capacitance Tolerance	Marking	Lead style or style of packing	Marking	RoHS compliance
M	Failure rate level 1%/1000h	3151	3.15VDC	104	0.1 $\mu\text{F}$	106	10 $\mu\text{F}$	K	$\pm 10\%$	3	Hockey Stick	-	Not compliant
N	Failure rate level 0.5%/1000h	6301	6.3VDC	154	0.15 $\mu\text{F}$	156	15 $\mu\text{F}$	M	$\pm 20\%$	4	Straight Lead	F	Compliant
		1002	10VDC	224	0.22 $\mu\text{F}$	226	22 $\mu\text{F}$			B	Ammo Package		
		1602	16VDC	334	0.33 $\mu\text{F}$	336	33 $\mu\text{F}$			C	Reel Package		
		2002	20VDC	474	0.47 $\mu\text{F}$	476	47 $\mu\text{F}$						
		2502	25VDC	684	0.68 $\mu\text{F}$	686	68 $\mu\text{F}$						
		3502	35VDC	105	1.0 $\mu\text{F}$	107	100 $\mu\text{F}$						
		5002	50VDC	155	1.5 $\mu\text{F}$	157	150 $\mu\text{F}$						
				225	2.2 $\mu\text{F}$	227	220 $\mu\text{F}$						
				335	3.3 $\mu\text{F}$	337	330 $\mu\text{F}$						
				475	4.7 $\mu\text{F}$	477	470 $\mu\text{F}$						
				685	6.8 $\mu\text{F}$								

## DIMENSIONS

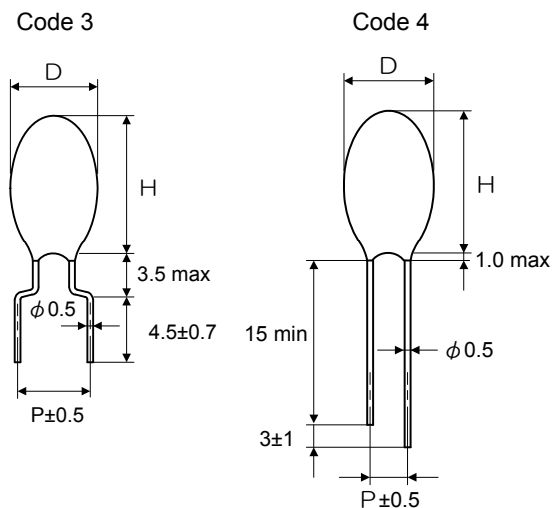

Case code	$\phi D$ max	H max	P $\pm 0.5$	
			Code 3	Code 4
1	3.6	6.5	5.0	2.5
2	3.8	7.0	5.0	2.5
3	4.0	7.5	5.0	2.5
4	4.8	8.0	5.0	2.5
5	5.0	8.5	5.0	2.5
6	5.5	9.5	5.0	2.5
7	6.0	10.0	5.0	2.5
8	6.5	11.5	5.0	2.5
9	7.5	13.0	5.0	5.0
10	8.0	14.0	5.0	5.0
11 <sup>(1)</sup>	8.5	20.0	5.0	5.0

Note <sup>(1)</sup>: Case code 11's Dimension H includes resin coating of lead wire.

## MARKING

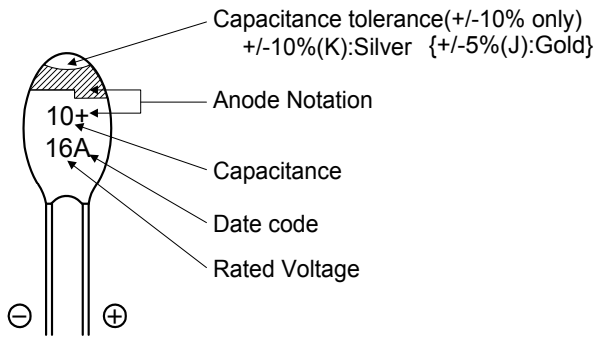

## STANDARD RATING

R.V.(VDC) Cap.(μF)	3.15	6.3	10	16	20	25	35	50
0.1							1	2
0.15							1	2
0.22							1	2
0.33							1	2
0.47							1	2
0.68							1	2
1.0							1	3
1.5						1	2	4
2.2					1	2	3	5
3.3				1	2	3	4	6
4.7			1	2	3	4	5	7
6.8		1	2	3	4	5	6	8
10	1	2	3	4	5	6	7	9
15	2	3	4	5	6	7	8	10
22	3	4	5	6	7	8	9	11
33	4	5	6	7	8	9	10	
47	5	6	7	8	9	10	11	
68	6	7	8	9	10	11		
100	7	8	9	10	11			
150	8	9	10	11				
220	9	10	11					
330	10	11						
470	11							

**CATALOG NUMBERS AND RATING OF STANDARD PRODUCTS**

Dec, 2014

Catalog Number <sup>(1)</sup> <sub>(2)</sub> <sup>(3)</sup> <sub>(4)</sub> <sup>(5)</sup>	U <sub>R</sub> VDC	U <sub>S</sub> VDC	C <sub>R</sub> μF	Case code	Leakage current(DCL) μA			Dissipation factor			
					20°C	85°C	125°C	-55°C	20°C	85°C	125°C
204 <sub>1</sub> 3151 106 <sub>2 3 5</sub>	3.15	4	10	1	0.5	5	6.3	0.08	0.06	0.06	0.06
204 <sub>1</sub> 3151 156 <sub>2 3 5</sub>			15	2	0.5	5	6.3	↓	↓	↓	↓
204 <sub>1</sub> 3151 226 <sub>2 3 5</sub>			22	3	0.7	7	8.7	↓	↓	↓	↓
204 <sub>1</sub> 3151 336 <sub>2 3 5</sub>			33	4	1.0	10	13	↓	↓	↓	↓
204 <sub>1</sub> 3151 476 <sub>2 3 5</sub>			47	5	1.5	15	19	↓	↓	↓	↓
204 <sub>1</sub> 3151 686 <sub>2 3 5</sub>			68	6	2.1	21	27	↓	↓	↓	↓
204 <sub>1</sub> 3151 107 <sub>2 3 5</sub>			100	7	3.2	32	39	0.10	0.08	0.08	0.08
204 <sub>1</sub> 3151 157 <sub>2 3 5</sub>			150	8	4.7	47	59	↓	↓	↓	↓
204 <sub>1</sub> 3151 227 <sub>2 4 5</sub>			220	9	7.0	70	100	↓	↓	↓	↓
204 <sub>1</sub> 3151 337 <sub>2 4 5</sub>			330	10	10	100	130	↓	↓	↓	↓
204M 3151 477 <sub>2 4 5</sub>			↓	↓	470	11	15	150	185	0.12	0.10
204 <sub>1</sub> 6301 685 <sub>2 3 5</sub>	6.3	8.0	6.8	1	0.5	5	6.3	0.08	0.06	0.06	0.06
204 <sub>1</sub> 6301 106 <sub>2 3 5</sub>			10	2	0.6	6	7.9	↓	↓	↓	↓
204 <sub>1</sub> 6301 156 <sub>2 3 5</sub>			15	3	0.9	9	12	↓	↓	↓	↓
204 <sub>1</sub> 6301 226 <sub>2 3 5</sub>			22	4	1.4	14	17	↓	↓	↓	↓
204 <sub>1</sub> 6301 336 <sub>2 3 5</sub>			33	5	2.1	21	26	↓	↓	↓	↓
204 <sub>1</sub> 6301 476 <sub>2 3 5</sub>			47	6	3.0	30	37	↓	↓	↓	↓
204 <sub>1</sub> 6301 686 <sub>2 3 5</sub>			68	7	4.3	43	54	↓	↓	↓	↓
204 <sub>1</sub> 6301 107 <sub>2 3 5</sub>			100	8	6.3	63	79	0.10	0.08	0.08	0.08
204 <sub>1</sub> 6301 157 <sub>2 4 5</sub>			150	9	9.5	95	118	↓	↓	↓	↓
204 <sub>1</sub> 6301 227 <sub>2 4 5</sub>			220	10	14	140	173	↓	↓	↓	↓
204M 6301 337 <sub>2 4 5</sub>			↓	↓	330	11	21	210	260	↓	↓
204 <sub>1</sub> 1002 475 <sub>2 3 5</sub>	10	13	4.7	1	0.5	5	6.3	0.08	0.06	0.06	0.06
204 <sub>1</sub> 1002 685 <sub>2 3 5</sub>			6.8	2	0.7	7	8.5	↓	↓	↓	↓
204 <sub>1</sub> 1002 106 <sub>2 3 5</sub>			10	3	1.0	10	13	↓	↓	↓	↓
204 <sub>1</sub> 1002 156 <sub>2 3 5</sub>			15	4	1.5	15	19	↓	↓	↓	↓
204 <sub>1</sub> 1002 226 <sub>2 3 5</sub>			22	5	2.2	22	28	↓	↓	↓	↓
204 <sub>1</sub> 1002 336 <sub>2 3 5</sub>			33	6	3.3	33	41	↓	↓	↓	↓
204 <sub>1</sub> 1002 476 <sub>2 3 5</sub>			47	7	4.7	47	59	↓	↓	↓	↓
204 <sub>1</sub> 1002 686 <sub>2 3 5</sub>			68	8	6.8	68	85	↓	↓	↓	↓
204 <sub>1</sub> 1002 107 <sub>2 4 5</sub>			100	9	10	100	125	0.10	0.08	0.08	0.08
204 <sub>1</sub> 1002 157 <sub>2 4 5</sub>			150	10	15	150	188	↓	↓	↓	↓
204M 1002 227 <sub>2 4 5</sub>			↓	↓	220	11	22	220	275	↓	↓
204 <sub>1</sub> 1602 335 <sub>2 3 5</sub>	16	20	3.3	1	0.5	5	6.6	0.08	0.06	0.06	0.06
204 <sub>1</sub> 1602 475 <sub>2 3 5</sub>			4.7	2	0.8	8	9.4	↓	↓	↓	↓
204 <sub>1</sub> 1602 685 <sub>2 3 5</sub>			6.8	3	1.1	11	14	↓	↓	↓	↓
204 <sub>1</sub> 1602 106 <sub>2 3 5</sub>			10	4	1.6	16	20	↓	↓	↓	↓
204 <sub>1</sub> 1602 156 <sub>2 3 5</sub>			15	5	2.4	24	30	↓	↓	↓	↓
204 <sub>1</sub> 1602 226 <sub>2 3 5</sub>			22	6	3.5	35	44	↓	↓	↓	↓
204 <sub>1</sub> 1602 336 <sub>2 3 5</sub>			33	7	5.3	53	66	↓	↓	↓	↓
204 <sub>1</sub> 1602 476 <sub>2 3 5</sub>			47	8	7.5	75	94	↓	↓	↓	↓
204 <sub>1</sub> 1602 686 <sub>2 4 5</sub>			68	9	11	110	136	↓	↓	↓	↓
204 <sub>1</sub> 1602 107 <sub>2 4 5</sub>			100	10	16	160	200	0.10	0.08	0.08	0.08
204M 1602 157 <sub>2 4 5</sub>			↓	↓	150	11	24	240	300	↓	↓
204 <sub>1</sub> 2002 225 <sub>2 3 5</sub>	20	25	2.2	1	0.5	5	6.3	0.08	0.06	0.06	0.06
204 <sub>1</sub> 2002 335 <sub>2 3 5</sub>			3.3	2	0.7	7	8.3	↓	↓	↓	↓
204 <sub>1</sub> 2002 475 <sub>2 3 5</sub>			4.7	3	0.9	9	12	↓	↓	↓	↓
204 <sub>1</sub> 2002 685 <sub>2 3 5</sub>			6.8	4	1.4	14	17	↓	↓	↓	↓
204 <sub>1</sub> 2002 106 <sub>2 3 5</sub>			10	5	2.0	20	25	↓	↓	↓	↓
204 <sub>1</sub> 2002 156 <sub>2 3 5</sub>			15	6	3.0	30	38	↓	↓	↓	↓
204 <sub>1</sub> 2002 226 <sub>2 3 5</sub>			22	7	4.4	44	55	↓	↓	↓	↓
204 <sub>1</sub> 2002 336 <sub>2 3 5</sub>			33	8	6.6	66	83	↓	↓	↓	↓
204 <sub>1</sub> 2002 476 <sub>2 4 5</sub>			47	9	9.4	94	118	↓	↓	↓	↓
204 <sub>1</sub> 2002 686 <sub>2 4 5</sub>			68	10	14	140	170	↓	↓	↓	↓
204M 2002 107 <sub>2 4 5</sub>			↓	↓	100	11	20	200	250	0.10	0.08

Catalog Number <sup>(1)</sup> <sup>(2)</sup> <sup>(3)</sup> <sup>(4)</sup> <sup>(5)</sup>	U <sub>R</sub> VDC	U <sub>S</sub> VDC	C <sub>R</sub> μF	Case code	Leakage current(DCL) μA			Dissipation factor			
					20°C	85°C	125°C	-55°C	20°C	85°C	125°C
204 <sub>1</sub> 2502 155 <sub>2 3 5</sub>	25	32	1.5	1	0.5	5	6.3	0.08	0.06	0.06	0.06
204 <sub>1</sub> 2502 225 <sub>2 3 5</sub>			2.2	2	0.6	6	6.9	↓	↓	↓	↓
204 <sub>1</sub> 2502 335 <sub>2 3 5</sub>			3.3	3	0.8	8	10	↓	↓	↓	↓
204 <sub>1</sub> 2502 475 <sub>2 3 5</sub>			4.7	4	1.2	12	15	↓	↓	↓	↓
204 <sub>1</sub> 2502 685 <sub>2 3 5</sub>			6.8	5	1.7	17	21	↓	↓	↓	↓
204 <sub>1</sub> 2502 106 <sub>2 3 5</sub>			10	6	2.5	25	31	↓	↓	↓	↓
204 <sub>1</sub> 2502 156 <sub>2 3 5</sub>			15	7	3.8	38	47	↓	↓	↓	↓
204 <sub>1</sub> 2502 226 <sub>2 3 5</sub>			22	8	5.5	55	69	↓	↓	↓	↓
204 <sub>1</sub> 2502 336 <sub>2 4 5</sub>			33	9	8.3	83	103	↓	↓	↓	↓
204 <sub>1</sub> 2502 476 <sub>2 4 5</sub>			47	10	12	120	147	↓	↓	↓	↓
204M 2502 686 <sub>2 4 5</sub>			68	11	17	170	213	↓	↓	↓	↓
204 <sub>1</sub> 3502 104 <sub>2 3 5</sub>	35	44	0.1	1	0.5	5	6.3	0.05	0.04	0.04	0.05
204 <sub>1</sub> 3502 154 <sub>2 3 5</sub>			0.15	1	0.5	5	6.3	↓	↓	↓	↓
204 <sub>1</sub> 3502 224 <sub>2 3 5</sub>			0.22	1	0.5	5	6.3	↓	↓	↓	↓
204 <sub>1</sub> 3502 334 <sub>2 3 5</sub>			0.33	1	0.5	5	6.3	↓	↓	↓	↓
204 <sub>1</sub> 3502 474 <sub>2 3 5</sub>			0.47	1	0.5	5	6.3	↓	↓	↓	↓
204 <sub>1</sub> 3502 684 <sub>2 3 5</sub>			0.68	1	0.5	5	6.3	↓	↓	↓	↓
204 <sub>1</sub> 3502 105 <sub>2 3 5</sub>			1.0	1	0.5	5	6.3	↓	↓	↓	↓
204 <sub>1</sub> 3502 155 <sub>2 3 5</sub>			1.5	2	0.5	5	6.6	0.08	0.06	0.06	0.06
204 <sub>1</sub> 3502 225 <sub>2 3 5</sub>			2.2	3	0.8	8	9.6	↓	↓	↓	↓
204 <sub>1</sub> 3502 335 <sub>2 3 5</sub>			3.3	4	1.2	12	14	↓	↓	↓	↓
204 <sub>1</sub> 3502 475 <sub>2 3 5</sub>			4.7	5	1.6	16	21	↓	↓	↓	↓
204 <sub>1</sub> 3502 685 <sub>2 3 5</sub>	6.8	6	2.4	24	30	↓	↓	↓	↓		
204 <sub>1</sub> 3502 106 <sub>2 3 5</sub>	10	7	3.5	35	44	↓	↓	↓	↓		
204 <sub>1</sub> 3502 156 <sub>2 3 5</sub>	15	8	5.3	53	66	↓	↓	↓	↓		
204 <sub>1</sub> 3502 226 <sub>2 4 5</sub>	22	9	7.7	77	96	↓	↓	↓	↓		
204 <sub>1</sub> 3502 336 <sub>2 4 5</sub>	33	10	12	120	144	↓	↓	↓	↓		
204M 3502 476 <sub>2 4 5</sub>	47	11	16	160	206	↓	↓	↓	↓		
204M 5002 104 <sub>2 3 5</sub>	50	63	0.10	2	0.5	5	6.3	0.05	0.04	0.04	0.05
204M 5002 154 <sub>2 3 5</sub>			0.15	2	0.5	5	6.3	↓	↓	↓	↓
204M 5002 224 <sub>2 3 5</sub>			0.22	2	0.5	5	6.3	↓	↓	↓	↓
204M 5002 334 <sub>2 3 5</sub>			0.33	2	0.5	5	6.3	↓	↓	↓	↓
204M 5002 474 <sub>2 3 5</sub>			0.47	2	0.5	5	6.3	↓	↓	↓	↓
204M 5002 684 <sub>2 3 5</sub>			0.68	2	0.5	5	6.3	↓	↓	↓	↓
204M 5002 105 <sub>2 3 5</sub>			1.0	3	0.5	5	6.3	↓	↓	↓	↓
204M 5002 155 <sub>2 3 5</sub>			1.5	4	0.8	8	9.4	0.08	0.06	0.06	0.06
204M 5002 225 <sub>2 3 5</sub>			2.2	5	1.1	11	14	↓	↓	↓	↓
204M 5002 335 <sub>2 3 5</sub>			3.3	6	1.7	17	21	↓	↓	↓	↓
204M 5002 475 <sub>2 3 5</sub>			4.7	7	2.4	24	29	↓	↓	↓	↓
204M 5002 685 <sub>2 3 5</sub>	6.8	8	3.4	34	43	↓	↓	↓	↓		
204M 5002 106 <sub>2 4 5</sub>	10	9	5.0	50	63	↓	↓	↓	↓		
204M 5002 156 <sub>2 4 5</sub>	15	10	7.5	75	94	↓	↓	↓	↓		
204M 5002 226 <sub>2 4 5</sub>	22	11	11	110	138	↓	↓	↓	↓		

\*U<sub>R</sub> = Rated Voltage U<sub>S</sub> = Surge Voltage C<sub>R</sub> = Capacitance

Note <sup>(1)</sup>: series code "M" or "N".

Note <sup>(2)</sup>: capacitance tolerance code "K" or "M".

Note <sup>(3)</sup>: lead style (3 or 4) or packaging style code (B or C).

Note <sup>(4)</sup>: lead style (3 or 4)

Note <sup>(5)</sup>: for RoHS compliant, insert "F"

## PERFORMANCE

No.	Item		Performance	Test method
1	Leakage Current (µA)		Shall not exceed 0.01 CV or 0.5 whichever is greater.	JIS C 5101-1, 4.9 Applied Voltage : Rated Voltage for 5 min. Temperature : 20°C
2	Capacitance (µF)		Shall be within tolerance of the nominal value specified.	JIS C 5101-1, 4.7 Frequency : 120 Hz± 20% Voltage : 0.5Vrms+1.5 ~2VDC Temperature : 20°C
3	Dissipation Factor		Shall not exceed the values shown in CATALOG NUMBERS AND RATING OF STANDARD PRODUCTS.	JIS C 5101-1, 4.8 Frequency : 120 Hz± 20% Voltage : 0.5Vrms+1.5 ~2VDC Temperature : 20°C
4	Characteristics at High and Low Temperature			JIS C 5101-1, 4.29
	Step1	Leakage Current Capacitance Dissipation Factor	Shall not exceed the value in No.1. Shall be within the specified tolerance. Shall not exceed the values shown in CATALOG NUMBERS AND RATING OF STANDARD PRODUCTS.	Measuring temperature : 20 ± 2°C
	Step2	Capacitance Change Dissipation Factor	Shall be within ± 10% of the value at Step 1. Shall not exceed the values shown in CATALOG NUMBERS AND RATING OF STANDARD PRODUCTS.	Measuring temperature : -55±3 °C
	Step3	Leakage Current Capacitance Change Dissipation Factor	Shall not exceed the value in No.1. Shall be within ± 2% of the value at Step 1. Shall not exceed the values shown in CATALOG NUMBERS AND RATING OF STANDARD PRODUCTS.	Measuring temperature : 20 ± 2°C
	Step4	Leakage Current Capacitance Change Dissipation Factor	Shall not exceed 0.1 CV or 5 whichever is greater. Shall be within ± 10% of the value at Step 1. Shall not exceed the values shown in CATALOG NUMBERS AND RATING OF STANDARD PRODUCTS.	Measuring temperature : 85±2°C
	Step5	Leakage Current Capacitance Change Dissipation Factor	Shall not exceed 0.125 CV or 6.3 whichever is greater. Shall be within ± 15% of the value at Step 1. Shall not exceed the values shown in CATALOG NUMBERS AND RATING OF STANDARD PRODUCTS.	Measuring temperature : 125±2°C Measuring voltage : Derated voltage at 125°C
	Step6	Leakage Current Capacitance Change Dissipation Factor	Shall not exceed the value in No.1. Shall be within ± 2% of the value at Step 1. Shall not exceed the values shown in CATALOG NUMBERS AND RATING OF STANDARD PRODUCTS.	Measuring temperature : 20 ± 2°C
5	Surge	Leakage Current Capacitance Change Dissipation Factor Appearance	Shall not exceed the value in No.1. Shall be within ± 5% of the value at Step 1. Shall not exceed the value in No.3. There shall be no evidence of mechanical damage.	JIS C 5101-1, 4.26 Test temperature and applied voltage : To each half of specimens • 85 ± 2°C Applied Voltage :DC surge voltage Series protective resistance : 1000 Ω Discharge resistance : 1000 Ω
6	Terminal strength	Tensile strength	No fault such as breakage and loosening terminal	JIS C 5101-1, 4.13.1 Applied force : 5N Duration:10± 1 sec
		Bending strength	No fault such as breakage and loosening terminal	JIS C 5101-1, 4.13.2 Load : 2.5 N Bending sytle:2
7	Vibration	Capacitance Appearance	Initial value to remain steady during measurement. There shall be no evidence of mechanical damage.	JIS C 5101-1, 4.17 Frequency range : 10 ~ 55 Hz Swing width : 1.5 mm Vibration direction : 3 directions with mutually right-angled Duration : 2 hours in each of these mutually perpendicular directions (total 6 hours) Mounting : Solder terminal to the printed board
8	Shock		There shall be no intermittent contact of 0.5 ms or greater, short, or open. Nor shall there be any spark discharge, insulation breakdown, or evidence of mechanical damage.	JIS C 5101-1, 4.19 Peak acceleration :490 m/s <sup>2</sup> Duration : 11 ms Wave form : Half-sine
9	Solderability		Shall be covered to over 3/4 of terminal surface by new soldering.	JIS C 5101-1, 4.15 Solder temperature : 230 ± 5°C Dipping time : 2 ± 0.5 sec Dipping depth : Terminal shall be dipped into melted solder.
10	Resistance to Soldering Heat	Leakage Current	Shall not exceed the value in No.1.	JIS C 5101-1, 4.14 Solder temperature: 260 ± 5°C Dipping time: 10 ± 1 sec Dipping depth : Terminal shall be dipped into melted solder.
		Capacitance Change Dissipation Factor	Shall be within ± 3% of the value at Step 1. Shall not exceed the value in No.3.	
		Appearance	There shall be no evidence of mechanical damage.	

No.	Item		Performance	Test method
11	Rapid Change of Temperature	Leakage Current Capacitance Change Dissipation Factor Appearance	Shall not exceed the value in No.1. Shall be within $\pm 5\%$ of the value at Step 1. Shall not exceed the value in No.3. There shall be no evidence of mechanical damage.	JIS C 5101-1, 4.16 Step 1 : $-55 \pm 3^{\circ}\text{C}$ , 30 $\pm$ 3 min. Step 2 : $25^{+10}_{-5}^{\circ}\text{C}$ , 3 min. max. Step 3 : $125 \pm 2^{\circ}\text{C}$ , 30 $\pm$ 3 min. Step 4 : $25^{+10}_{-5}^{\circ}\text{C}$ , 3 min. max. Number of cycles : 5
12	Damp heat, Steady state	Leakage Current Capacitance Change Dissipation Factor Appearance	Shall not exceed the value in No.1. Shall be within $\pm 5\%$ of the value at Step 1. Shall not exceed the value in No.3. There shall be no evidence of mechanical damage.	JIS C 5101-1, 4.22 Temperature : $40 \pm 2^{\circ}\text{C}$ Moisture : 90 ~ 95%RH Duration : 500 $^{+24}_{-0}$ hrs
13	Endurance	Leakage Current Capacitance Change Dissipation Factor Appearance	Shall not exceed 125% of the value in No.1. Shall be within $\pm 10\%$ of the value at Step 1. Shall not exceed the value in No.3. There shall be no evidence of mechanical damage.	JIS C 5101-1, 4.23 Test temperature and applied voltage : $85 \pm 2^{\circ}\text{C}$ and rated voltage or $125 \pm 3^{\circ}\text{C}$ and $2/3 \times$ rated voltage Duration : 2000 $^{+72}_{-0}$ hrs Power supply impedance : 3 $\Omega$ or less

## FREQUENCY CHARACTERISTICS

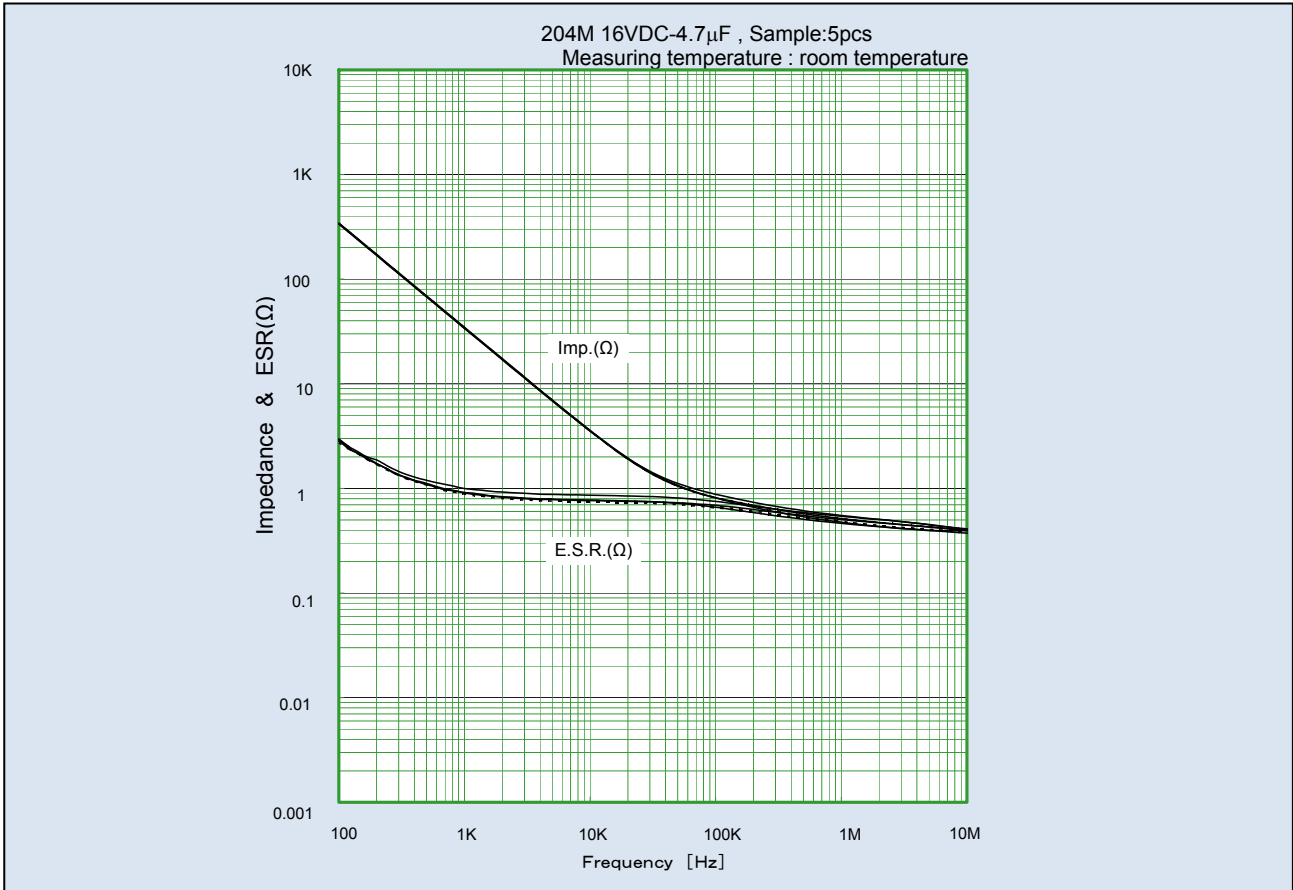

## TEMPERATURE CHARACTERISTICS

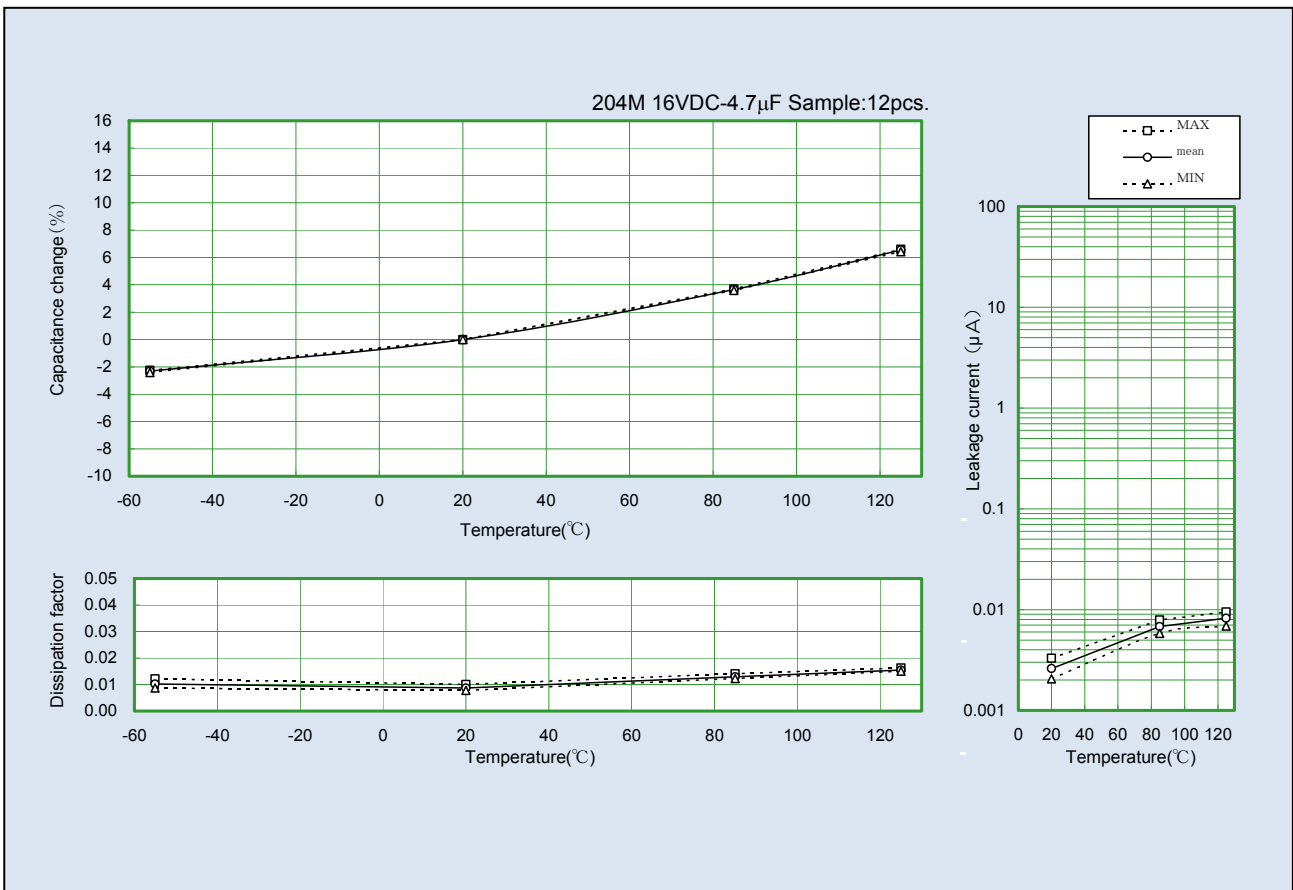

**DAMP HEAT, STEADY STATE 40°C, 95%RH**

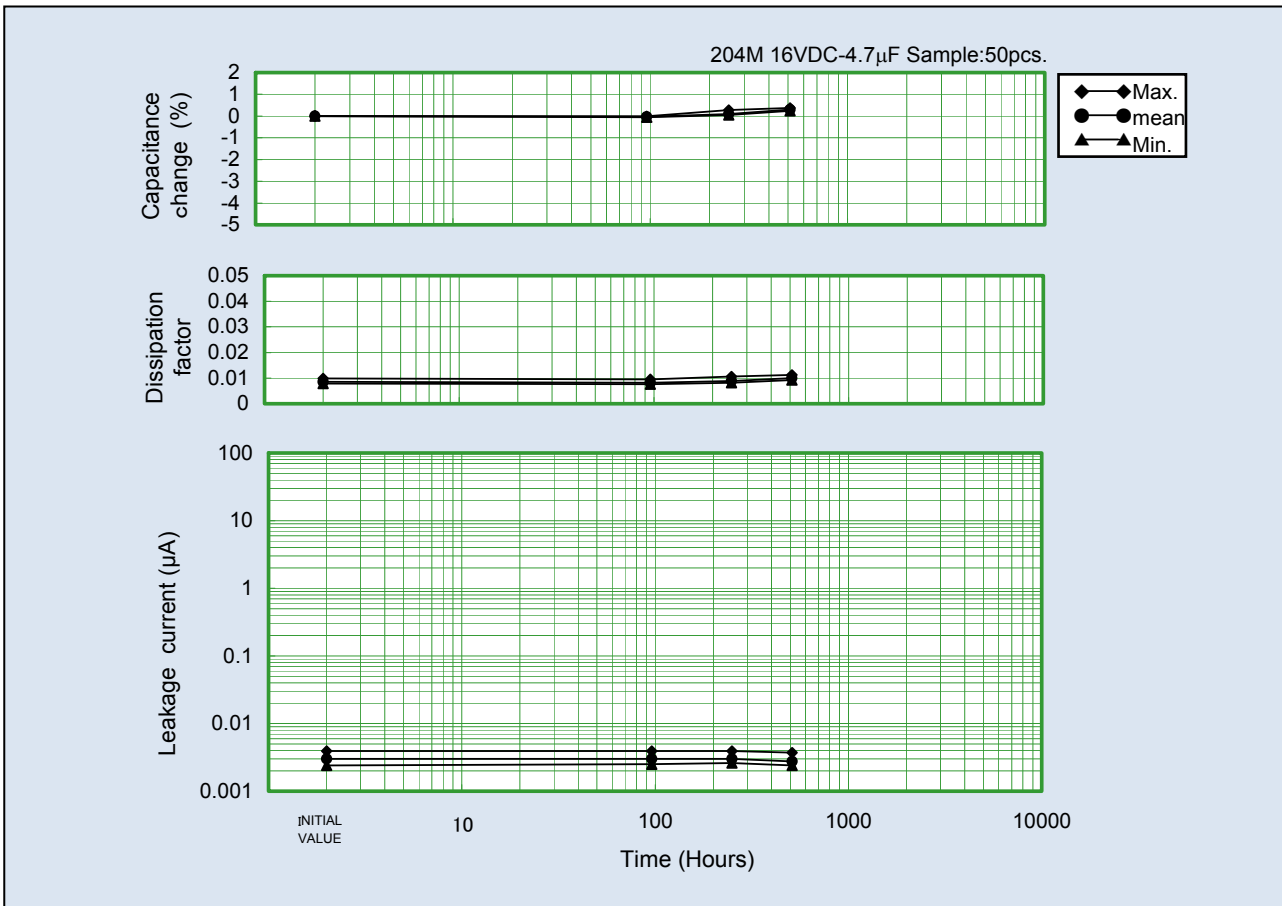

**ENDURANCE 85°C, RATED VOLTAGE**

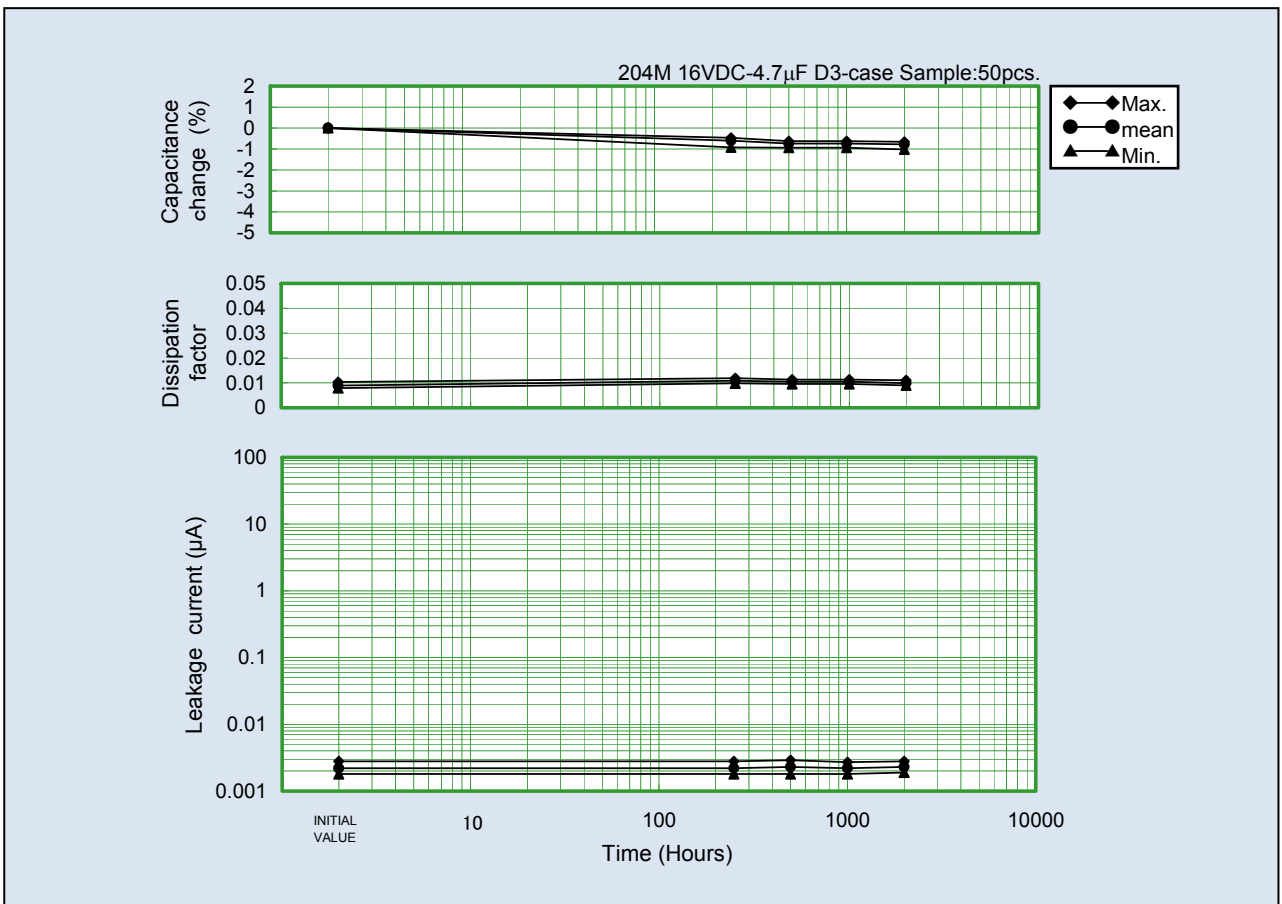



# ⚠ Application Notes for Tantalum Solid Electrolytic Capacitor (Type 204)

## 1. Operating Voltage

Tantalum Solid Electrolytic Capacitor shall be operated at the rated voltage or lower.

**Rated voltage:** The “rated voltage” refers to the maximum DC voltage that is allowed to be continuously applied between the capacitor terminals at the rated temperature.

**Surge voltage:** The “surge voltage” refers to the voltage that is allowed to be instantaneously applied to the capacitor at the rated temperature or the maximum working temperature. The capacitor shall withstand the voltage when a 30-second cycle of application of the voltage through a 1000 Ω series resistance is repeated 1000 times in 6-minute periods.

Rated voltage (VDC)	3.15	6.3	10	16	20	25	35	50
Surge voltage (VDC)	4	8	13	20	25	32	44	63

When designing the circuit, the equipment’s required reliability must be considered and appropriate voltage derating must be performed. Figure 1 shows the recommended voltage derating curve for Tantalum capacitors as described by NASA APPLICATION NOTES.

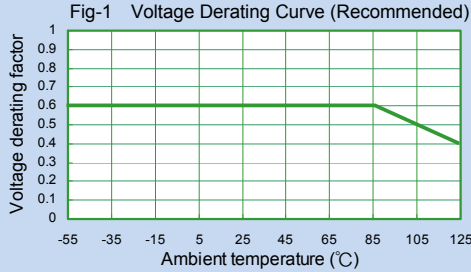

## 2. Application that contain AC Voltage

Special attention to the following 3 items.

- (1) The sum of the DC bias voltage and the positive peak value of the AC voltage should not exceed the rated voltage.
- (2) Reverse voltage should not exceed the allowable values of the negative peak AC voltage.
- (3) Ripple current should not exceed the allowable values.

## 3. Reverse Voltage

Tantalum solid electrolytic capacitor is polarity. Please do not impress reverse voltage. As well, please confirm the potential of the tester beforehand when both ends of the capacitor are checked with the tester etc.

## 4. Permissible Ripple Voltage

Permissible ripple voltage is determined by the heat loss of the element and heat radiation of the lead wire. This is influenced by capacitance, ESR, operating temperature, and frequency or ripple. Please consult Matsuo’s Engineering Bulletin for details on calculating ripple current values.

## 5. Application on low-impedance circuit

The failure rate of low impedance circuit at 0.1Ω/V is about five times greater than that of a 1Ω/V circuit. To curtail this higher failure rate, tantalum capacitors used in low impedance circuits, such as filters for power supplies, particularly switching power supplies, or for noise by-passing, require that operating voltage be derated to less than half of the rated voltage. Actually, less than 1/3 of the rated voltage is recommended.

## 6. Non Polar Application(BACK TO BACK)

Tantalum capacitors can be used as a non-polar unit if two capacitors are connected “BACK-TO-BACK” when reserve voltage is applied at a more than permissible value, or in a purely AC circuit. The two capacitors should both be of the same rated voltage and capacitance tolerance, and they should both be twice the required capacitance value.

**Ripple Voltage:** Permissible Ripple Voltage shall not exceed the value allowed for either C1 or C2 (This will be the same, as the capacitors should be identical.)

**Capacitance:**  $(C1 \times C2) / (C1 + C2)$

**Leakage Current:** If terminal A is (+), the Leakage Current will be equal to C1’s Leakage Current.

If terminal B is (+), the Leakage Current will be equal to C2’s Leakage Current.

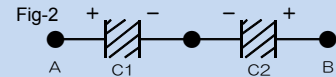

## 7. Soldering

The soldering of Type 204 should be operated per the following recommended conditions.

### (1) Flow Soldering

This type soldering is a way to solder parts from under the glass-epoxy PC board regarding which parts are put into hole of the board.

Figure 3 shows temperature and dipping time of solder Bath.

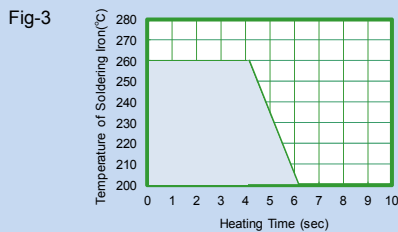

Regarding floor time, if it goes beyond the condition of Figure 3, in order to control temperature raise, spacer should be attached to lead wire by Teflon, which can make products some raise from board. Figure 4 shows tolerance of temperature and dipping time on the case.

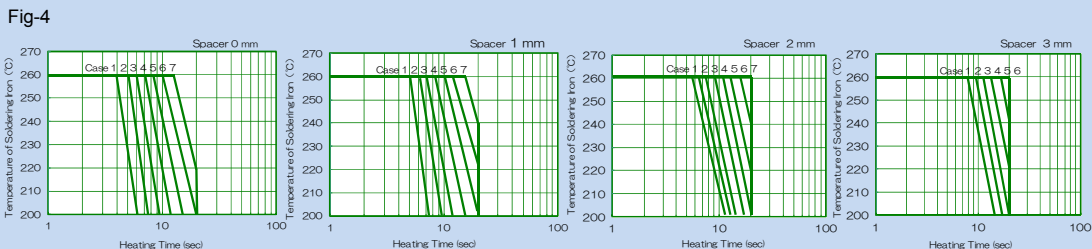

**(2) Soldering with a Soldering Iron**

It is a soldering method that parts are heated up under board by soldering iron after putting parts into through-hole of PC board such as item 7.11. Allowance is shown in Figure 5 regarding temperature and holding time of soldering iron.

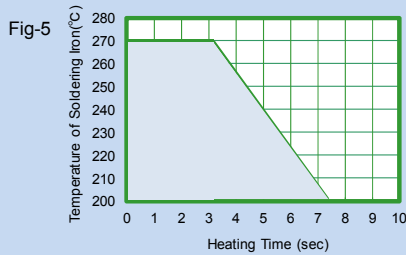

**8.Example of trouble phenomenon happening by excessive heating when soldering**

When mounting, the following breakdown phenomena might be caused when excessive heating that exceeds the above-mentioned tolerance is done. Therefore, please pay attention to the operation.

In a case that solder is used for cathode connection of molding type product, Ag in silver paste could merge into solder if solder in product have melted. That might cause excessive Leakage Current and Short etc. by changing in deterioration in DF and the high frequency impedance or internal stresses in that case.

Mechanical stress according to heat stress and expansion shrinkage or concentrations of internal stress might increase failure rate.

**9.Flux**

Please use flux as much as possible with non-acidity and little content of both chlorine and amine.

**10. Cleaning**

Cleaning by organic solvent may damage capacitor's appearance and performance. However, our capacitors are not effected even when soaked at 20 ~ 30°C 2-propanol for 5 minutes. When introducing new cleaning methods or changing the cleaning term, please consult us.

**11. Protective Resin Coating**

After components are assembled to substrate, a protective resin coating is sometimes applied. As this resin coating cures, it gives mechanical and thermal stress to Tantalum capacitors. This stress can cause damage to the capacitors, which affects their reliability. Before using a resin coating, proper research must be done in regards to the material and process to insure that excessive stress will not be applied to capacitors and other components.

**12. Vibration**

Approximately 300 G shall be applied to a capacitor, when dropped from 1 meter to a concrete floor.

Although capacitors are made to withstand this drop test, stress from shock due to falling or striking does cause damage to the capacitors and increases failure rates. Do not subject capacitors to this type of mechanical stress.

**13. Additional Notes**

- When more than one capacitor is connected in series, a resistor that can distribute the voltage equally to the capacitors shall be connected in parallel.
- The capacitor cases shall not be cut even if the mounting space is insufficient.
- During a customers aging process, voltage should remain under the rated voltage at all times.
- Capacitors should never be touched or manipulated while operating.
- Capacitors are not meant to be dismantled.
- When testing capacitors, please examine the power source before conducting test to insure the tester's polarity and applied voltage.
- In the event of a capacitor burning, smoking, or emitting an offensive smell during operation, please turn the circuit "off" and keep hands and face away from the burning capacitor.
- If a capacitor be electrical shorted, it becomes hot, and the capacitor element may ignite. In this case, the printed board may be burnt out.
- Capacitors should be stored at room temperature under low humidity. Capacitors should never be stored under direct sunlight, and should be stored in an environment containing dust.
- If the capacitors will be operated in a humid environment, they should be sealed with a compound under proper conditions.
- Capacitors should not be stored or operated in environments containing acids, alkalis or active gasses.
- When capacitors are disposed of as "scrap" or waste, they should be treated as Industrial Waste since they contain various metals and polymers.
- Capacitors submitted as samples should not be used for production purposes.

These application notes are prepared based on "Guideline of notabilia for fixed tantalum electrolytic capacitors with solid electrolyte for use in electronic equipment" (EIAJ RCR-2368) issued by Japan Electronics and Information Technology Industries Association (JEITA). For the details of the instructions (explanation, reasons and concrete examples), please refer to this guideline, or consult our Sales Department.



**MATSUO ELECTRIC CO., LTD.**

Please feel free to ask our Sales Department for more information on Tantalum Solid Electrolytic Capacitor .

Overseas Sales Dep. 5-3,3-Chome,Sennari-cho,Toyonaka-shi,Osaka 561-8558,Japan Tel : 06-6332-0883 Fax : 06-6332-0920  
 Head office 5-3,3-Chome,Sennari-cho,Toyonaka-shi,Osaka 561-8558,Japan Tel : 06-6332-0871 Fax : 06-6331-1386  
 URL <http://www.ncc-matsuo.co.jp/>

Specifications on this catalog are subject to change without prior notice. Please inquire of our Sales Department to confirm specifications prior to use.