

## Safe-D Spring Clip

- The spring-tensioned arm drops over to secure cables
- Adjustable according to volume of cables

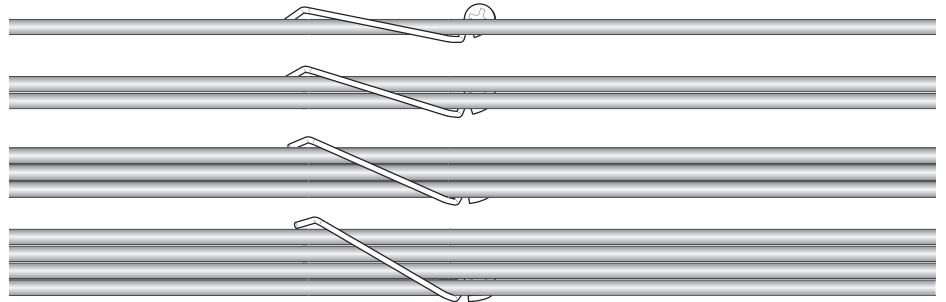

Ideal for direct-to-surface, or can fit micro trunking lengths 10mm - 20mm wide

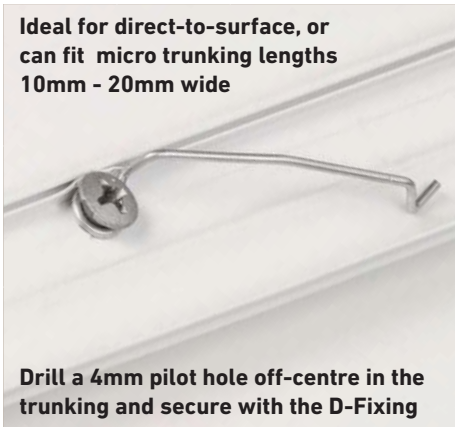

Drill a 4mm pilot hole off-centre in the trunking and secure with the D-Fixing



**Safe-D Spring Clips effectively secure single cables (<7mm o/d), either direct to surface, or in PVC micro trunkings.**

Safe-D Springs use high-temperature non-corrosive sprung steel that is tensioned to provide a strong contact with trunking bases.

In fire conditions, the Springs (when secured with D-Fixings) can hold cables in-situ at 970°C for up to 2 hours. They satisfy all requirements of BS5839 Part 1.

The 50mm long arm is specially kinked to minimise risk of cable bruising or damage to the conductors of soft-skin cables.

- Compliant with BS7671 and BS5839-1 requirements
- Sprung tensioned steel
- >1200°C melting point
- Non-corrosive finish
- Fixing hole is ideal for use with D-Line D-Fixings
- Heightened kink along length minimises risk of cable bruising
- Can be positioned at alternative angles according to application or volume of cables to be secured
- Easy to add or remove cables

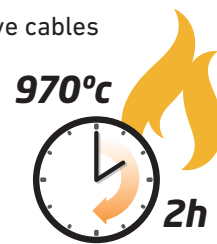
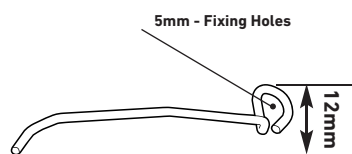
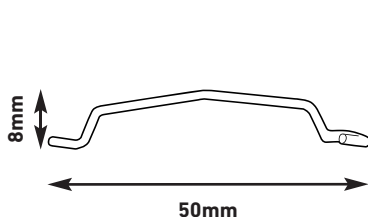

Code	Description
SAFEDSPRING	(L) 50mm x (W) 12mm x (H) 8mm 5mm diameter fixing hole