

Multicleat/Multistrap System

378PF Series



Multicleat and multistrap now use a new and improved locking mechanism making the installation quicker and easier. They also come with a disposable tensioning aid that was introduced in response to customer requests to improve the closure of the cleats and speed of installation. The adapter fits into the open end of the winding pin and is used with a standard 13mm socket wrench to tighten the strap. The same 13mm socket is then used to tighten the locking nut, finishing the installation.

Features and benefits

- Suitable for use with trefoil cable diameters 24 to 145mm.
- Suitable for use with single cable diameters 36 to 120mm.
- Large range take on each size.
- All straps manufactured from non-magnetic 316L Stainless Steel.
- Stainless steel base for harsher environments.
- Single fixing base for applications where flexibility may be required
- Operating temperatures -40°C to +120°C.
- Liners are made from LSOH materials.
- Suitable for single core cables laid in trefoil formation with high fault current capacities.
- Suitable for use with all standard ladder and tray systems.
- Suitable for groups of dissimilar cables.
- Tested in accordance with BS EN 61914 (IEC 61914)

Performance Data

BSEN 61914:2016	Clause	Classification
Type	6.1.3	Composite
Operating Temperature	6.2	-40°C to +120°C
Resistant to electromechanical forces, withstanding one short circuit	6.4.4	Heavy duty strap (3 wraps):61.3kA RMS, 135kA Peak, cleat spacing= 600mm, cable Ø= 38mm
Resistance to Corrosion	6.5.2.2	High, Outdoor - Wet unpolluted conditions
Resistance to Ultraviolet light	6.5.1.2	Pass

* short circuit completed in conjunction with multistrap in a cleat-strap-cleat arrangement



Cable and Cleat Selection						Dimensions			Multistrap		
Design Number		Trefoil Cable Diameter		Single Cable Diameter		B Trefoil	B1 Single	C	Weight (kg)	Standard Strap	Heavy duty Strap
Stainless steel Base (Single Bolt)		mm		mm		mm	mm	mm			
Standard Strap	Heavy Duty Strap	Min	Max	Min	Max	Max	Max				
378PF01	378PF51	24	34	36	65	99	96	76	0.519	377AB01	377AB51
378PF02	378PF52	30	41	60	85	113	116	85	0.538	377AB02	377AB52
378PF03	378PF53	37	47	80	90	121	118	104	0.622	377AB03	377AB53
378PF04	378PF54	43	54	85	110	135	138	110	0.641	377AB04	377AB54
378PF05	378PF55	50	60	-	-	147	-	120	0.701	377AB05	377AB55
378PF06	378PF56	56	67	-	-	161	-	134	0.722	377AB06	377AB56
378PF07	378PF57	63	73	-	-	173	-	146	0.972	377AB07	377AB57
378PF08	378PF58	69	80	-	-	187	-	160	0.992	377AB08	377AB58
378PF09	378PF59	-	-	105	120	-	148	120	0.66	377AB09	377AB59

* Technical Information subject to change without notice

Important note: To ensure adequate restraint, Multistrap MUST be used at the mid-point between cleats on all horizontal and vertical straight runs.

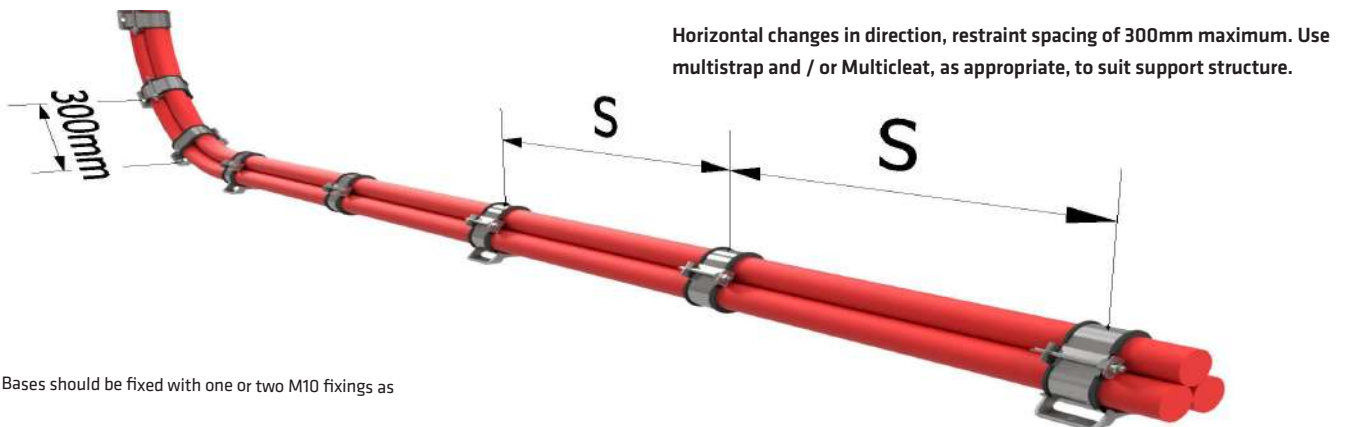

Note: Bases should be fixed with one or two M10 fixings as

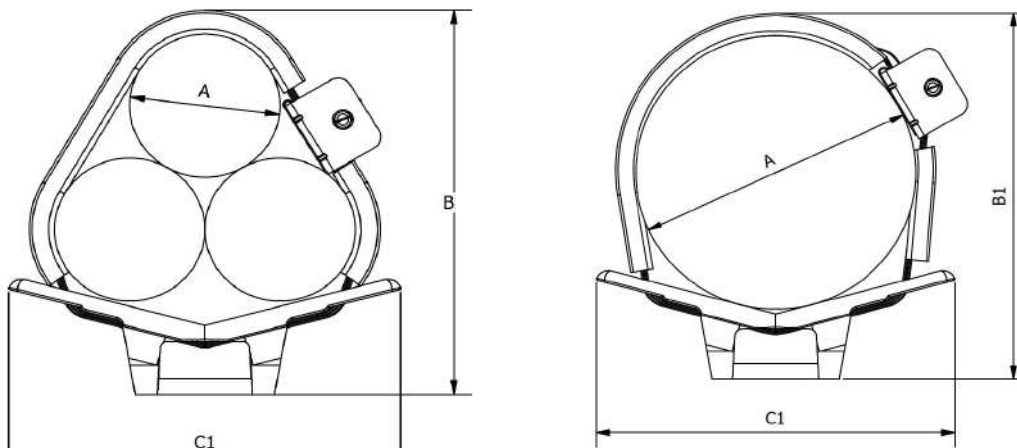

Prysmian Cables & Systems Limited,
Oak Road, Wrexham Industrial Estate, Wrexham, LL13 9PH, UK

Commercial Enquiries,
Sales Office Tel: 0845 767 8345,
International Sales Office Tel: +44 2380 295481