

CEETAP Connectors



CEETAP Connectors (6-240mm)

Description

- > CEETAP connectors offer a versatile means of tapping onto annealed stranded or flexible copper conductors including copper busbar and earthing systems.
- > The CEETAP is manufactured from heavy wall copper extrusion and provides excellent continuity and reliability.
- > Designed to accept a range of conductors the CEETAP is applied over the uncut main. It is easy to install and uses standard tooling.
- > Copper CEETAP connectors are also used on overhead line electricity distribution systems. The copper conductors on these systems are hard drawn and have different ratings to annealed connectors.
- > Tested and approved to BS3288 & BS4579

Material

- > High conductivity copper

CEETAP Connectors

CEETAP Connectors (6-240mm)

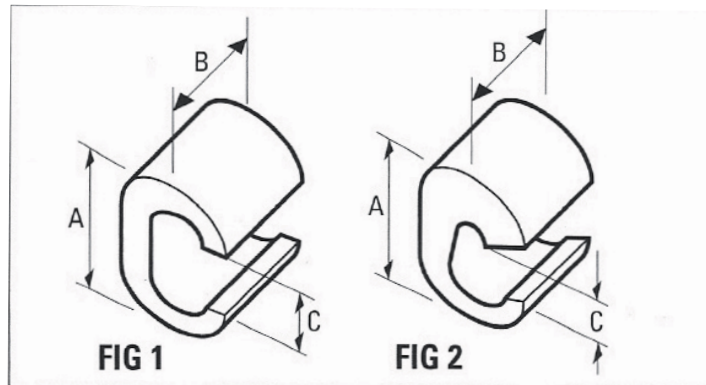

Connector Details

Annealed Copper Conductor Size (mm ²)		Reference Number	CEETAP Fig Number	Dimensions			Installation Tooling	
Main	Tap			A	B	C	G10/E10HB Head Die Set	No. of Crimps
6	6	TC2C	1	11.8	13.5	4.4	U162	1
10	2.5 to 6							
10	10	TC3C	2	18.6	16.5	6.6	U-BG	1
16	2.5 to 10							
16	16	TC4C	2	19.4	17.7	6.7	U-BG	1
25	4 to 10							
25	16	TC5C	1	20.6	17.8	8.7	U-BG	1
35	4							
25	25	TC6C	2	24.9	20.7	8.5	U-C	1
35	6 to 25							
35	35	TC7C	1	26.5	20.7	11.5	U-C	1
50	35 to 50							
70	16	TC10C	2	41.9	27.7	14.5	U-F	3
70 to 95	16 to 35							
70 to 95	50 to 70	TC11C	2	40.9	28.0	14.4	U-F	3
95	95							
120	95 to 120	TC14C	1	44.3	46.8	15.9	U708	6
150	35 to 150							
185 to 240	50 to 95	TC16C	2	51.0	56.0	21.0	P717*	2
185 to 240	120 to 240							
185 to 240	120 to 240	TC17C	1	57.8	56.0	21.0	P717*	3

* For use with G14H head only