

# Two Bolt Cleat (Aluminium)

## 370 Series

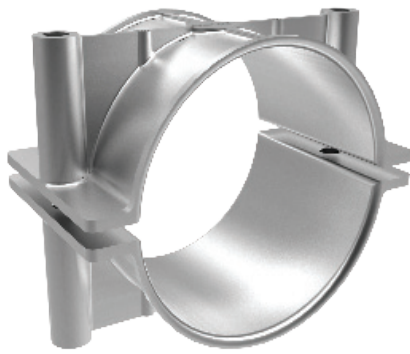

**The aluminium two bolt cleat is an LUL approved cable cleat which can be applied to all types of cable routes.**

### Features and Benefits

- Suitable for use with cable diameters 51 to 159mm.
- Manufactured from aluminium alloy.
- Two-piece, two fixing design.
- Can be double stacked on common fixings.
- Operating temperature -60°C to +105°C.
- Suitable for LV & HV cables.
- Can be used for all types of cable routes.
- Plain finish - for normal industrial areas or outdoor unpolluted areas.
- Epoxy coated versions available for harsh environments.
- Optional rubber liners available.
- Tested in accordance with BS EN 50368.
- LUL APR Product ID 1963

### Performance Data

Test Standard	EN 50368:2003
Type	6.1.1 Metallic
Impact Resistance	6.2.5 V. Heavy
Lateral Load	18.1 kN
Axial Load	11.4 -> 13.8kN
Needle Flame	>120 secs

\* Technical Information subject to change without notice



## Technical Data

Cable and Cleat Selection				Cleat Details					
Design Number		Cable Diameter		Dimensions (mm)				Stud Size	Weight (g)
Standard	Epoxy Coated	A (mm)		B (mm)	C	D	E		
		Min	Max	Max					
370BA10	370BB10	51	57	70	98	49	76	M10	230
370BA11	370BB11	57	64	76	98	49	76	M10	240
370BA12	370BB12	64	70	82	135	64	114	M10	384
370BA13	370BB13	70	76	88	135	64	114	M10	384
370BA14	370BB14	76	83	96	140	64	114	M12	420
370BA15	370BB15	83	89	101	140	64	114	M12	490
370BA16	370BB16	89	95	108	152	76	126	M12	442
370BA17	370BB17	95	101	114	152	76	126	M12	442
370BA18	370BB18	101	108	120	165	76	140	M12	650
370BA19	370BB19	108	114	126	165	76	140	M12	650
370BA30	370BB30	115	121	133	175	100	150	M12	734
370BA31	370BB31	121	127	139	175	120	150	M12	720
370BA32	370BB32	127	133	145	200	120	175	M12	970
370BA33	370BB33	133	140	152	200	120	175	M12	956
370BA34	370BB34	140	146	158	200	120	175	M12	935
370BA35	370BB35	146	152	164	210	120	185	M12	893
370BA36	370BB36	152	159	172	215	150	190	M12	1325

### Method of Fixing

In all applications the cleat should be mounted on suitable fixings, see table for appropriate size.  
When mounting directly on channel, adapter plate 380AG02 should be used.

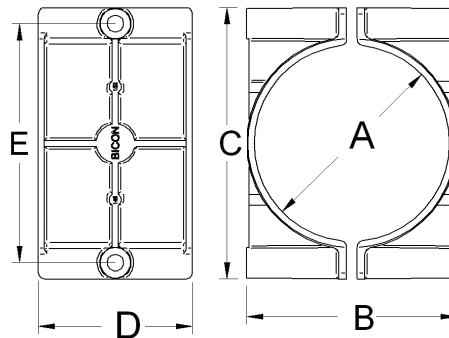

**Prysmian Cables & Systems Limited,**  
Oak Road, Wrexham Industrial Estate, Wrexham, LL13 9PH, UK

**Commercial Enquiries,**  
Sales Office Tel: 0845 767 8345,  
International Sales Office Tel: +44 2380 295481

[www.biconcomponents.co.uk](http://www.biconcomponents.co.uk)

