

# Cable Connectors



## Un-insulated Copper Tube Terminals

### Application

#### 1-800mm<sup>2</sup> Un-insulated Copper Tube Terminals Splices (Prefix BT\_)

### Description

- > One range of connectors, suitable for voltages up to 6.6kV for use on copper and tin plated copper conductors with stranded or flexible annealed construction.
- > The BT range of connectors are manufactured from high purity oxygen free copper which are then electro tin plated to prevent corrosion; this makes them suitable for operating temperatures up to 150°C.
- > Each terminal includes a sight hole for visual inspection of the conductor inserted.
- > The terminals can be installed with indent or hexagonal compression systems up to 400mm<sup>2</sup> on stranded conductor. Above 400mm<sup>2</sup> or on flexible conductors indent compression is required.
- > Each die set imprints the size of stranded conductor onto the connector to show that the correct tooling has been applied.
- > A wide selection of single stud holes and straight splices are provided and other configurations; two hole and four hole variants are available on request. All connectors are installed with a single crimp except where otherwise stated.
- > Flexible conductors normally have a larger overall diameter than their stranded equivalents – meaning that flexible conductors often won't fit into the correct size tube terminals. In this case we recommend using the next size up in the range combined with the Indent crimp dies.
- > Tube terminals and splices and the associated Crimp Die reference tables can be seen on the following pages.

### Approvals

Tested and approved to :

- > BS EN 61238 (2003) class A (including short circuit)
- > BS 4579 Part 1
- > BS 7609 (2009) Code of practice for installation un-insulated connectors

# Uninsulated Tube Terminals

## Cable size and Connector Details - Tube Terminals

Conductor Size mm <sup>2</sup>	Stud Size (mm)	Catalogue Number	C (mm)	L (mm)	Z (mm)	N (mm)
1	3.5	BT1C35	6.1	16.2	6.1	3.8
1.5-2.5	4	BT2C4	8.0	19.5	6.1	4.3
1.5-2.5	6	BT2C6	8.0	19.5	6.1	4.3
1.5-2.5	8	BT2C8	11.1	24.0	8.1	7.1
4.0-6.0	3.5/4	BT6C354	7.8	25.4	6.1	3.7
4.0-6.0	5	BT6C5	9.9	25.4	5.0	4.5
4.0-6.0	6	BT6C6	12.3	26.9	6.3	5.7
4.0-6.0	8	BT6C8	13.9	31.3	8.5	7.7
4.0-6.0	10	BT6C10	14.7	35.3	10.5	9.5
10	6	BT10C6	11.6	27.4	6.3	5.7
10	8	BT10C8	14.8	34.4	8.5	7.7
10	10	BT10C10	14.8	38.4	10.5	9.5
16	6	BT16C6	13.2	32.0	6.3	5.7
16	8	BT16C8	15.6	36.4	8.5	7.7
16	10	BT16C10	15.6	40.4	10.5	9.5
16	12	BT16C12	21.6	43.4	12.0	10.8
25	6	BT25C6	14.4	32.6	6.3	5.7
25	8	BT25C8	16.4	37.0	8.5	7.7
25	10	BT25C10	16.4	41.0	10.5	9.5
25	12	BT25C12	19.7	44.0	12.0	10.8
35	10	BT35C10	17.6	44.6	10.5	9.5
35	12	BT35C12	20.0	47.6	12.0	10.8
50	6	BT50C6	20.0	37.4	6.3	5.7
50	8	BT50C8	20.0	41.8	8.5	7.7
50	10	BT50C10	20.0	45.8	10.5	9.5
50	12	BT50C12	22.3	48.8	12.0	10.8
70	8	BT70C8	24.3	49.9	8.5	7.7
70	10	BT70C10	24.3	53.9	10.5	9.5
70	12	BT70C12	24.3	56.9	12.0	10.8
95	8	BT95C8	26.8	51.8	8.5	7.7
95	10	BT95C10	26.8	55.8	10.5	9.5
95	12	BT95C12	26.8	58.8	12.0	10.8
120	10	BT120C10	29.5	56.7	10.5	9.5
120	12	BT120C12	29.5	59.7	12.0	10.8
120	16	BT120C16	29.5	65.7	15.0	13.5
150	10	BT150C10	33.0	65.2	10.5	9.5
150	12	BT150C12	33.0	68.2	12.0	10.8
150	16	BT150C16	33.0	74.2	15.0	13.5
185	10	BT185C10	36.1	72.7	10.5	9.5
185	12	BT185C12	36.1	75.7	12.0	10.8
185	16	BT185C16	36.1	81.7	15.0	13.5
240	10	BT240C10	41.9	80.5	10.5	9.5
240	12	BT240C12	41.9	83.5	12.0	10.8
240	16	BT240C16	41.9	89.5	15.0	13.5
240	20	BT240C20	41.9	96.5	18.5	16.7
300	12	BT300C12	46.0	88.0	12.0	10.8
300	16	BT300C16	46.0	94.0	15.0	13.5
300	20	BT300C20	46.0	101.0	18.5	16.7
400	16	BT400C16	51.6	99.0	15.0	13.5
400	20	BT400C20	51.6	106.0	18.5	16.7
500	16	BT500C16	56.2	101.0	15.0	13.5
630	16	BT630C16	65.0	108.5	15.0	13.5
630	20	BT630C20	65.0	115.5	18.5	16.7
800	20	BT800C20	70.0	127.4	18.5	16.7

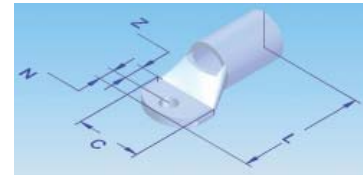

# Uninsulated Tube Terminals

## Cable Size and Connector Details – Butt Splices

Conductor Size mm <sup>2</sup>	Catalogue Number	L (mm)	D (mm)
1.5-2.5	BT2CS	16.1	4.0
4.0-6.0	BT6CS	19.3	5.4
10	BT10CS	26.2	6.9
16	BT16CS	29.4	7.9
25	BT25CS	29.4	9.5
35	BT35CS	36.5	11.7
50	BT50CS	36.5	13.0
70	BT70CS	46.0	16.1
95	BT95CS	46.8	17.7
120	BT120CS	50.0	19.6
150	BT150CS	74.0	22.5
185	BT185CS	63.5	24.2
240	BT240CS	73.0	28.6
300	BT300CS	98.0	31.1
400	BT400CS	85.7	35.0
500	BT500CS	98.0	38.1
630	BT630CS	104.8	44.1
800	BT800CS	114.3	46.7

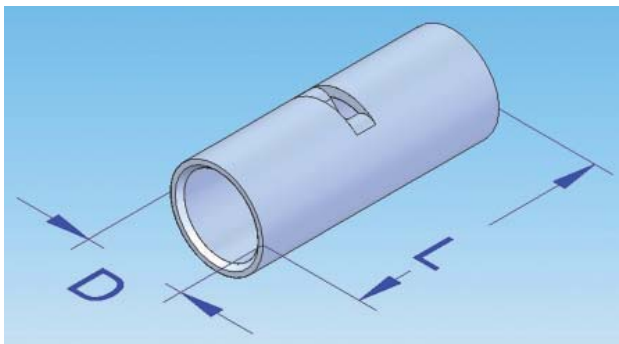

Design for sizes up to 120mm<sup>2</sup>

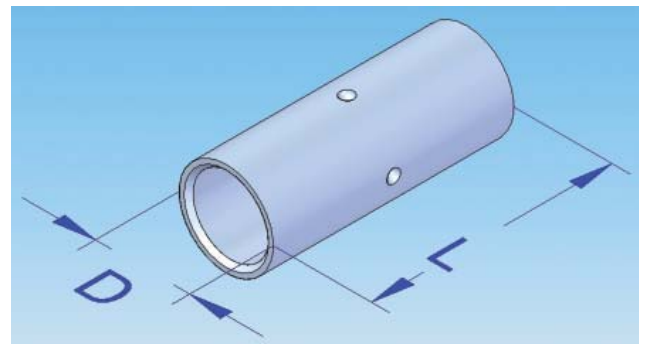

Design for sizes 150mm<sup>2</sup> to 800mm<sup>2</sup>

## Crimp Die Reference Table

Conductor Connector		'U' Dies G10ts / E10-2000 10 ton dies				'P' Dies G14H 14 ton dies				'E18' Dies E18HB 18 ton dies				E22H 'ED' Dies 22 ton dies					
		Size	Type	Connector	Twin / Hex	Nest	Indent	Twin / Hex	Nest	Indent	Adaptor	Twin / Hex	Nest	Indent	Adaptor	Twin / Hex	Nest	Indent	Adaptor
10	STR	BT10	U10CHEX (1)	UNX10C	UP10-25C														
10	FLEX	BT16	not available	UNX16C	UP10-25C														
16	STR	BT16	U16CHEX (1)	UNX16C	UP10-25C														
16	FLEX	BT25	not available	UNX25C	UP10-25C														
25	STR	BT25	U25CHEX (1)	UNX25C	UP10-25C														
25	FLEX	BT35	not available	UNX35C	UP35-50C														
35	STR	BT35	U35CHEX (1)	UNX35C	UP35-50C														
35	FLEX	BT50	not available	UNX50C	UP35-50C														
50	STR	BT50	U50CHEX (1)	UNX50C	UP35-50C														
50	FLEX	BT70	not available	UNX70C	UP50-240CW														
70	STR	BT70	U70CHEX (1)	UNX70C	UP70-300C														
70	FLEX	BT95	not available	UNX95C	UP50-240CW														
95	STR	BT95	U95CHEX (1)	UNX95C	UP70-300C														
95	FLEX	BT120	not available	UNX120C	UP50-240CW														
120	STR	BT120	U120CHEX (1)	UNX120C	UP70-300C														
120	FLEX	BT150	not available	UNX150C	UP50-240CW														
150	STR	BT150	U150CHEX (2)	UNX150C	UP70-300C														
150	FLEX	BT185	not available	UNX185C	UP50-240CW														
185	STR	BT185	U185CHEX (2)	UNX185C	UP70-300C														
185	FLEX	BT240	not available	UNX240C	UP50-240CW														
240	STR	BT240	U240CHEX (2)	UNX240C	UP70-300C														
240	FLEX	BT300	not available	UNX300C	UP50-240CW														
300	STR	BT300	U300CHEX (3)	UNX300C	UP70-300C														
300	FLEX	BT400	not available	not available	not available														
400	STR	BT400	U400CHEX (3)	not available	not available														
500	STR	BT500																	
630	STR	BT630																	
800	STR	BT800																	
1000	STR	BT1000																	

Note: figures in brackets indicate the number of crimps required along the connector barrel