

A2 LSOH COMPRESSION GLAND

for Unarmoured Fire Rated Cable



Features and Benefits

- For indoor and outdoor use.
- Seals the cable sheath to IP65/66/68.
- Silicon seals are fire retardant, low smoke zero halogen and are suitable for extreme temperatures.
- Precision manufactured from high quality brass (nickel plated) available in aluminium or stainless steel 316/316L on request.
- Complete with heavy duty locknut.
- Complete with fire retardant, low smoke zero halogen, extreme temperature thread sealing gasket.

Technical Data

Type:	A2 LSOH
Gland Material:	Brass (Nickel Plated) BS 2874, EN 12164, Aluminium ASTM BS221, Stainless Steel 316/316L
Seal Material:	LSOH Silicon
Cable Type:	Unarmoured Fire Rated
Sealing Area:	Outer Sheath
Optional Accessories:	Adaptor, Reducer, Earth Tag, Locknut, Serrated Washer and Shroud

Standards and Certifications

Mechanical Properties:	Impact Category 8 Anchorage Type B
Continuous Operating Temp:	-65°C to +175°C
Conformance:	Standard: Certificate:
Design Standards	BS 6121:Part 1 CML 14CA364 EN 50262 CML 14CA364 IEC/BS EN 62444 CML 14CA364 SANS 62444 MASC 11-303 SANS 1213 MASC 18-2047, SANS 2109/4596 IP66/68 100m - Parallel IEC 60529 CML 15Y728, MASC 11-263 IP65 - Tapered IEC 60529
Marine ABS	IEC 62444 ABS 20-SG1952694-PDA
DNV-GL	IEC 60529, BS 6121, IEC 62444 DNV-GL TAE000000Z
Halogen Free	IEC 60754-2 TDWR 14-04-13
Flame Retardant	ASTM D 2863-09, ISO 4589-2 TDWR 14-04-13
Low Smoke	EN45545-2 CSIR 24580f
London Underground Approval	BS EN 62444 LU 3043

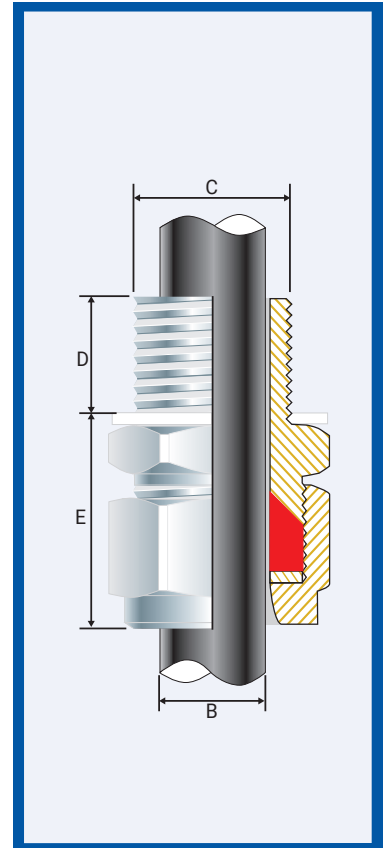

Installation Standards

- AS/NZS 3000
- BS 6121-5
- BS 7671
- BS 7430
- IEC 60364-5-54
- SANS 0142

Product Code	Gland Size Reference	Metric Entry Thread		NPT Entry Thread		Cable Detail		Maximum Length 'E'	Hexagonal Detail		Installation Torque Value Nm
		'C'	Min 'D'	'C'	Min 'D'	Min 'B'	Max 'B'		Max 'Flats'	Max 'Crns'	
055200-16S	00-16S	M16x1.5	10	-	-	1.0	6.0	20.0	♦ 18.0	♦ 20.0	20.0
055200-16	00-16ss	M16x1.5	10	-	-	3.0	8.5	20.0	♦ 24.0	♦ 27.0	32.5
055200	00-20ss	M20x1.5	10	1/2/3/4	15	3.0	8.5	20.0	♦ 24.0	♦ 27.0	32.5
0552-0	0-20s	M20x1.5	10	1/2/3/4	15	7.0	11.5	20.0	♦ 24.0	♦ 27.0	32.5
055201	1-20	M20x1.5	10	1/2/3/4	15	11.0	15.0	24.0	♦ 27.0	♦ 30.0	32.5
055222	2s-25s	M25x1.5	10	3/4/1	15/19	11.5	17.5	25.0	♦ 35.0	♦ 39.0	47.5
055202	2-25	M25x1.5	10	3/4/1	15/19	15.0	20.0	25.0	♦ 35.0	♦ 39.0	47.5
055233	3s-32s	M32x1.5	10	1/1 1/4	19	16.0	22.0	30.0	♦ 42.0	♦ 47.0	55.0
055203	3-32	M32x1.5	10	1/1 1/4	19	20.0	26.5	30.0	♦ 42.0	♦ 47.0	55.0
055244	4s-40s	M40x1.5	15	1 1/4/1 1/2	19/21	22.0	31.5	30.0	♦ 52.0	♦ 59.0	65.0
055204	4-40	M40x1.5	15	1 1/4/1 1/2	19/21	26.0	34.0	30.0	♦ 52.0	♦ 59.0	65.0
055255	5s-50s	M50x1.5	15	1 1/2	21	29.0	38.0	42.0	♦ 65.0	♦ 73.0	82.5
055205	5-50	M50x1.5	15	2	21	34.0	44.5	42.0	♦ 65.0	♦ 73.0	82.5
055266	6s-63s	M63x1.5	15	2	21	38.0	50.0	48.0	♦ 80.0	♦ 90.0	97.5
055206	6-63	M63x1.5	15	2 1/2	30	44.5	56.5	48.0	♦ 80.0	♦ 90.0	97.5
055277	7s-75s	M75x1.5	15	2 1/2	30	50.0	62.0	50.0	♦ 96.0	♦ 108.0	115.0
055207	7-75	M75x1.5	15	3	32	56.0	67.5	50.0	♦ 96.0	♦ 108.0	115.0
055288	8s-80s	M80x2.0	20	3	32	54.0	69.0	55.0	♦ 96.0	♦ 108.0	120.0
055208	8-80	M80x2.0	20	3	32	65.0	74.0	55.0	♦ 96.0	♦ 108.0	120.0
055299	9s-90s	M90x2.0	20	3	32	60.0	75.0	60.0	♦ 111.0	♦ 125.0	120.0
055209	9-90	M90x2.0	20	3 1/2	33	73.0	81.5	60.0	♦ 111.0	♦ 125.0	120.0
055210	10-100	M100x2.0	20	3 1/2/4	33/34	81.0	91.0	74.0	-	-	120.0
055211	11-110	M110x2.0	20	4	34	91.0	101.0	92.5	-	-	175.0
055212	12-120	M120x2.0	20	-	-	101.0	109.0	92.5	-	-	175.0
055213	13-130	M130x2.0	20	-	-	109.0	119.0	92.5	-	-	175.0

All dimensions except NPT are in mm.

• When manufactured in Aluminium, Hex will be 27 Across Flats and 30 Across Corners.

CCG reserves the right to make alterations to the technical data, dimensions, designs and products available without notice. The illustrations cannot be considered binding. Please contact CCG for assistance.

A2LSOH-LS200820E

All Enquiries: tel: +44 (0)1744 762 929 | email: sales@etechncomponents.com | web: www.etechncomponents.com

2020 © CCG CABLE TERMINATIONS (PTY) LTD

A2 LSOH COMPRESSION GLAND

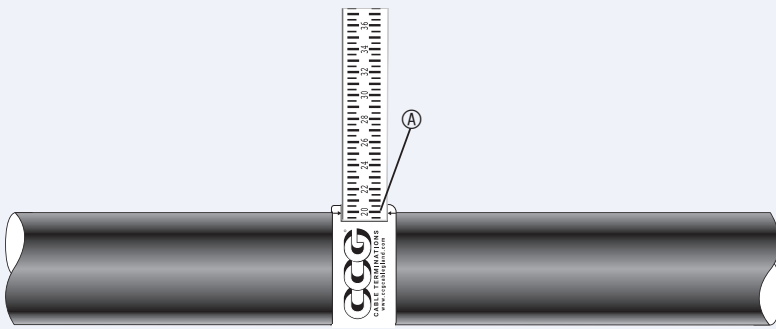

1. For accurate sizing, use a CCG Dimension Tape (A) on the outer cable sheath.

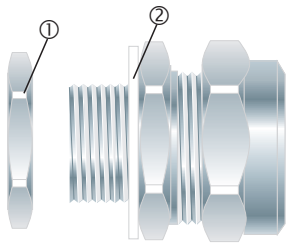

2. To maintain IP66/68 ensure the gasket (2) is in place. Remove locknut (1).

Alternative installation through an unthreaded entry.

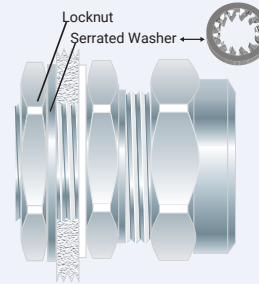

If the apparatus is untapped use a locknut.

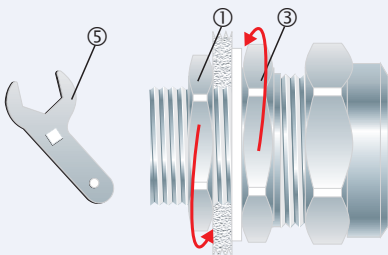

3. Screw the inner (3) into the apparatus and tighten the inner (3) to the installation torque using a CCG Spanner (5). Tighten the locknut (1).

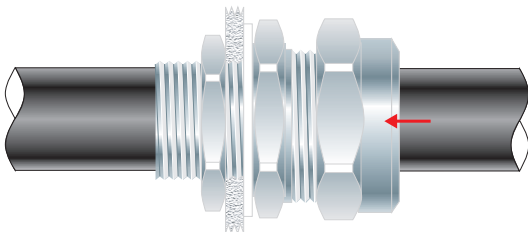

4. Pass the cable end through the gland assembly.

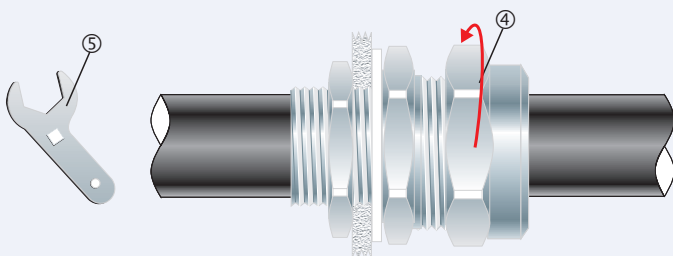

5. Tighten the outer (4) to the installation torque using a CCG Spanner (5).