

# JTS1...W

## SINGLE CORE HEATSHRINKABLE STRAIGHT THROUGH JOINT

INSTALLATION INSTRUCTION IM20761 - ed. 15/01/2020

TYPE OF CABLE:	Solid insulation (XLPE-HEPR)
SECTION:	up to 630 mm <sup>2</sup> Cu/Al
TYPE OF SCREEN:	Copper wires
VOLTAGE:	U <sub>max</sub> 24kV



● 1.1

Straighten and set cables at the joint position. Determine the centre of the joint and cut one cable to length. Cut the other cable with a 250 mm overlap. Clean both outer sheaths for 1 m.

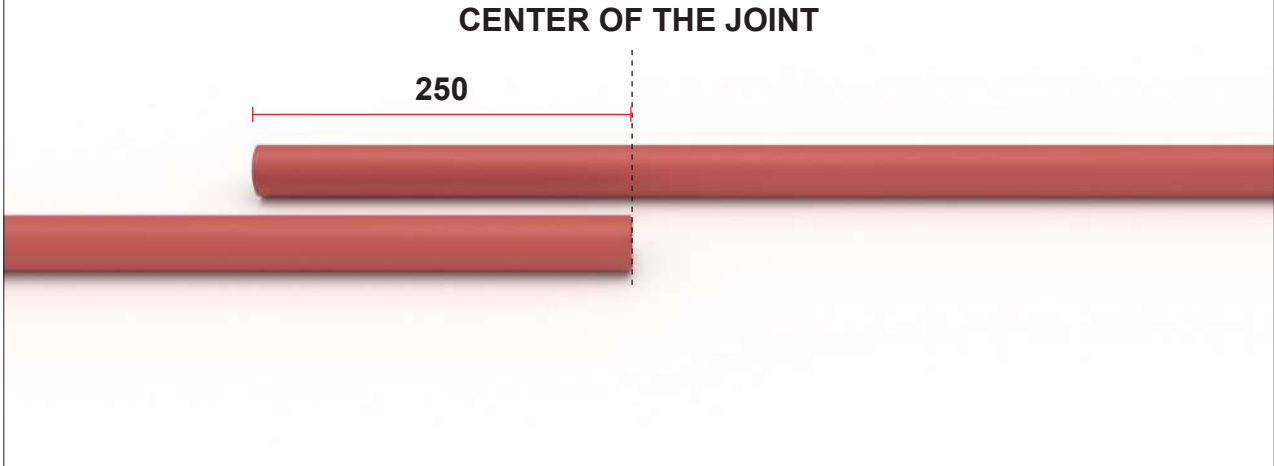



● 2.1

Remove the outer sheath for a distance “Y” as listed in the table, for one cable and “Y” plus 250 mm for the other cable.

● 2.2

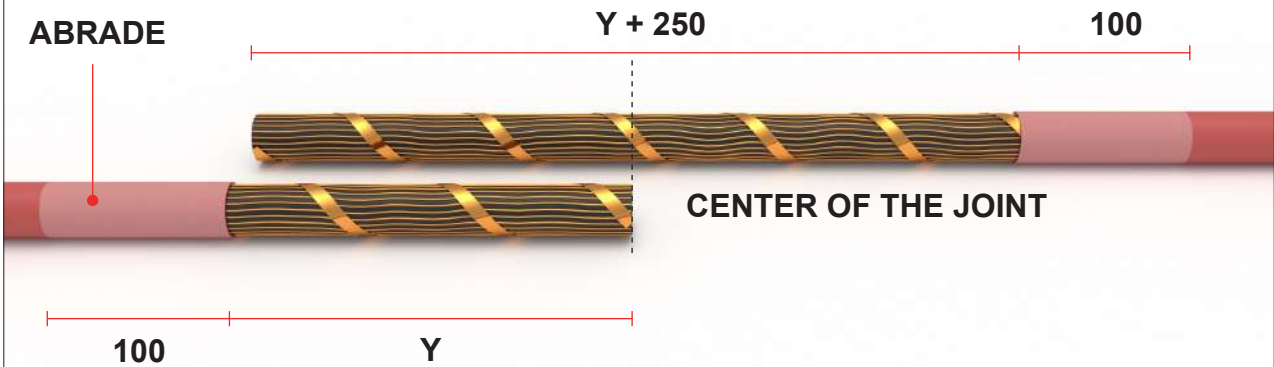
Abrade the outer sheath on both cables for a distance of 100 mm. Clean the abraded area.



	Length of "Triple wall" tube	<b>Y</b>
	300 mm	170 mm
350 mm	190 mm	
400 mm	220 mm	
500 mm	270 mm	
600 mm	320 mm	

● **2.3**

Fold back the screen wires and bind temporarily with PVC tape. DO NOT CUT THE SCREEN WIRES.

● **2.4**

Cut the cable with the 250 mm overlap to the correct distance “Y” as listed in the table.

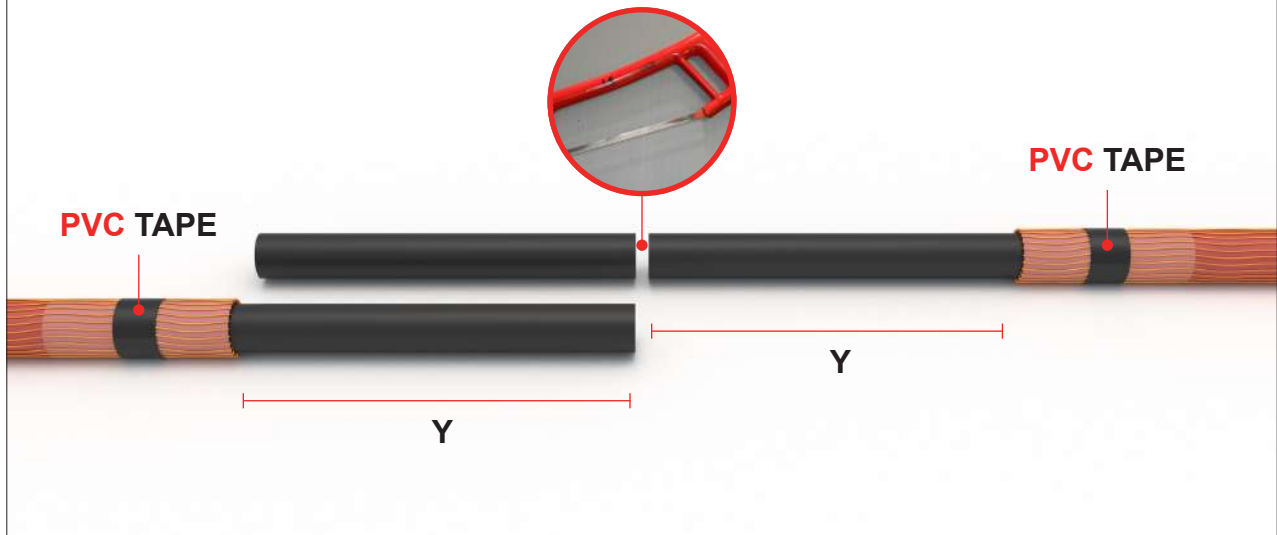

● **2.5**

Remove the semiconductive layer to a distance of 50 mm from the sheath cut. Take care not to damage the insulation.

● **2.6**

Bare the conductor for a length of inside depth of the connector for mechanical types or, in case of compression ones, for a length of inside depth of the connector + 5 mm. Clean and degrease the conductor.

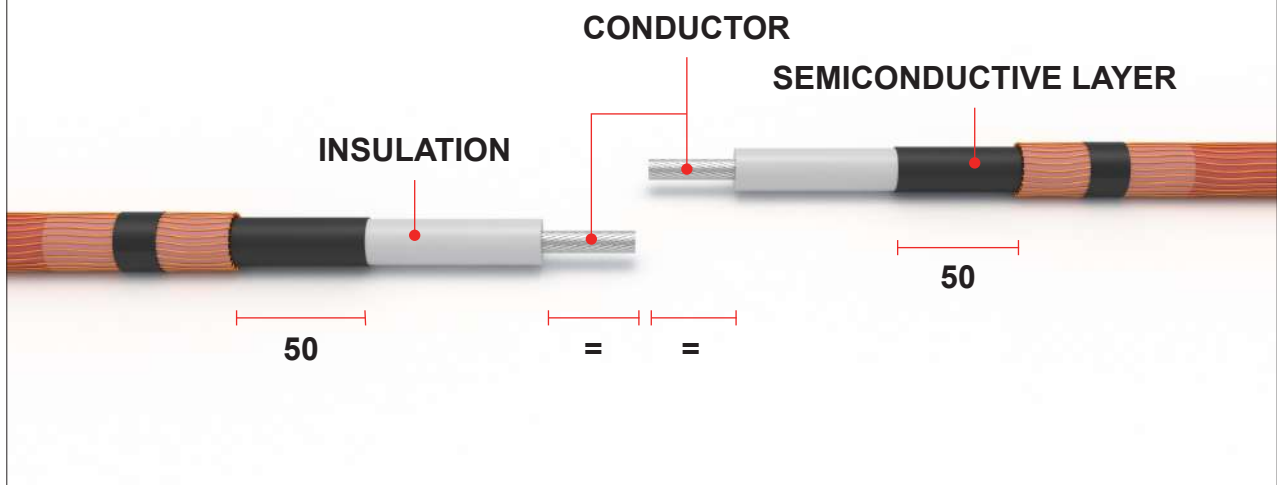

## 2.7

As a protection, wrap few turns of adhesive tape around the conductor end. Slide all the heat shrinkable tubes onto the cable on one side of the joint.

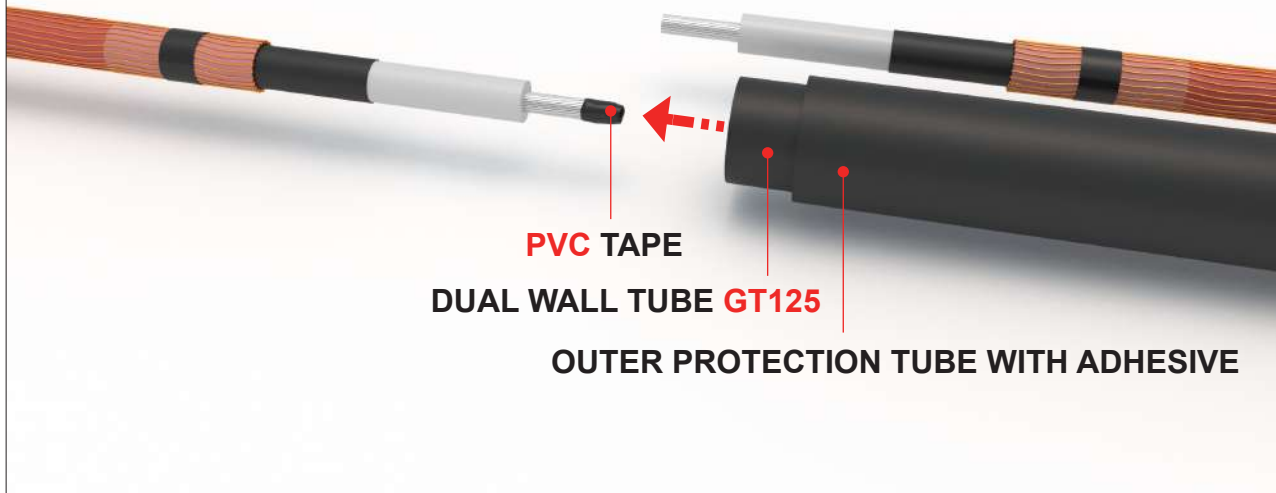

## 3.1

Install the connector onto the cable cores as per the manufacturer's instructions. If using hexagonal compression links ensure that any sharp edges and flashing are removed from the connector with a file or abrasive cloth. If using mechanical connectors make sure any indents left after shearing the bolts are filled with "CLAY" mastic mas.



### 3.2

Wrap the mastic patch around the connector area, centering the patch over the connector with equal distance at both sides. Do not squeeze the extremities.

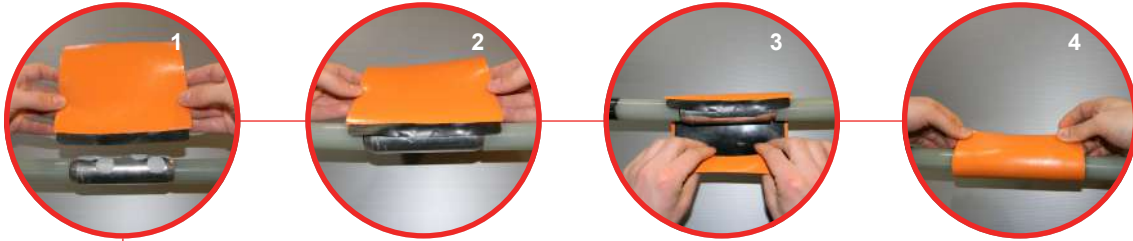

MASTIC PATCH

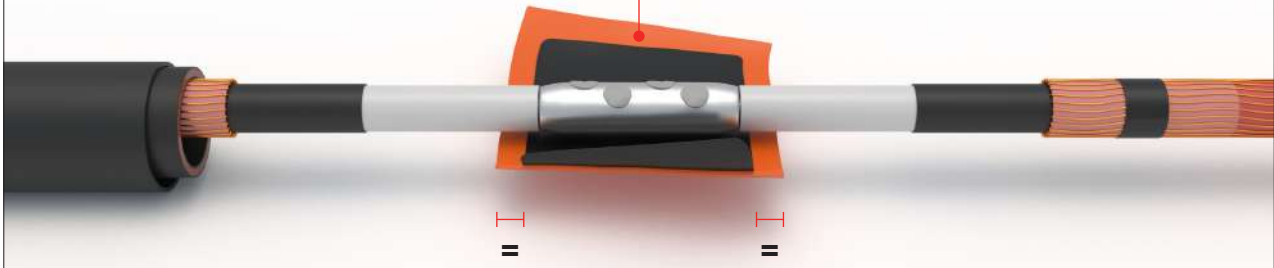

### 3.3

Apply a layer of stress relief mastic "OM" overlapping the semiconductive layer and the insulation of the cable (short mastic strip).

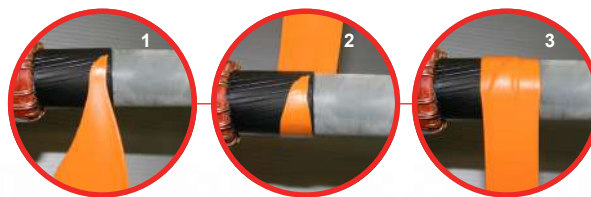

MASTIC OM SHORT STRIP

MASTIC OM SHORT STRIP



● 3.4

Position the triple wall tube "GT125" in the centre of the joint, pre-heat the tube for a minute and start shrinking from the centre towards to the extremities.

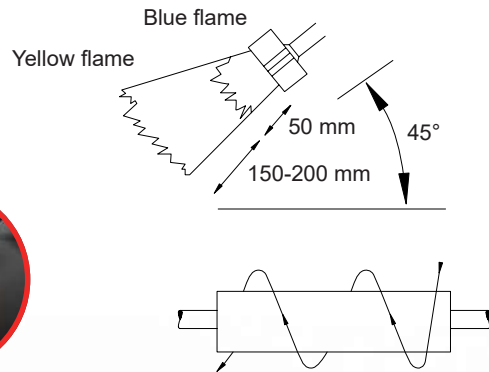

**TRIPLE WALL TUBE GT125**

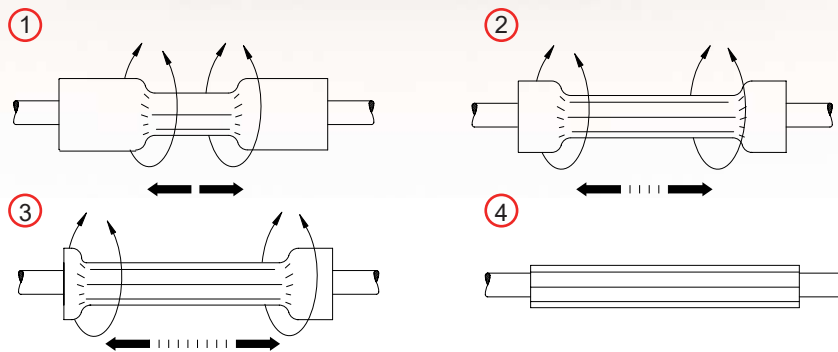
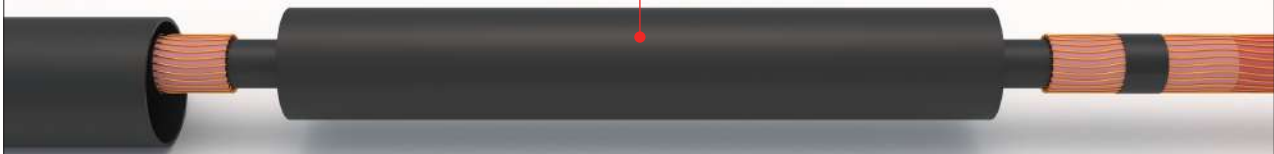

- To avoid over-heating of the heatshrinkable tube, keep the flame moving continuously and maintain an adequate distance with the angle of 45°.
- Heatshrink the tube from the center until obtaining a smooth surface.
- Continue the heatshrinking for circular sector of 100 mm alternating itself from both sides.
- At the end of the work, the surface of the heatshrinkable tube must be smooth.



● 3.5

Wrap the whole joint with metallic tape, using a 30% overlap, start and end on the edge of the triple wall tube. Make a knot to lock the metallic tape.

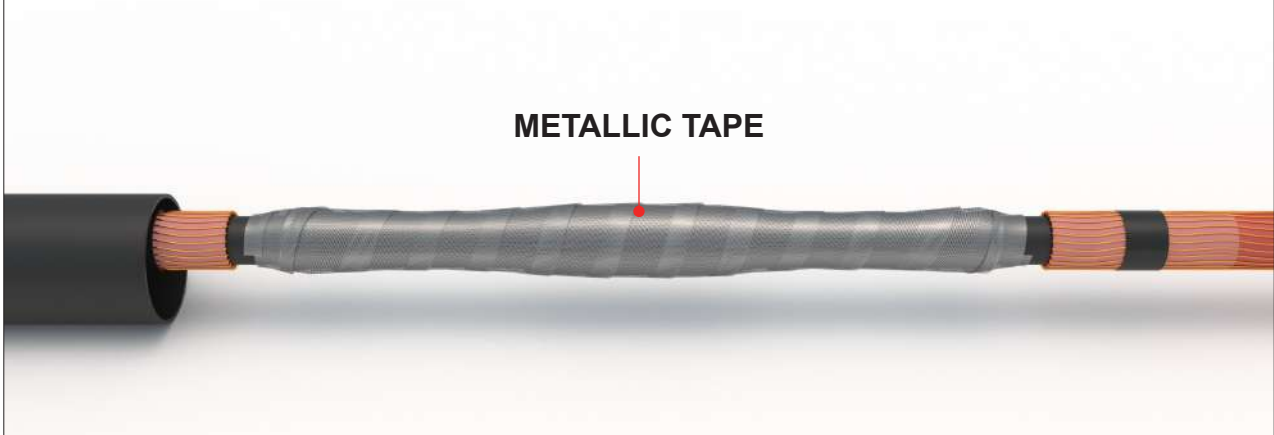

● 3.6

Apply a layer of sealing mastic "NGAF" at the ends of the cable outer sheath.



● 3.7

Remove the PVC tape previously applied to fix the screen wires. Fold back the screen wires towards the centre of the junction distributing them along the joint. Apply the screen connector.



● **4.1**

Clean the abraded area of the outer sheath.

● **4.2**

Apply one layer of sealing mastic "NGAF" starting overlapping 30mm the extremities of the outer sheaths till covering the screen wires for 50mm.

● **4.3**

Apply a layer of PVC tape "NAE" over the screen connector.





#### ● 4.4

Position the outer protection tube over the centre of the joint and start shrinking from the centre towards the ends.



#### OUTER PROTECTION TUBE WITH ADHESIVE

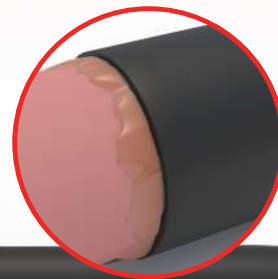
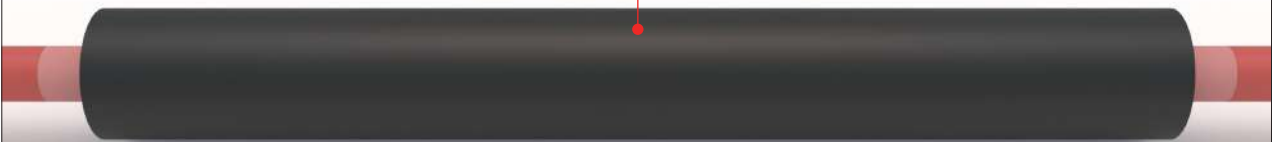

#### ● 4.5

The joint is complete. Allow to cool before moving.

Adjust torch to give a soft blue flame with yellow tip.  
Heatshrink tubes uniformly avoiding wrinkles along the surface.  
Keep the flame moving continuously and maintain adequate distance to avoid over heating.

This product should be installed by competent personnel familiar with electrical equipment and safe operating practices. Parts contained in this kit should be visually inspected for possible damage, and installed in accordance with these instructions. These instructions are not intended as a substitute for adequate training and experience.



Please dispose of all waste according to environmental regulations.

The company reserves the right to alter without notice the information contained in this installation manual.

**All Enquiries:**

**tel:** +44 (0)1744 762 929

**email:** [sales@etechcomponents.com](mailto:sales@etechcomponents.com)

**web:** [www.etechcomponents.com](http://www.etechcomponents.com)