

ENGLISH	Pg. 1
DEUTSCH	Pg. 7
FRANÇAISE	Pg. 9
ITALIANA	Pg. 11
ESPAÑOL	Pg. 13
ÈESKÝ	Pg. 15
NEDERLANDSE	Pg. 17
DANSKE	Pg. 19
SVENSKA	Pg. 21
SUOMEN	Pg. 23
NORSK	Pg. 25

Email:
techsupport@panduit.com

EU Website:
www.panduit.com/emea

EU Email:
emeatoolservicecenter@panduit.com

PANDUIT

www.panduit.com

Technical Support:
Tel: 1-800-777-3300

Panduit Europe • EMEA Headquarters
Tel: +31 (0) 546 580 452 • Fax: +31 (0) 546 580 441





SYSTEM SPECIFICATIONS 1

PRECAUTIONS AND GENERAL GUIDELINES 2

TOOL OPERATION 3

SYSTEM SPECIFICATIONS

Motor:	12 V DC motor
	3.7 lbs. / 1.8 kg (+ )

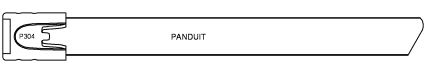
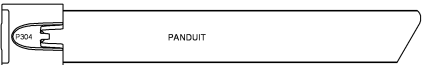
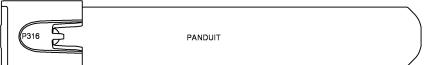
Panduit Pan-Steel MLT SERIES TIES ONLY		
MLTH (Heavy) 5/16" W (7.9mm)	MLTEH (Extra-Heavy) 1/2" W (12.7mm)	MLTSH (Super Heavy) 5/8" W (15.9mm)
		

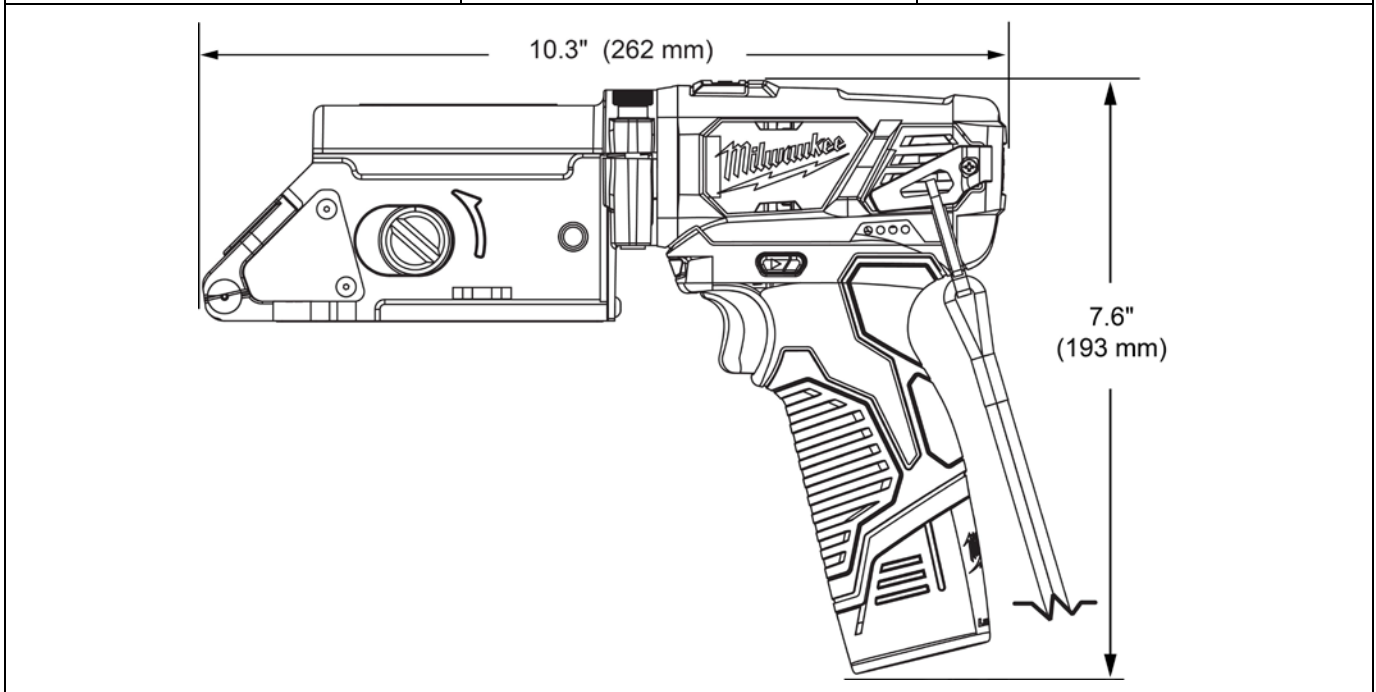

English	NOTE: In the interest of higher quality and value, Panduit products are continually being improved and updated. Consequently, pictures may vary from the enclosed product.
---------	--



Replacement *Milwaukee*® Batteries and Battery Chargers are available for purchase from local *Milwaukee*® products distributors or resellers.

Milwaukee® is a registered trademark of Milwaukee Electric Tool Corporation

The information contained in this literature is based on our experience to date and is believed to be reliable. It is intended as a guide for use by persons having technical skill at their own discretion and risk. We do not guarantee favorable results or assume any liability in connection with its use. Dimensions contained herein are for reference purposes only. For specific dimensional requirements consult the factory. This publication is not to be taken as a license to operate under, or a recommendation to infringe any existing patents. This supersedes and voids all previous literature, etc.

PRECAUTIONS AND GENERAL GUIDELINES

	This symbol is used to call your attention to hazards or unsafe practices which could result in an injury or property damage. The signal word, defined below, indicates the severity of the hazard. The message after the signal word provides information for preventing or avoiding the hazard.	
	WARNING	Hazards which, if not avoided, COULD result in severe injury or death.
	CAUTION	Hazards or unsafe practices which, if not avoided, MAY result in injury or property damage.

	WARNING	Read and understand all of the instructions and safety information in this manual before operating or servicing this tool.
	WARNING	Wear eye protection when operating or servicing this tool. Failure to wear eye protection can result in serious eye injury from flying debris.

WARNING	
<ul style="list-style-type: none"> Inspect tool before use. A worn or damaged tool may result in breakage striking the operator or nearby personnel. 	
CAUTION	
<ul style="list-style-type: none"> Do not perform any service or maintenance other than as described in this manual. Injury or damage to the tool may result. This tool is not designed for continuous use. The tool is designed for hand-held operation. Protect the tool from rain and moisture. Water will damage the tool and battery. Electric tools should not be operated in pouring rain or under water. Use this tool for the manufacturer's intended purpose only. 	



ENGLISH	TOOL OPERATION
DEUTSCH	BEDIENUNG DES WERKZEUGS
FRANÇAISE	FONCTIONNEMENT DE L'OUTIL
ITALIANA	AVVIAMENTO DELL'ATTREZZO
ESPAÑOL	OPERACIÓN DE LA HERRAMIENTA
ĚSKÝ	OBSLUHA NÁSTROJE
NEDERLANDSE	GEBRUIK VAN HET GEREEDSCHAP
DANSKE	BETJENING AF VÆRKTØJET
SVENSKA	VERKTYG MANÖVRERING
SUOMEN	TYÖKALUN KÄYTTÖ
NORSK	BETJENING AV MASKINEN

		<table border="1"> <tr> <td>H</td> <td>EH</td> <td>SH</td> </tr> <tr> <td>1 - 4</td> <td>3 - 6</td> <td>5 - 7</td> </tr> </table>	H	EH	SH	1 - 4	3 - 6	5 - 7
H	EH	SH						
1 - 4	3 - 6	5 - 7						
5/16" (7.9mm)	H	1 - 4						
1/2" (12.7mm)	EH	3 - 6						
5/8" (15.9mm)	SH	5 - 7						

