

EUROMOLD®

INTERFACE B
MEDIUM VOLTAGE COMPACT
SEPARABLE CONNECTORS

CATALOGUE 2022



Nexans
ELECTRIFY THE FUTURE



All Enquiries: tel: +44 (0)1744 762 929 | email: sales@etechcomponents.com | web: www.etechcomponents.com

COMPANY PRESENTATION



EUROMOLD

Euromold is the leading European specialised designer, manufacturer and distributor of prefabricated cable accessories for medium voltage energy distribution. Euromold provides a complete range of accessories for underground cables: premoulded EPDM rubber connectors for cables and epoxy bushings for transformers and switchgear, as well as a large range of cold-shrinkable terminations and joints from 12 to 42 kV.

Euromold is also the manufacturer of electrical components for the high voltage accessories of the Nexans group.

ISO 9001 Certificate

Since 1992, Euromold's commitment to quality is demonstrated by its ISO 9001 certification.

International standards

All our products meet the International standards like CENELEC HD 629.1, CENELEC EN 50180, IEC 60137, IEC 60502-4... or country specifications. Official certificates, CESI, KEMA, ATEX... prove the conformity of our products. Long duration tests of existing or new products are continuously performed in our test fields.

Laboratory accreditation

Since June 2000, Euromold's independent ELAB laboratory obtained the BELAC accreditation no.144-TEST conform with the European standards for laboratories ISO 17025 for electrical testing of low and medium voltage cable accessories according to the international standards EN 50393, IEC 60502-4, IEC 61442 and HD 629.



While every care is taken to ensure that the information contained in this publication is correct, no legal responsibility can be accepted for any inaccuracy. Nexans Network Solutions N.V. - Div. Euromold reserves the right to alter or modify the characteristics of its products described in this catalogue as standards and technology evolve.

SEPARABLE CONNECTORS AND BUSHINGS

INTERFACE B

TABLE OF CONTENTS

400LR - elbow connector
400T1 - equipment bushing
400AR-1 - equipment bushing
400AR-2 - equipment bushing
400AR-8 - equipment bushing
400SFR-P - equipment bushing
Accessories
Possible arrangements

INTERFACE B

Dimensions according to European CENELEC EN 50180 and 50181 (in mm).

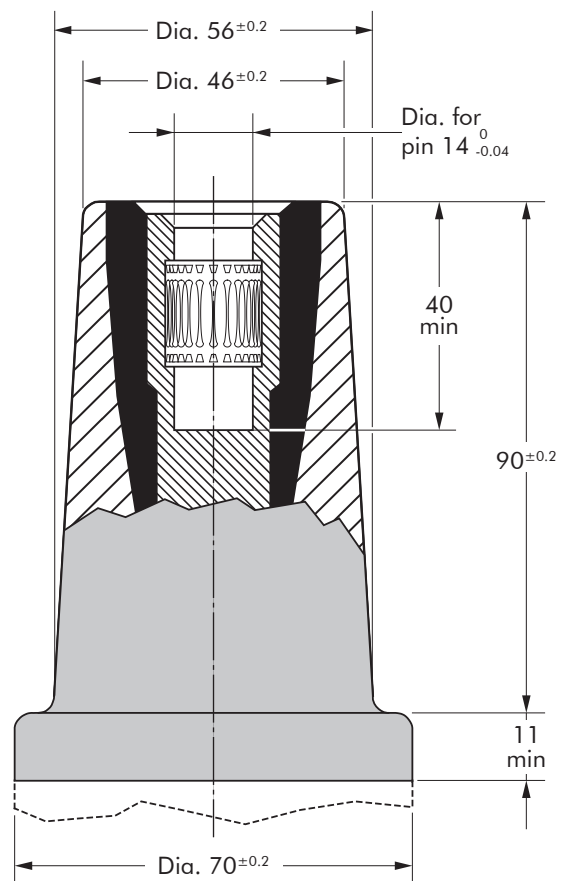

CONNECTING POSSIBILITIES

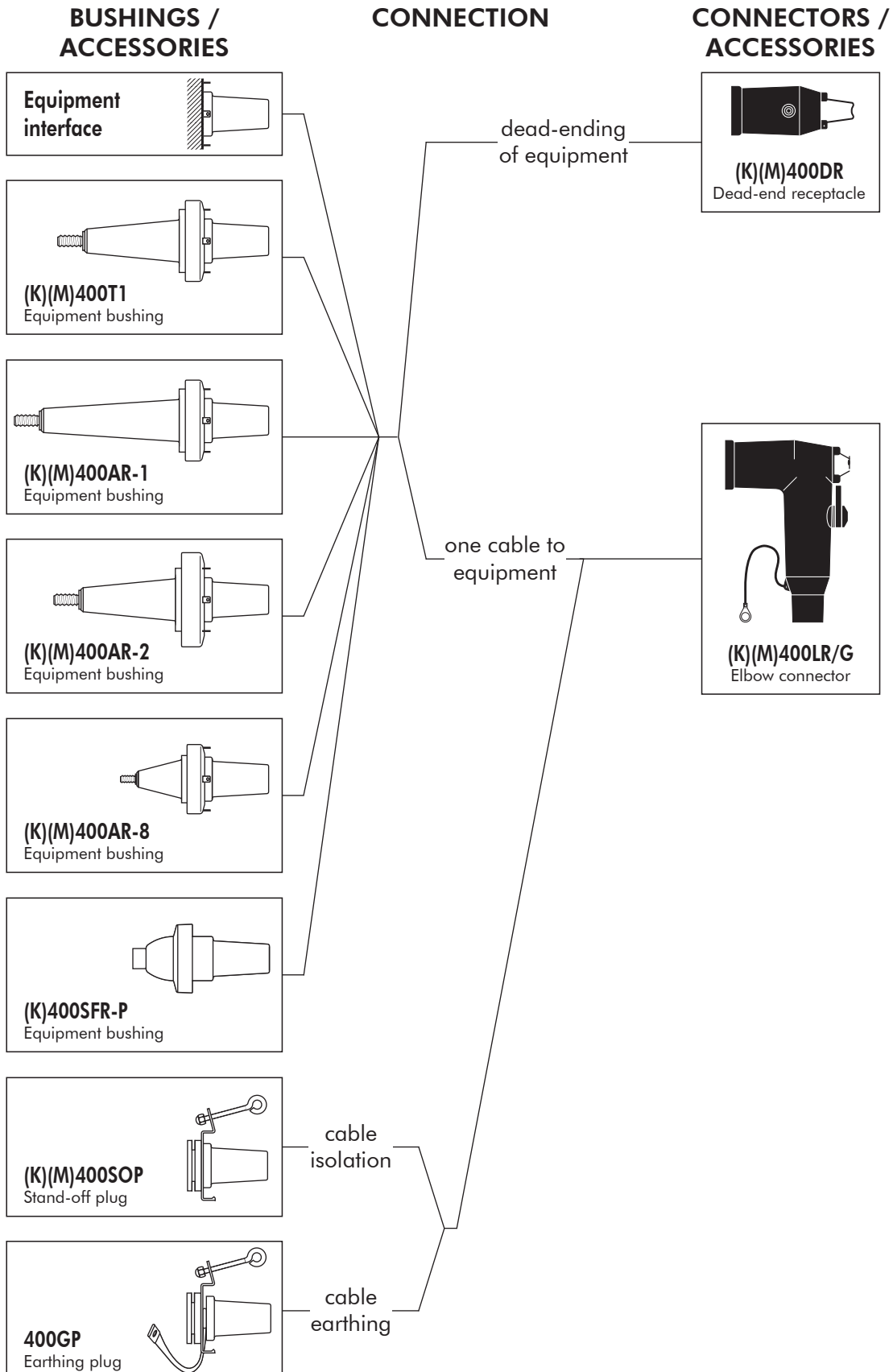

APPLICATION

Separable elbow connector (plug-in type) designed to connect polymeric insulated cable to equipment (transformers, switchgear, motors...).

TECHNICAL CHARACTERISTICS

- The thick conductive EPDM jacket provides a total safe to touch screen which ensures safety for personnel.
- Each separable connector is tested for AC withstand and partial discharge prior to leaving the factory.



DESIGN

Separable connector comprising:

1. Conductive EPDM insert.
2. Conductive EPDM jacket.
3. Insulating EPDM layer.
4. Type B - interface as described by CENELEC EN 50180 and 50181.
5. Conductor connector.
6. Cable reducer.
7. Earthing lead.
8. VD point.
9. Conductive rubber cap.

The screen break design enables cable outer sheath testing without removing or dismantling the connector.

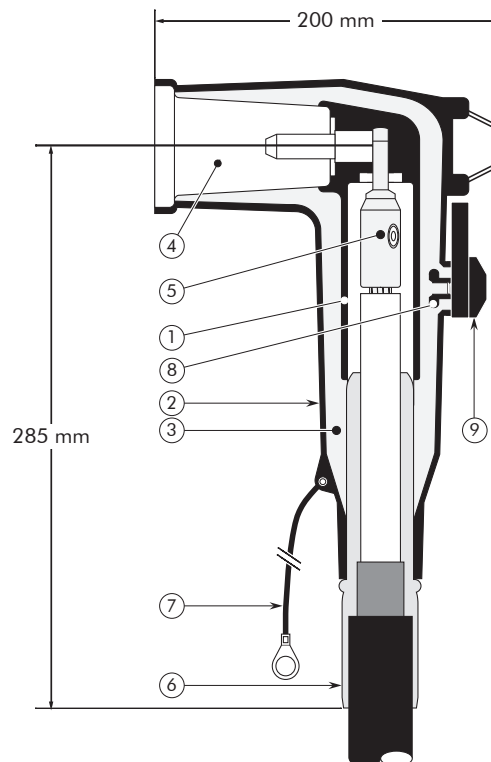

6/10 (12) kV
6.35/11 (12) kV
8.7/15 (17.5) kV
12/20 (24) kV
12.7/22 (24) kV
18/30 (36) kV
19/33 (36) kV

Up to 36 kV - 400 A

EUROMOLD®

SPECIFICATIONS AND STANDARDS

The separable connector 400LR meets the requirements of CENELEC HD 629.1.

Separable connector type	Voltage U_m (kV)	Current I_r (A)	Conductor sizes (mm ²)	
			min	max
400LR/G	12	400	25	240
K400LR/G	24	400	25	240
M400LR/G	36	400	35	185

01/2022

KIT CONTENTS

The complete (K)(M)400LR/G elbow connector kit comprises the following components:

The kit also comprises silicone grease, gloves, wipers, roll adhesive tape and installation instructions.

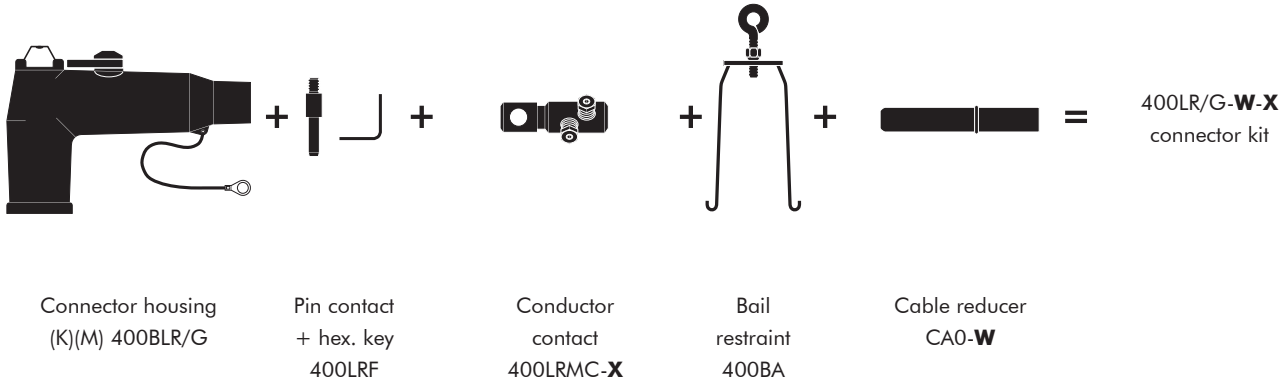

ORDERING INSTRUCTIONS

To order the elbow connector, select the part number which gives the best centring to the cable core insulation diameter and substitute **X** using table X, according to the conductor size and type. Add a 'K' for use up to 24 kV, add an 'M' for use up to 36 kV.

TABLE W

Ordering part number	Dia. over core insulation (mm)	
	min	max
400LR/G-011-X	12.0	19.0
400LR/G-015-X	16.0	26.5
400LR/G-018-X	19.0	32.6
400LR/G-021-X	22.0	34.6
400LR/G-027-X	28.5	37.5

EXAMPLE:

The cable is 24 kV, 185 mm² stranded copper with a diameter over core insulation of 27.5 mm. Order a K400LR/G-018-95.240UN5 elbow connector kit.

TABLE X

Conductor sizes (mm ²)	Aluminium and copper conductor	
	Bolted	
25	25.95UN5	
35		
50		
70		
95		
120		95.240UN5
150		
185		
240		

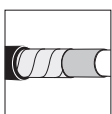

For use with copper tape screened cables. Order: Kit MT.

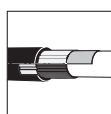

For use with Alupe or C 33-226 cables. Please contact our representative.



For use with other cable types. Please contact our representative.



For applications outdoors and in humid climate. Order: +MWS.



Components can be ordered individually.

400T1/400AR-1 /400AR-2

INTERFACE B2 EQUIPMENT BUSHINGS

APPLICATION

For use in equipment insulated with oil fluid, typically for transformers, switchgear, capacitors...

TECHNICAL CHARACTERISTICS

Each bushing is tested for AC withstand and partial discharge prior to leaving the factory.



SPECIFICATIONS AND STANDARDS

The plug-in type equipment bushings are moulded epoxy insulated parts and meet the requirements of IEC 60137. The (K)(M)400T1 also meets CENELEC EN 50180 .

ORDERING INSTRUCTIONS

To order the equipment bushing, specify the type.
The bushings are supplied with an earth jumper (/J) or an earth plate (/GS). This earth connection must be specified when ordering.
E.g. K400AR-1/J.

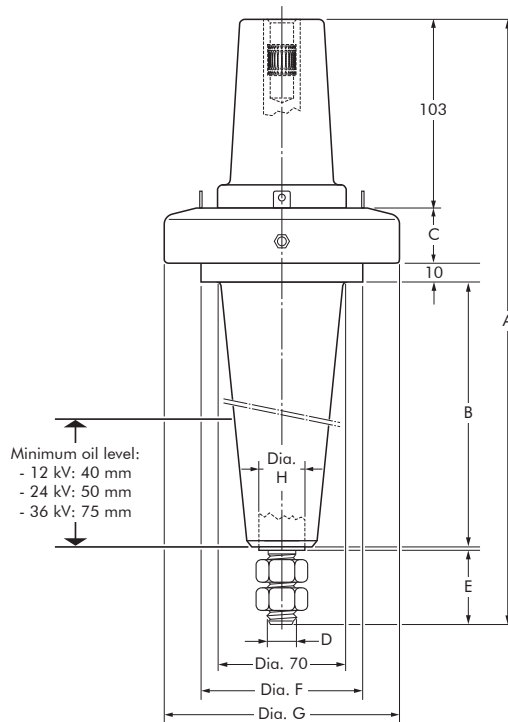

6/10 (12) kV
6.35/11 (12) kV
8.7/15 (17.5) kV
12/20 (24) kV
12.7/22 (24) kV
18/30 (36) kV

Up to 36 kV - 400 A

EUROMOLD®

In mm.

Equip-ment bushing type	Voltage Um (kV)	Current Ir (A)	Dimensions (mm)							
			A	B	C	D	E	Dia. F	Dia. G	Dia. H
400T1	12	400	310	144	30	M12	22	88	128	16
K400T1	24	400	310	144	30	M12	22	88	128	16
M400T1	36	400	310	144	30	M12	22	88	128	16
400AR-1	12	400	380	213	30	M12	22	74	128	16
K400AR-1	24	400	380	213	30	M12	22	74	128	16
M400AR-1	36	400	380	213	30	M12	22	74	128	16
400AR-2	12	400	329	138	36	M16	40	100	150	30
K400AR-2	24	400	329	138	36	M16	40	100	150	30
M400AR-2	36	400	329	138	36	M16	40	100	150	30

01/2022

FIXINGS FOR EQUIPMENT BUSHINGS

400AR-2/GS BUSHING

400AR-2/J BUSHING

400AR-1/J AND 400T1/J BUSHINGS

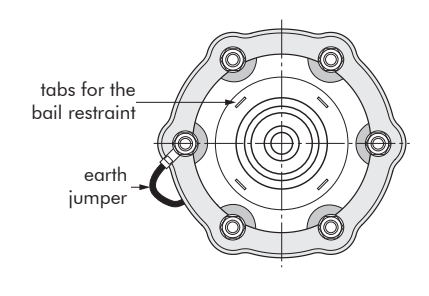
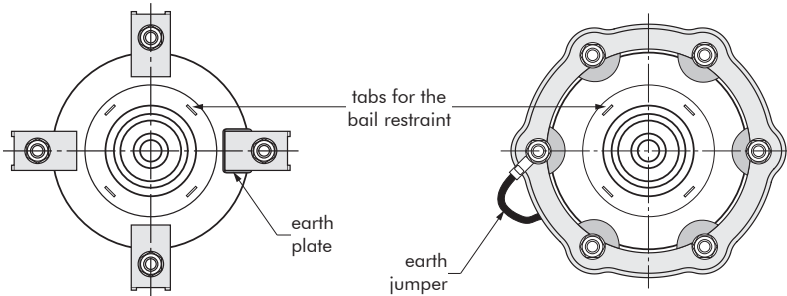
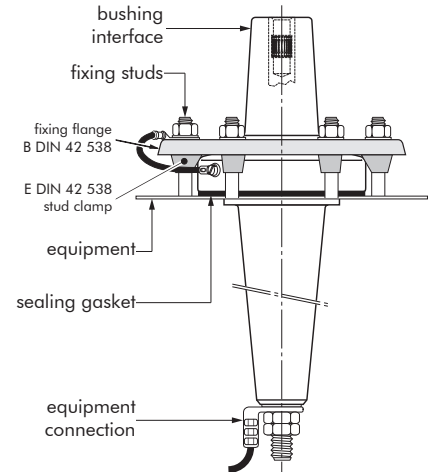
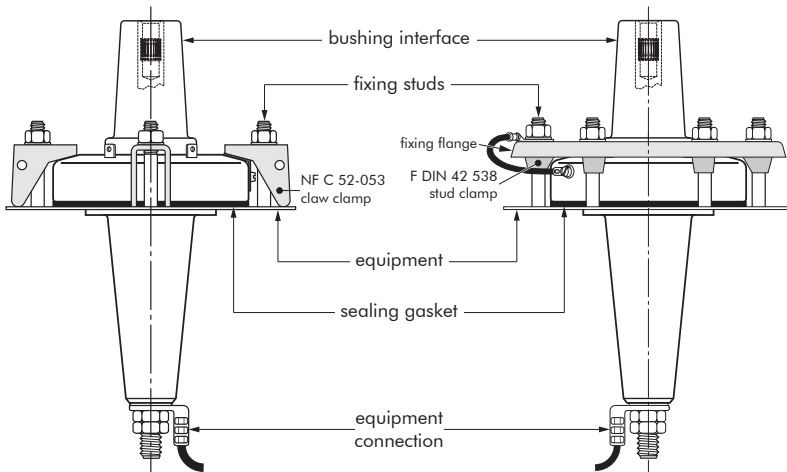

BUSHING CLAMPING KIT

To order the bushing clamping kit, according to NF C 52-053 standards, simply specify: KBC-NFC 52-053 /400 SERIES (for bushing type 400AR-2).
Contents: - 4 x claw clamp NF
- 1 x sealing gasket.

BUSHING CLAMPING KIT

To order the bushing clamping kit, simply specify: KBC-RING CLAMP 3.
Contents: - 1 x fixing flange
Ø150 mm
- 6 x stud clamp F
- 1 x sealing gasket.

BUSHING CLAMPING KIT

To order the bushing clamping kit, according to DIN 42 538 standards, simply specify: KBC - RING CLAMP 2.
Contents: - 1 x fixing flange B
- 6 x stud clamp E
- 1 x sealing gasket.

FIXING DIMENSIONS STANDARDS NF C 52-053

French standards.

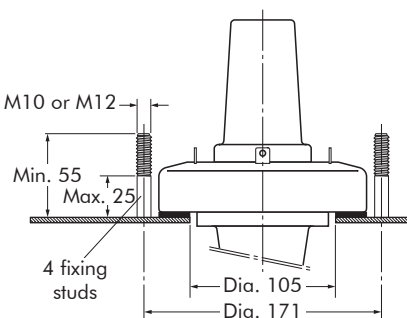

FIXING DIMENSIONS

French standards.

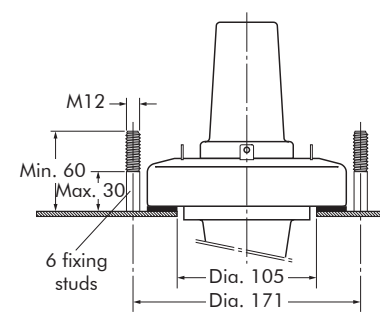

FIXING DIMENSIONS STANDARDS DIN 42 538

German standards.

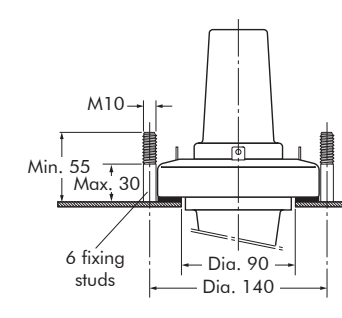

400AR-8

INTERFACE B EQUIPMENT BUSHING

APPLICATION

For use in equipment insulated with oil fluid, typically for transformers, switchgear, capacitors...

TECHNICAL CHARACTERISTICS

Each bushing is tested for AC withstand and partial discharge prior to leaving the factory.



SPECIFICATIONS AND STANDARDS

The plug-in type equipment bushings 400AR-8 are moulded epoxy insulated parts and meet the requirements of CENELEC EN 50180 and IEC 60137.

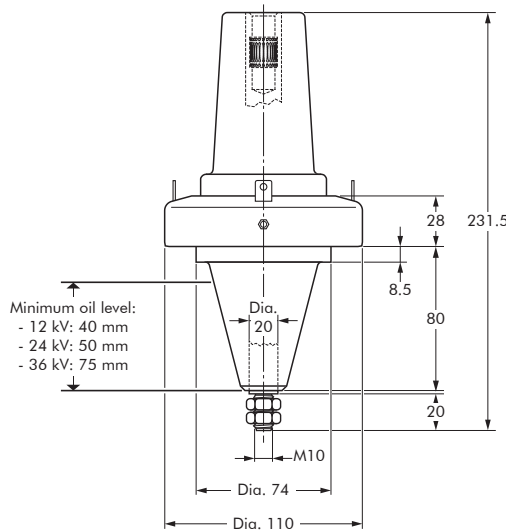

- 6/10 (12) kV
- 6,35/11 (12) kV
- 8,7/15 (17,5) kV
- 12/20 (24) kV
- 12,7/22 (24) kV
- 18/30 (36kV)
- 19/33 (36kV)

Up to 36 kV - 250 A

EUROMOLD®

ORDERING INSTRUCTIONS

To order the equipment bushing, specify the type.
 The bushings can be supplied with an earth jumper (/J).
 E.g. M400AR-8/J.

In mm.

Equipment bushing type	Voltage Um (kV)	Current Ir (A)
400AR-8	12	250
K400AR-8	24	250
M400AR-8	36	250

01/2022

FIXINGS FOR EQUIPMENT BUSHINGS

400AR-8/J BUSHING

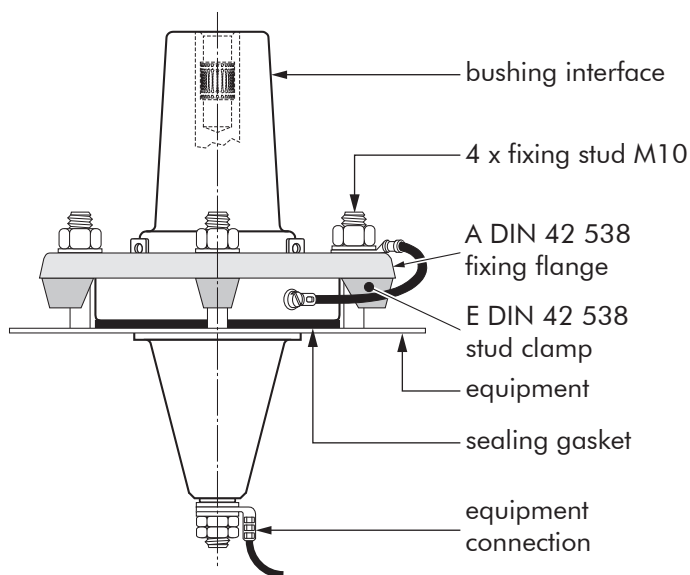

BUSHING CLAMPING KIT

To order the bushing clamping kit, according to DIN 42 538 standards, simply specify: KBC - RING CLAMP 1 DIN 42538.

Contents: - 1 x fixing flange A
- 4 x stud clamp E
- 1 x sealing gasket.

FIXING DIMENSIONS STANDARDS DIN 42 538

German standards.

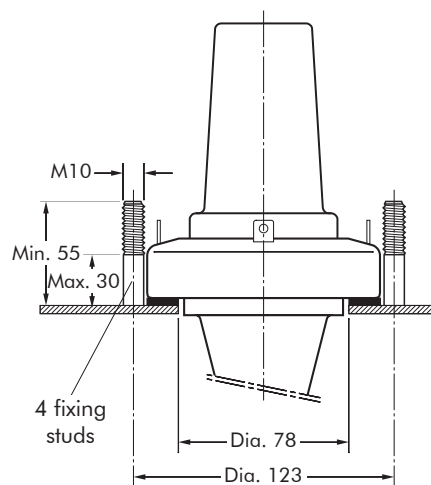
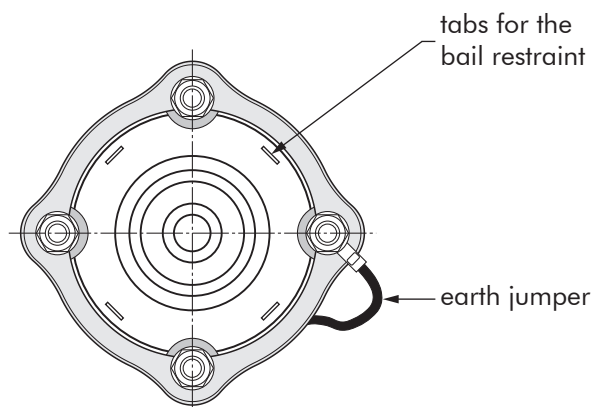

In mm.

400SFR-P

INTERFACE B EQUIPMENT BUSHING

APPLICATION

For use in equipment insulated with SF₆ gas.

TECHNICAL CHARACTERISTICS

Each bushing is tested for AC withstand and partial discharge prior to leaving the factory.



DESIGN

The equipment bushing is a moulded epoxy insulated part with a connector interface in accordance with CENELEC EN 50181. The 400SFR-P bushing has a shank outside this standard, adapted for use in SF₆ gas.

SPECIFICATIONS AND STANDARDS

The plug-in type equipment bushing 400SFR-P meets the requirements of CENELEC EN 50180 and IEC 60137.

ORDERING INSTRUCTIONS

To order the equipment bushing, simply specify the type.

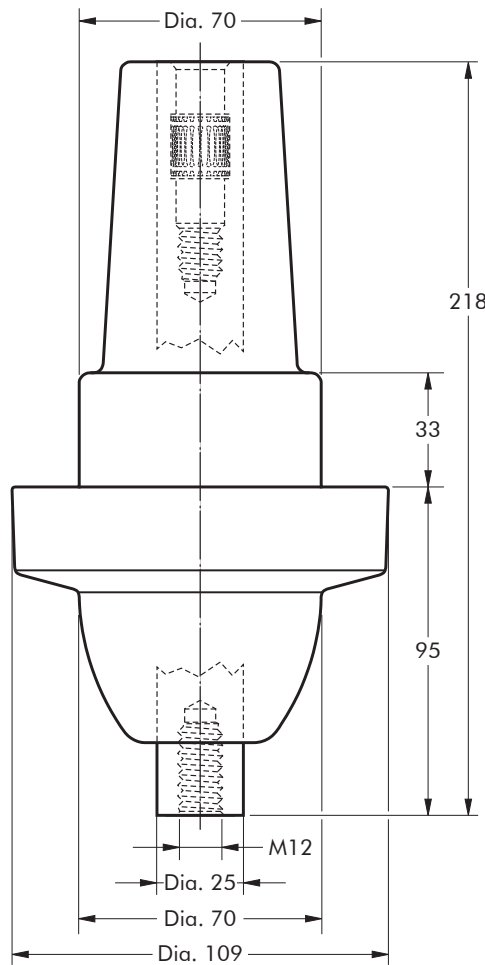

In mm.

6/10 (12) kV
6.35/11 (12) kV
8.7/15 (17.5) kV
12/20 (24) kV
12.7/22 (24) kV

Up to 24 kV - 400 A

EUROMOLD®

Equipment bushing type	Voltage U _m (kV)	Current I _r (A)
400SFR-P	12	400
K400SFR-P	24	400

01/2022

FIXINGS FOR EQUIPMENT BUSHINGS

400SFR-P BUSHING FOR GAS INSULATED SWITCHGEAR

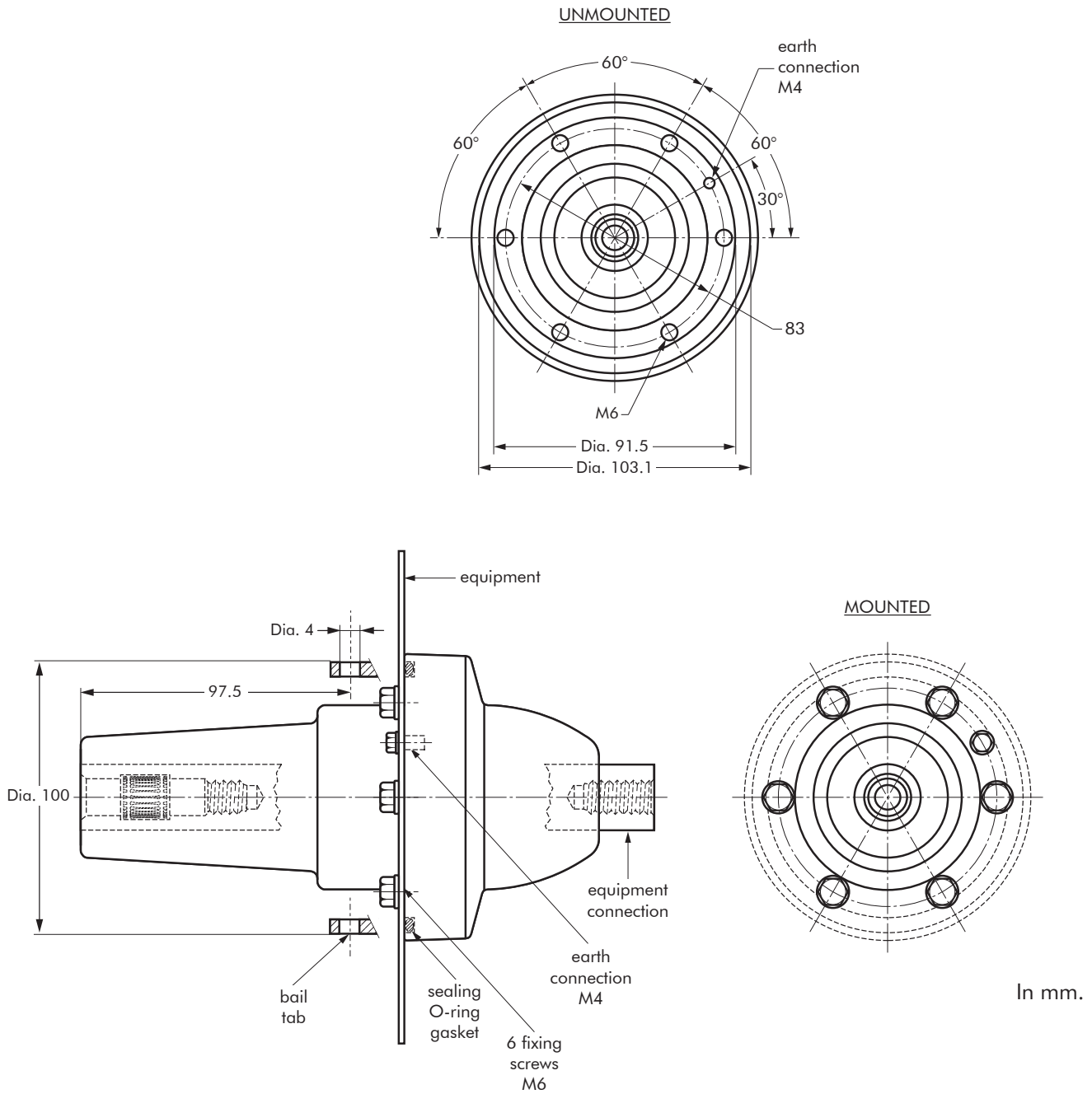

ACCESSORIES

APPLICATION

For use with connectors and bushings with an interface B as described by CENELEC EN 50180 and 50181.

TECHNICAL CHARACTERISTICS

All these products, except the earthing plug, are tested for AC withstand and partial discharge prior to leaving the factory.

6/10 (12) kV
6.35/11 (12) kV
8.7/15 (17.5) kV
12/20 (24) kV
12.7/22 (24) kV
18/30 (36) kV
19/33 (36) kV

Up to 36 kV

400DR DEAD-END RECEPTACLE

Fits over a bushing with a type B interface to provide 'dead-end' facility.

Is used with a 400BA restraint bail.

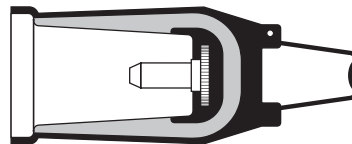

ORDERING INSTRUCTIONS

Order 400DR for 12 kV, K400DR for 24 kV or M400DR for 36 kV applications.
Can be supplied with integral earth lead: add -/G.

400SOP STAND-OFF PLUG

Is designed to support and 'dead-end' connectors with a type B interface when removed from equipment.

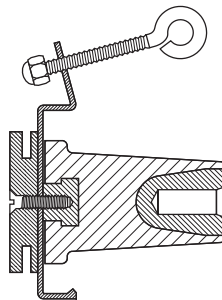

ORDERING INSTRUCTIONS

Order 400SOP for 12 kV, K400SOP for 24 kV or M400SOP for 36 kV applications.

400GP EARTHING PLUG

Is designed to support and earth connectors with a type B interface when removed from equipment.

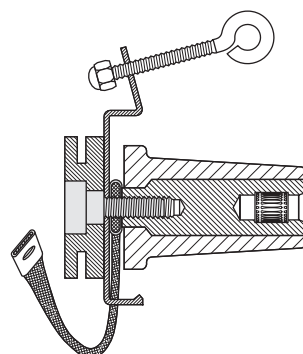

ORDERING INSTRUCTIONS

Order 400GP for 12 kV, 24 or 36 kV applications.

01/2022

KIT MT EARTHING KIT FOR COPPER TAPE SCREENED CABLES

Contains a tinned copper braid (25 mm² - L=500 mm), a tinned copper wire for cleating and water sealing mastic.

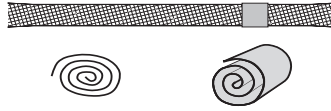

ORDERING INSTRUCTIONS

Order
Kit MT for 12 kV, 24 kV
or 36 kV applications.

POSSIBLE ARRANGEMENTS

CONNECTOR ON STAND-OFF PLUG

Order 400SOP for 12 kV,
K400SOP for 24 kV or M400SOP
for 36 kV applications.

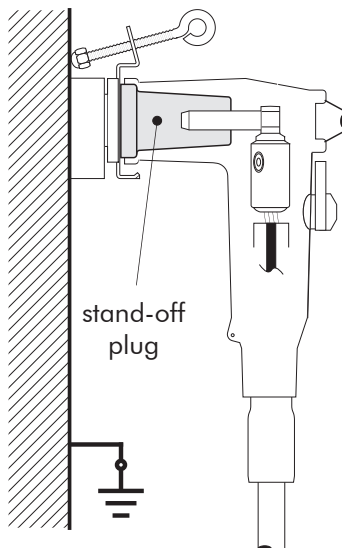

CONNECTOR ON EARTHING PLUG

Order 400GP for 12 kV, 24 kV and
36 kV applications.

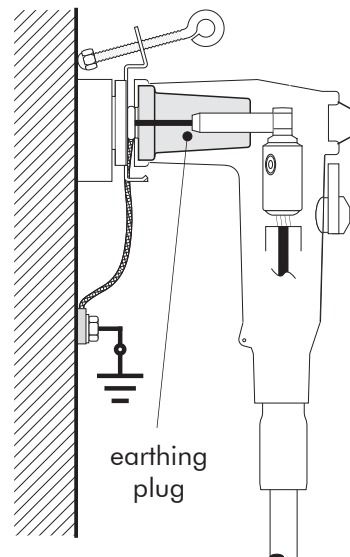

In mm.

01/2022

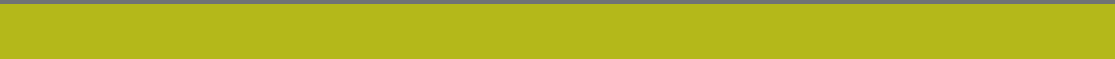

ELECTRIFY THE FUTURE



All Enquiries: tel: +44 (0)1744 762 929 | email: sales@etechcomponents.com | web: www.etechcomponents.com