

# EUROMOLD®

INTERFACE F  
MEDIUM VOLTAGE SEPARABLE  
CONNECTORS AND BUSHINGS

CATALOGUE 2021



**Nexans**  
ELECTRIFY THE FUTURE



All Enquiries: tel: +44 (0)1744 762 929 | email: [sales@etechcomponents.com](mailto:sales@etechcomponents.com) | web: [www.etechcomponents.com](http://www.etechcomponents.com)

# COMPANY PRESENTATION



## EUROMOLD

Euromold is the leading European specialised designer, manufacturer and distributor of prefabricated cable accessories for medium voltage energy distribution. Euromold provides a complete range of accessories for underground cables: premoulded EPDM rubber connectors for cables and epoxy bushings for transformers and switchgear, as well as a large range of cold-shrinkable terminations and joints from 12 to 42 kV.

Euromold is also the manufacturer of electrical components for the high voltage accessories of the Nexans group.

## ISO 9001 Certificate

Since 1992, Euromold's commitment to quality is demonstrated by its ISO 9001 certification.

## International standards

All our products meet the International standards like CENELEC HD 629.1, CENELEC EN 50180, IEC 60137, IEC 60502-4... or country specifications. Official certificates, CESI, KEMA, ATEX... prove the conformity of our products. Long duration tests of existing or new products are continuously performed in our test fields.

## Laboratory accreditation

Since June 2000, Euromold's independent ELAB laboratory obtained the BELAC accreditation no.144-TEST conform with the European standards for laboratories ISO 17025 for electrical testing of low and medium voltage cable accessories according to the international standards EN 50393, IEC 60502-4, IEC 61442 and HD 629.



While every care is taken to ensure that the information contained in this publication is correct, no legal responsibility can be accepted for any inaccuracy. Nexans Network Solutions N.V. - Div. Euromold reserves the right to alter or modify the characteristics of its products described in this catalogue as standards and technology evolve.

# SEPARABLE CONNECTORS AND BUSHINGS

## INTERFACE F

### TABLE OF CONTENTS

- 909TB - tee connector
- 909PB - coupling connector
- 944TB - tee connector
- 900AR-1 - equipment bushing
- 900AR-2 - equipment bushing
- 900AR-3 - equipment bushing
- 900AR-4 - equipment bushing
- Accessories
- Possible arrangements

### INTERFACE F1, F2 & F3

Dimensions according to European CENELEC EN 50180 and 50181 (in mm).

Interface type	Voltage $U_m$ (kV)	Current $I_r$ (A)	Dia. D (mm)
F1	36	2500	50
F2	52	630	22 min
F3	52	1250	32

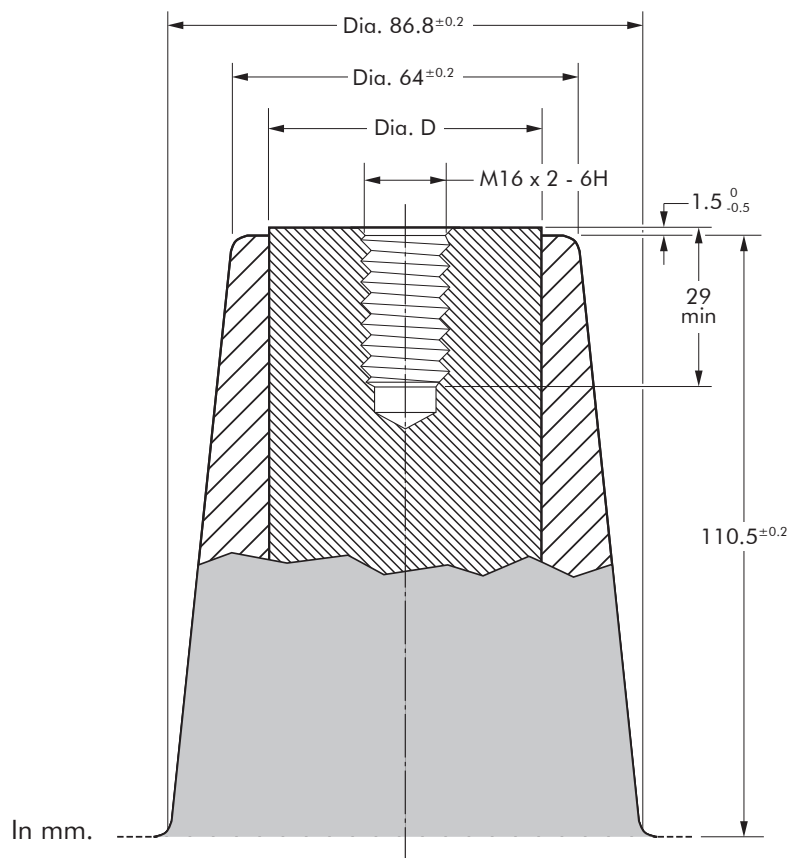

# (K)(M)(P)909TB

## INTERFACE F TEE CONNECTOR

### APPLICATION

Separable tee shape connector (bolted type) designed to connect polymeric insulated cable to equipment (transformers, switchgear, motors, ...). Also connects cable to cable when using the appropriate mating parts.

### DESIGN

Separable connector comprising:

1. Conductive EPDM insert.
2. Conductive EPDM jacket.
3. Insulating EPDM layer moulded between the insert and the jacket.
4. Type F interface, as described by CENELEC EN 50180 and 50181.
5. Conductor contact.
6. Basic insulating plug.
7. Cable reducer.
8. Conductive rubber cap.
9. Stud+flange nut.
10. Earthing lead.

The screen break design enables cable outer sheath testing without removing or dismantling the connector.

### SPECIFICATIONS AND STANDARDS

The 909TB separable connector meets the requirements of CENELEC HD 629.1.

### TECHNICAL CHARACTERISTICS

- The thick conductive EPDM jacket provides a total safe to touch screen which ensures safety for personnel.
- Each separable connector is tested for AC withstand and partial discharge prior to leaving the factory.

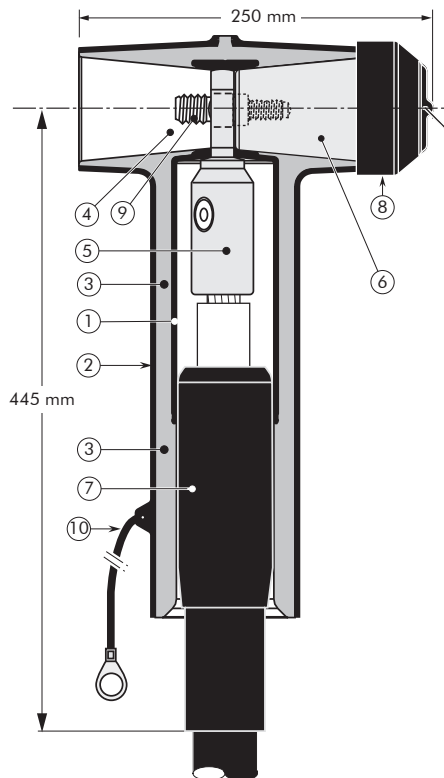

6/10 (12) kV  
 6.35/11 (12) kV  
 8.7/15 (17.5) kV  
 12/20 (24) kV  
 12.7/22 (24) kV  
 18/30 (36) kV  
 19/33 (36) kV  
 20.8/36 (42) kV

**Up to 42 kV - 2500 A**

**EUROMOLD®**

Separable connector type	Voltage Um (kV)	Current Ir (A)	Conductor sizes (mm <sup>2</sup> )	
			min	max
909TB/G	12	630 -1250 - 2500	500	1200
K909TB/G	24	630 -1250 - 2500	400	1200
M909TB/G	36	630 -1250 - 2500	240	1200
P909TB/G	42	630 -1250	240	1200

02/2021

## KIT CONTENTS

The complete (K)(M)(P)909TB/G tee connector kit comprises the following components:

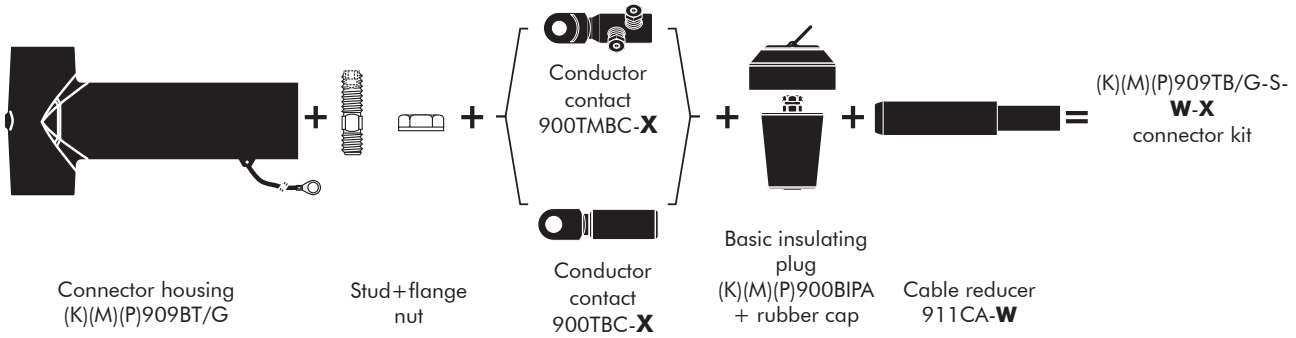

The kit also comprises silicone grease, field control mastic, gloves, roll adhesive tape, installation instructions and crimp chart.

## ORDERING INSTRUCTIONS

To order the tee connector, select the ordering part number which gives the best centring of the core insulation diameter and substitute **X** using table X, according to the conductor size and type. Add a 'K' for use up to 24 kV, add an 'M' for use up to 36 kV, add a 'P' for use up to 42 kV.

### EXAMPLE:

The copper wire screened cable is 36 kV, 1000 mm<sup>2</sup> stranded aluminium with a diameter over core insulation of 52 mm. Order M909TB/G-S-43-1000AL1 tee connector kit.

TABLE W

Ordering part number	Dia. over core insulation (mm)	
	min	max
909TB/G-S-32-X	35	43
909TB/G-S-37-X	40	48
909TB/G-S-43-X	46	54
909TB/G-S-50-X	53	59
909TB/G-S-53-X	56	62
909TB/G-S-56-X	59	65
909TB/G-S-59-X	62	68

TABLE X

Conductor sizes (mm <sup>2</sup> )	Aluminium conductor		Aluminium and copper conductor	Copper conductor
	Deep indent	DIN hexagonal	Bolted	DIN hexagonal
240	240BI1	240BI2	240.300UN5	240CU2
300	300BI1	300BI2		300CU2
400	400BI1	400BI2	400.630UN5	400CU2
500	500BI1	500BI2		500CU2
630	630BI1	630BI2	800.1000UN5	630CU2
800	800BI1	-		800CU2
1000	1000BI1	-	On request	1000CU2
1200	1200BI1	-		-

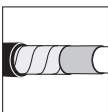

For use with copper tape screened cables. Order: Kit MT.



For applications outdoors and in humid climate. Order: +MWS.



For use with other cable types. Please contact our representative.



For use in potentially explosive atmospheres (for 12 kV max). Add -/ATEX to part number.



Components can be ordered individually.



When installed on an appropriate equipment bushing: 2500 A in dual cable arrangement

# (K)(M)(P)909PB

## INTERFACE F COUPLING CONNECTOR

### APPLICATION

Separable coupling connector (bolted type) for dual cable arrangement. It has been designed to be used with 909TB separable tee connectors.

### TECHNICAL CHARACTERISTICS

- The thick conductive EPDM jacket provides a total safe to touch screen which ensures safety for personnel.
- Each separable connector is tested for AC withstand and partial discharge prior to leaving the factory.



### DESIGN

Separable connector comprising:

1. Conductive EPDM insert.
2. Conductive EPDM jacket.
3. Insulating EPDM layer moulded between the insert and the jacket.
4. Interface to fit 909TB.
5. Conductor contact.
6. Basic insulating plug.
7. Cable reducer.
8. Conductive rubber cap.
9. Stud+nut+washer.
10. Earthing lead.

The screen break design enables cable outer sheath testing without removing or dismantling the connector.

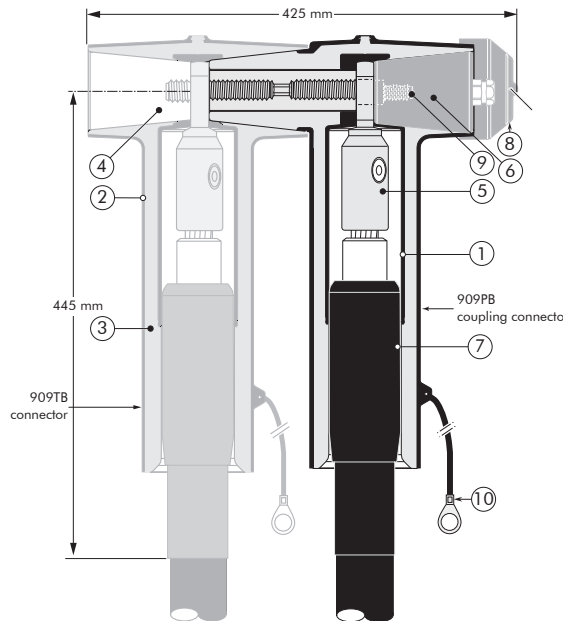

6/10 (12) kV  
6.35/11 (12) kV  
8.7/15 (17.5) kV  
12/20 (24) kV  
12.7/22 (24) kV  
18/30 (36) kV  
19/33 (36) kV  
20.8/36 (42) kV

Up to 42 kV - 2500 A

**EUROMOLD®**

### SPECIFICATIONS AND STANDARDS

The 909PB separable connector meets the requirements of CENELEC HD 629.1.

Separable connector type	Voltage $U_m$ (kV)	Current $I_r$ (A)	Conductor sizes (mm <sup>2</sup> )	
			min	max
909PB/G	12	630 - 1250 - 2500	500	1200
K909PB/G	24	630 - 1250 - 2500	400	1200
M909PB/G	36	630 - 1250 - 2500	240	1200
P909PB/G	42	630 - 1250	240	1200

02/2021

## KIT CONTENTS

The complete (K)(M)(P)909PB/G tee connector kit comprises the following components:

The kit also comprises silicone grease, field control mastic, gloves, roll adhesive tape, installation instructions and crimp chart.

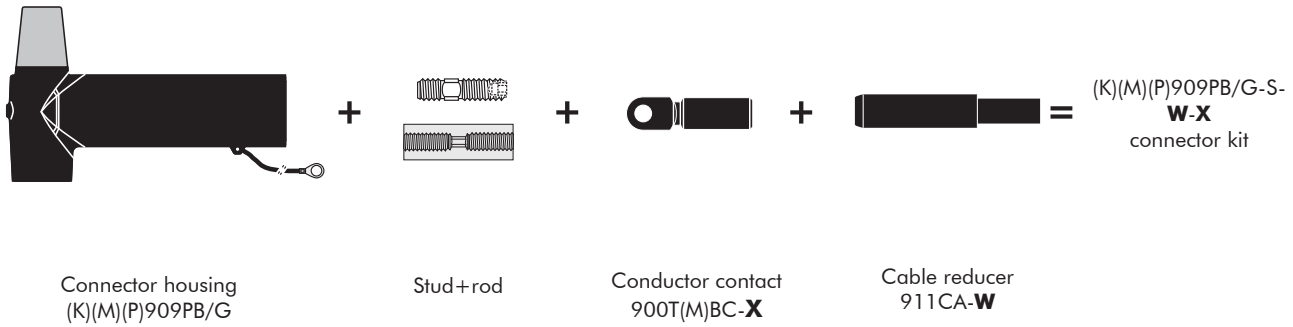

## ORDERING INSTRUCTIONS

To order the tee connector, select the ordering part number which gives the best centring of the core insulation diameter and substitute **X** using table X, according to the conductor size and type. Add a 'K' for use up to 24 kV, add an 'M' for use up to 36 kV, add a 'P' for use up to 42 kV.

TABLE W

Ordering part number	Dia. over core insulation (mm)	
	min	max
909PB/G-S-32-X	35	43
909PB/G-S-37-X	40	48
909PB/G-S-43-X	46	54
909PB/G-S-50-X	53	59
909PB/G-S-53-X	56	62
909PB/G-S-56-X	59	65
909PB/G-S-59-X	62	68

### EXAMPLE:

The copper wire screened cable is 36 kV, 1000 mm<sup>2</sup> stranded aluminium with a diameter over core insulation of 52 mm. Order M909PB/G-S-43-1000AL1 tee connector kit.

TABLE X

Conductor sizes (mm <sup>2</sup> )	Aluminium conductor		Aluminium and copper conductor	Copper conductor
	Deep indent	DIN hexagonal	Bolted	DIN hexagonal
240	240BI1	240BI2	<b>240.300UN5</b>	240CU2
300	300BI1	300BI2		300CU2
400	400BI1	400BI2		400CU2
500	500BI1	500BI2	<b>400.630UN5</b>	500CU2
630	630BI1	630BI2		630CU2
800	800BI1	-		800CU2
1000	1000BI1	-	<b>800.1000UN5</b>	1000CU2
1200	1200BI1	-		On request

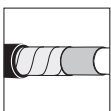

For use with copper tape screened cables. Order: Kit MT.



For use in potentially explosive atmospheres (for 12 kV max). Add -/ATEX to part number.



For use with other cable types. Please contact our representative.



For applications outdoors and in humid climate. Order: +MWS.



Components can be ordered individually.



When installed on an appropriate equipment bushing: 2500 A in dual cable arrangement

### APPLICATION

Separable tee shape connector designed to connect polymeric insulated cable to equipment (transformers, switchgear, motors, ...).

Also connects cable to cable when using the appropriate mating parts.

### TECHNICAL CHARACTERISTICS

- The thick conductive EPDM jacket provides a total safe to touch screen which ensures safety for personnel.
- Each separable connector is tested for AC withstand and partial discharge prior to leaving the factory.



### DESIGN

Separable connector comprising:

1. Conductive EPDM insert.
2. Conductive EPDM jacket.
3. Insulating EPDM layer moulded between the insert and the jacket.
4. Type F interface as described by CENELEC EN 50180 and 50181.
5. Conductor connector.
6. Clamping screw.
7. Cable reducer.
8. Basic insulating plug (with VD point), type C interface as described by CENELEC EN 50180 and 50181.
9. Conductive rubber cap.
10. Earthing lead.

The screen break design enables cable outer sheath testing without removing or dismantling the connector.

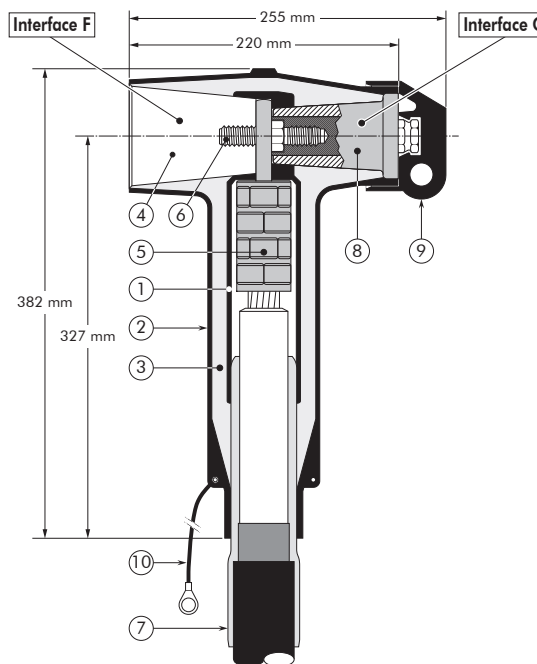

6/10 (12) kV  
6.35/11 (12) kV  
8.7/15 (17.5) kV  
12/20 (24) kV  
12.7/22 (24) kV  
18/30 (36) kV  
20.8/36 (42) kV

**Up to 42 kV - 2500 A**

**EUROMOLD®**

### SPECIFICATIONS AND STANDARDS

The 944TB/G separable connector meets the test requirements of CENELEC HD 629.1.

Separable connector type	Voltage $U_m$ (kV)	Current $I_r$ (A)	Conductor sizes (mm <sup>2</sup> )	
			min	max
944TB/G	12	2500	95	630
K944TB/G	24	2500	95	630
M944TB/G	36	2500	95	630
P944TB/G	42	1250	95	630

02/2021



## KIT CONTENTS

The complete tee connector kit comprises the following components:

The kit also comprises lubricant, wipers, installation instructions and crimp chart.

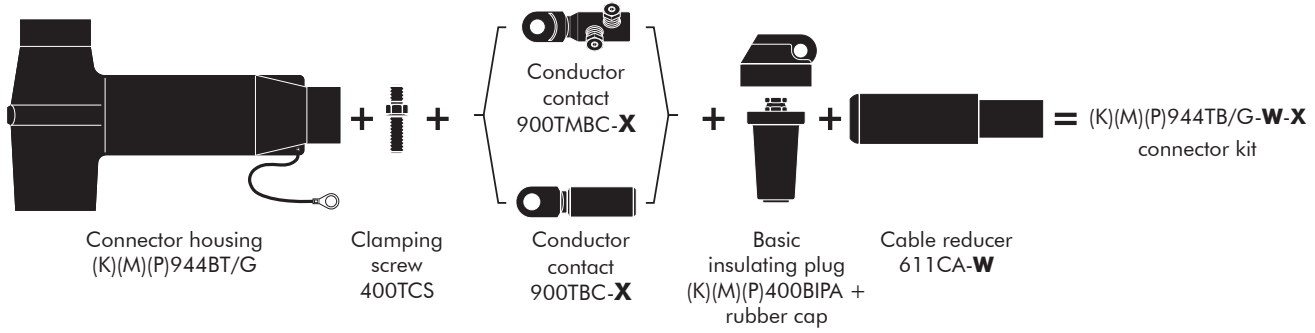

## ORDERING INSTRUCTIONS

To order the tee connector, select the ordering part number which gives you the best centring of your core insulation diameter and substitute **X** using table X, according to your conductor size and type. Add a 'K' for use up to 24 kV, add an 'M' for use up to 36 kV, add a 'P' for use up to 42 kV.

TABLE W

Ordering part number	Dia. over core insulation (mm)	
	min	max
944TB/G-15-X	16.0	22.0
944TB/G-19-X	20.0	26.5
944TB/G-22-X	23.5	31.0
944TB/G-27-X	28.5	37.5
944TB/G-32-X	34.0	42.5
944TB/G-37-X	39.0	48.5
944TB/G-43-X	45.5	56.0

### EXAMPLE:

The copper wire screened cable is 24 kV, 630 mm<sup>2</sup> stranded aluminium with a diameter over core insulation of 44.0 mm. Order a K944TB/G-37-630AL2 tee connector kit.

TABLE X

Conductor sizes (mm <sup>2</sup> )	Aluminium conductor		Aluminium and copper conductor	Copper conductor
	DIN hexagonal	Deep indent	Bolted	DIN hexagonal
95	95BI2	95BI1	50.150UN5 70.240UN5 120.300UN5 185.400UN5 400.630UN5	95CU2
120	120BI2	120BI1		120CU2
150	150BI2	150BI1		150CU2
185	185BI2	185BI1		185CU2
240	240BI2	240BI1		240CU2
300	300BI2	300BI1		300CU2
400	400BI2	400BI1		400CU2
500	500BI2	500BI1		500CU2
630	630BI2	630BI1	630CU2	

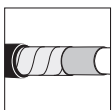

For use with copper tape screened cables. Order: Kit MT.

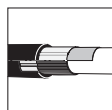

For use with Alupe or C 33-226 cables. Please contact our representative.

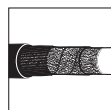

For use with fabric tape (graphite) screened cables. Order additional semi-conductive tape (type TSC).



For use with other cable types. Please contact our representative.



For applications outdoors and in humid climate. Order: +MWS.



Components can be ordered individually.

### APPLICATION

For use in equipment, typically for transformers, switchgear, capacitors...

### TECHNICAL CHARACTERISTICS

Each bushing is tested for AC withstand and partial discharge prior to leaving the factory.



### SPECIFICATIONS AND STANDARDS

The bolted type equipment bushings 900AR-X are moulded epoxy insulated parts and meet the requirements of CENELEC EN 50180 and IEC 60137.

### ORDERING INSTRUCTIONS

To order the equipment bushing, specify the type. Add a 'K' for use up to 24 kV, add an 'M' for use up to 36 kV, add a 'P' for use up to 42 kV. The bushings can be supplied with an earth jumper (/J) or an earth plate (/GS). This earth connection must be specified when ordering. E.g. 900AR-4/GS.

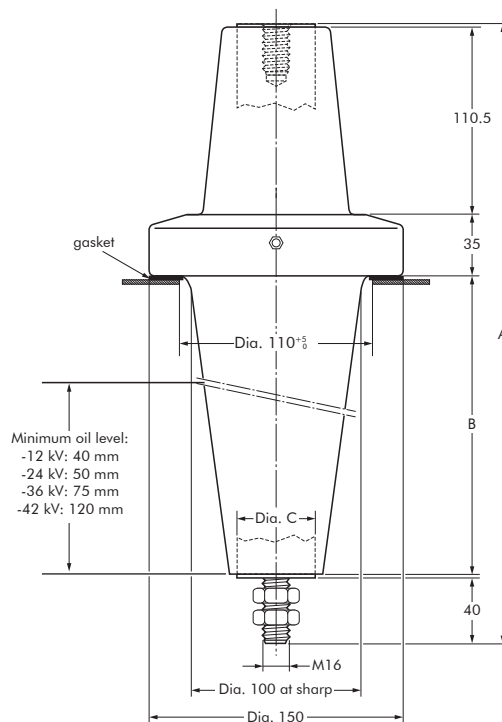

6/10 (12) kV  
6.35/11 (12) kV  
8.7/15 (17.5) kV  
12/20 (24) kV  
12.7/22 (24) kV  
18/30 (36) kV  
19/33 (36) kV  
20.8/36 (42) kV

Up to 42 kV - 2500 A

**EUROMOLD®**

In mm.

Equipment bushing type	Interface type	Voltage Um (kV)	Current Ir (A)	Dimensions (mm)		
				A	B	Dia. C
900AR-1	F3	42	1250	364	175	32
900AR-2	F2	42	630	364	175	25
900AR-3	F1	36	2500	364	175	50
900AR-4	F1	36	2500	259	70	50

# FIXINGS FOR EQUIPMENT BUSHINGS

## 900AR-X/GS BUSHING

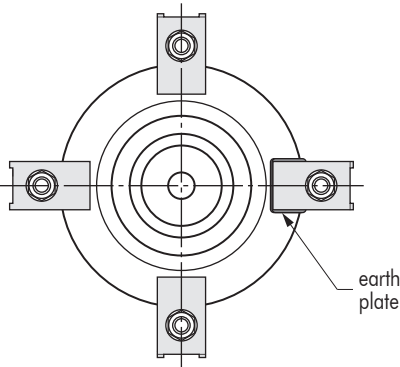
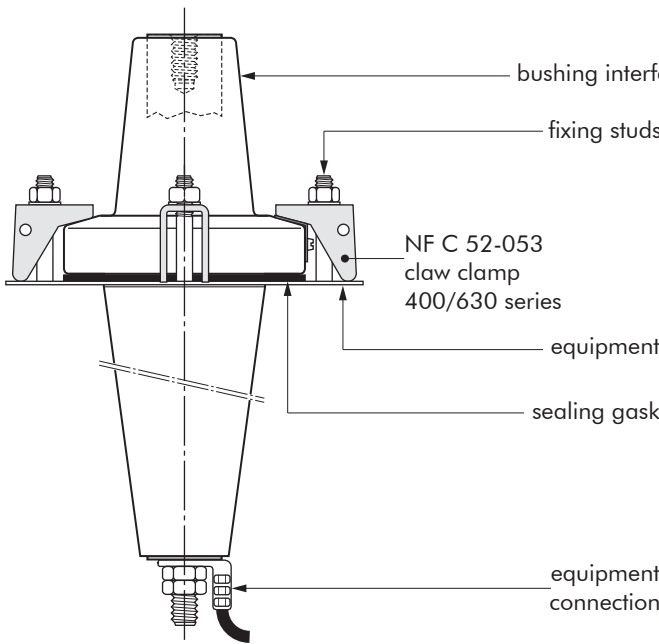

## 900AR-X/J BUSHING

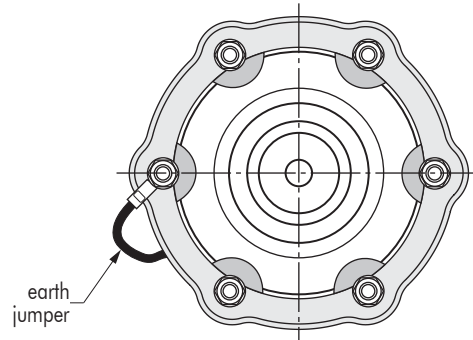
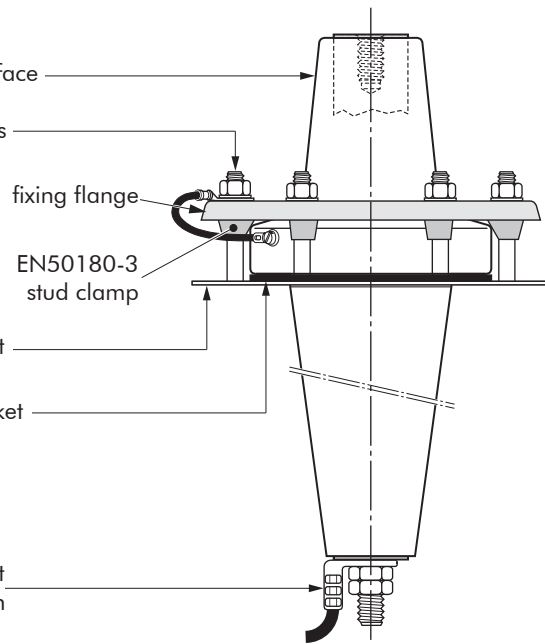

### BUSHING CLAMPING KIT

To order the bushing clamping kit, according to NF C 52-053 standards, simply specify: KBC - NFC 52-053 /400 SERIES.

Contents: - 4 x claw clamp NF400  
- 1 x sealing gasket.

### FIXING DIMENSIONS STANDARDS NF C 52-053

French standards.

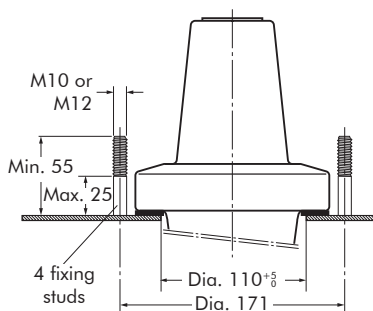

### BUSHING CLAMPING KIT

To order the bushing clamping kit with DIN style fixing flange, simply specify: KBC - RING CLAMP 3.

Contents: - 1 x fixing flange  
Ø150 mm  
- 6 x stud clamp  
EN50180-3  
- 1 x sealing gasket.

### FIXING DIMENSIONS

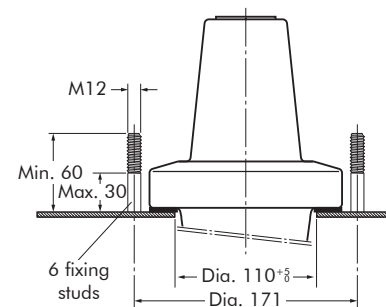

### APPLICATION

For use with connectors and bushings with an interface F as described by CENELEC EN 50180 and 50181.

### TECHNICAL CHARACTERISTICS

All these products, except the earthing plugs, are tested for AC withstand and partial discharge prior to leaving the factory.

6/10 (12) kV  
6.35/11 (12) kV  
8.7/15 (17.5) kV  
12/20 (24) kV  
12.7/22 (24) kV  
18/30 (36) kV  
19/33 (36) kV  
20.8/36 (42) kV

Up to 42 kV

## EUROMOLD®

### 900DR-B/G DEAD-END RECEPTACLE

Fits over a bushing with a type F interface to provide 'dead-end' facility. The dead-end receptacle is supplied with an earth lead.

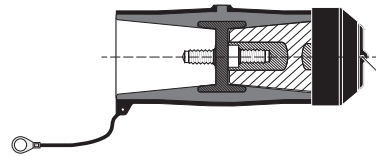

### ORDERING INSTRUCTIONS

Order  
900DR-B/G for 12 kV,  
K900DR-B/G for 24 kV,  
M900DR-B/G for 36 kV or  
P900DR-B/G for 42 kV  
applications.

### 900SOP-B STAND-OFF PLUG

Is designed to support and 'dead-end' connectors with a type F interface when removed from equipment.

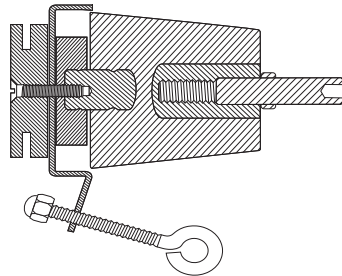

### ORDERING INSTRUCTIONS

Order  
900SOP-B for 12 kV,  
K900SOP-B for 24 kV,  
M900SOP-B for 36 kV or  
P900SOP-B for 42 kV  
applications.

### 900GP-B EARTHING PLUG

Is designed to support and earth connectors with a type F interface when removed from equipment.

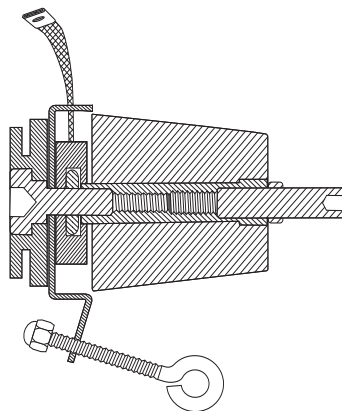

### ORDERING INSTRUCTIONS

Order  
900GP-B for 12, 24, 36 or  
42 kV applications.

Order  
900GP-SBT for a version with a  
straight ball terminal.

02/2021

## 900BE/G BUSHING EXTENDER

Provides an extension piece to allow cables to stand away from equipment. Is used in conjunction with the 900CP or 909PB. The bushing extender is supplied with an earth lead.

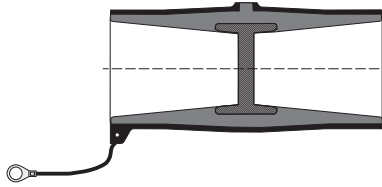

## ORDERING INSTRUCTIONS

Order

900BE/G for 12 kV,

K900BE/G for 24 kV

M900BE/G for 36 kV or

P900BE/G for 42 kV

applications.

Note: delivered with stud/nut/

washer.

# POSSIBLE ARRANGEMENTS

## 909TB/G

Single cable arrangement.

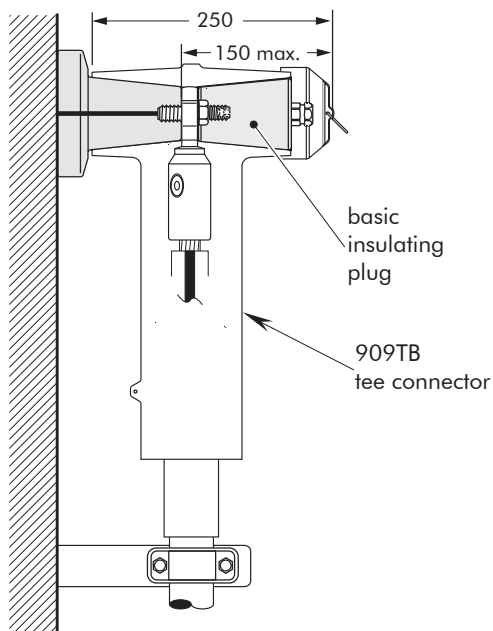

## 909TBM/G-P2

Dual cable arrangement.

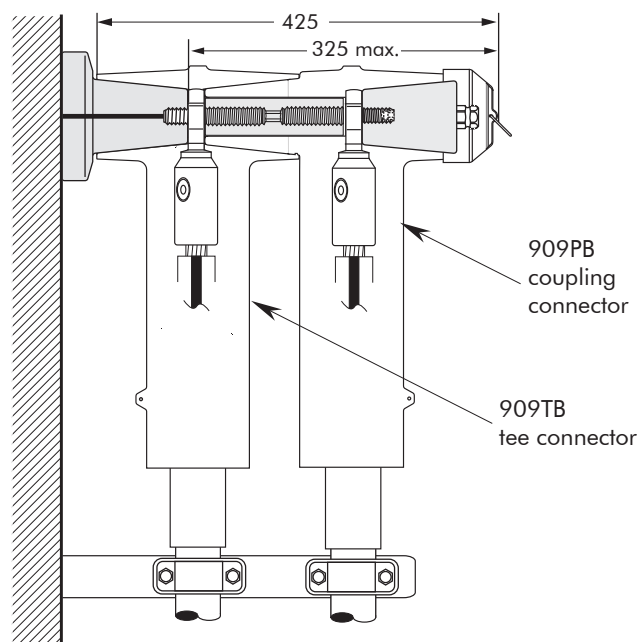

## 909TB/G+900BE/G

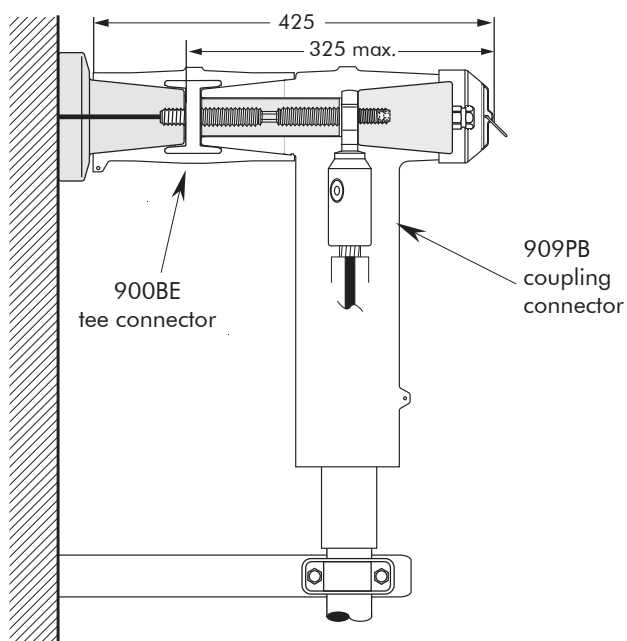

In mm.

02/2021

### 944TB/G

Single cable arrangement.  
Order 944TB/G for 12 kV,  
K944TB/G for 24 kV, M944TB/G  
for 36 kV or P944TB/G for 42 kV  
applications.

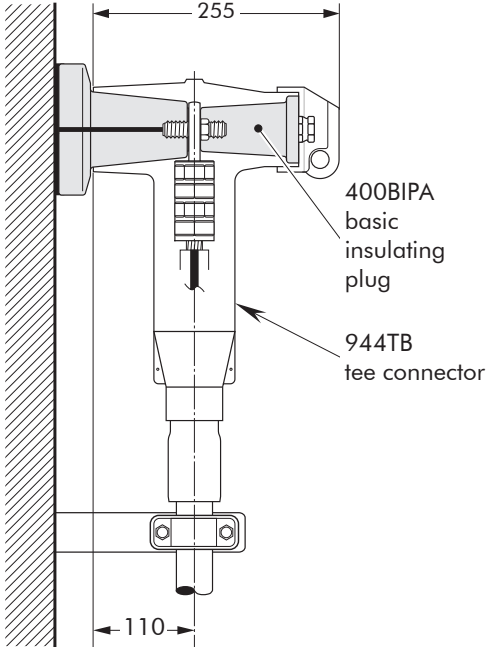

### 944TBM/G-P2

Dual cable arrangement.  
Order 944TBM/G-P2 for 12 kV,  
K944TBM/G-P2 for 24 kV,  
M944TBM/G-P2 for 36 kV or  
P944TBM/G-P2 for 42 kV  
applications.

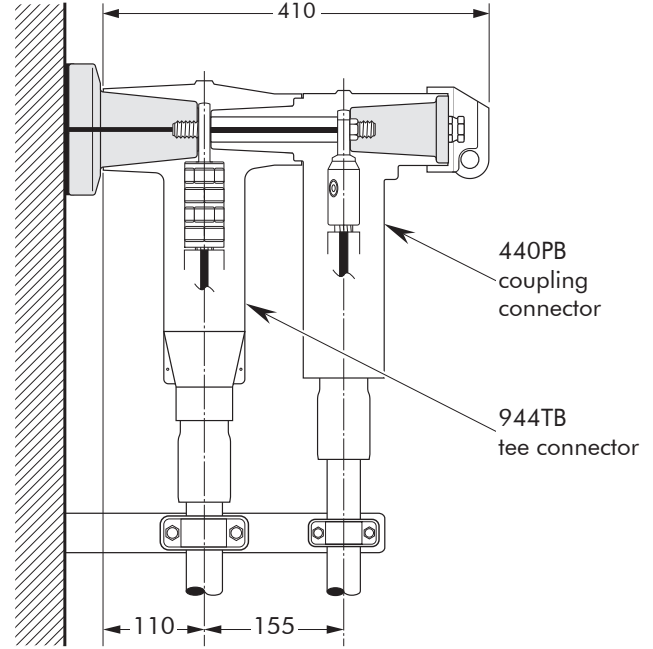

### 944TB/G-P2

Dual cable arrangement.  
Order 944TB/G-P2 for 12 kV,  
K944TB/G-P2 for 24 kV, M944TB/  
G-P2 for 36 kV or  
P944TB/G-P2 for 42 kV  
applications.

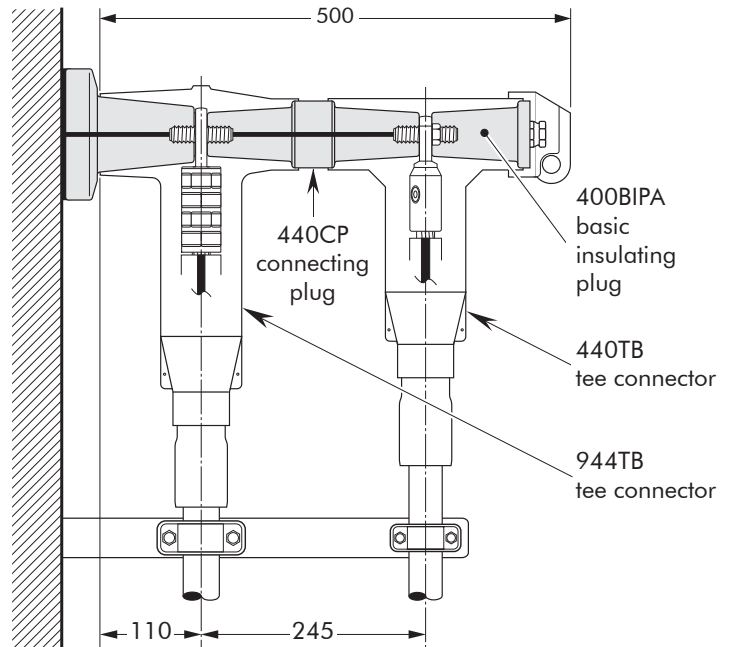

In mm.



ELECTRIFY THE FUTURE



All Enquiries: tel: +44 (0)1744 762 929 | email: [sales@etechcomponents.com](mailto:sales@etechcomponents.com) | web: [www.etechcomponents.com](http://www.etechcomponents.com)