

400T1/400AR-1 /400AR-2

INTERFACE B2 EQUIPMENT BUSHINGS

APPLICATION

For use in equipment insulated with oil fluid, typically for transformers, switchgear, capacitors...

TECHNICAL CHARACTERISTICS

Each bushing is tested for AC withstand and partial discharge prior to leaving the factory.



SPECIFICATIONS AND STANDARDS

The plug-in type equipment bushings are moulded epoxy insulated parts and meet the requirements of IEC 60137. The (K)(M)400T1 also meets CENELEC EN 50180 .

ORDERING INSTRUCTIONS

To order the equipment bushing, specify the type.

The bushings are supplied with an earth jumper (/J) or an earth plate (/GS). This earth connection must be specified when ordering.

E.g. K400AR-1/J.

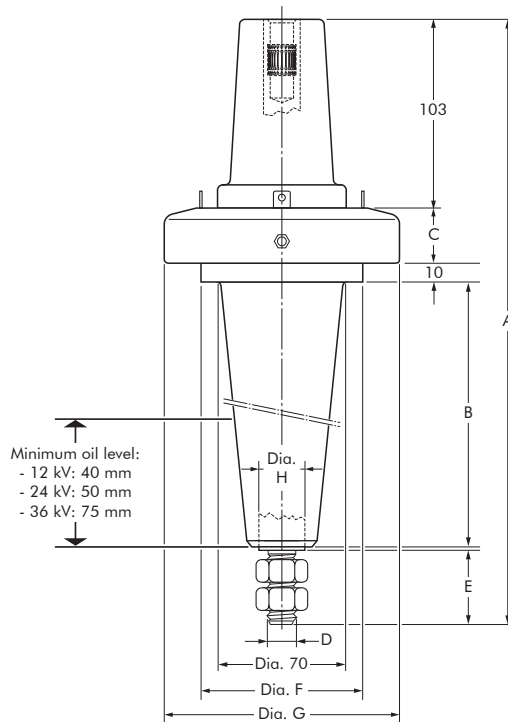

- 6/10 (12) kV
- 6.35/11 (12) kV
- 8.7/15 (17.5) kV
- 12/20 (24) kV
- 12.7/22 (24) kV
- 18/30 (36) kV

Up to 36 kV - 400 A

EUROMOLD®

In mm.

Equip-ment bushing type	Voltage Um (kV)	Current Ir (A)	Dimensions (mm)							
			A	B	C	D	E	Dia. F	Dia. G	Dia. H
400T1	12	400	310	144	30	M12	22	88	128	16
K400T1	24	400	310	144	30	M12	22	88	128	16
M400T1	36	400	310	144	30	M12	22	88	128	16
400AR-1	12	400	380	213	30	M12	22	74	128	16
K400AR-1	24	400	380	213	30	M12	22	74	128	16
M400AR-1	36	400	380	213	30	M12	22	74	128	16
400AR-2	12	400	329	138	36	M16	40	100	150	30
K400AR-2	24	400	329	138	36	M16	40	100	150	30
M400AR-2	36	400	329	138	36	M16	40	100	150	30

01/2022

FIXINGS FOR EQUIPMENT BUSHINGS

400AR-2/GS BUSHING

400AR-2/J BUSHING

400AR-1/J AND 400T1/J BUSHINGS

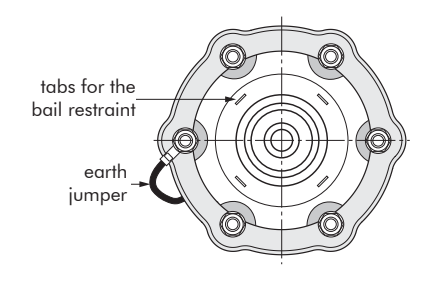
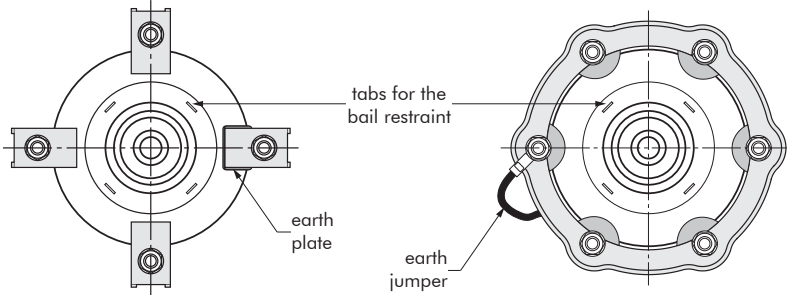
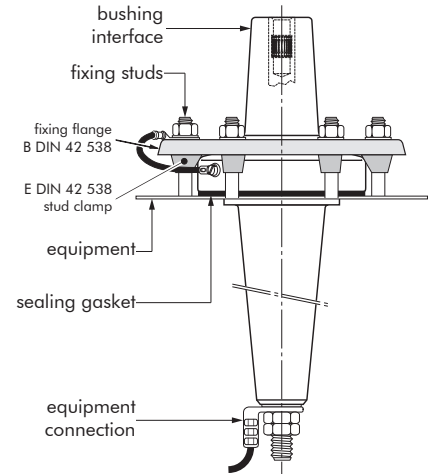
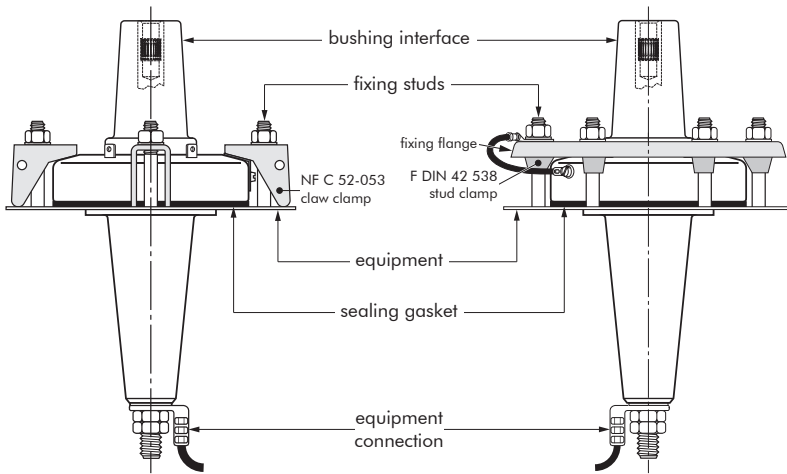

BUSHING CLAMPING KIT

To order the bushing clamping kit, according to NF C 52-053 standards, simply specify: KBC-NFC 52-053 /400 SERIES (for bushing type 400AR-2).
Contents: - 4 x claw clamp NF
- 1 x sealing gasket.

BUSHING CLAMPING KIT

To order the bushing clamping kit, simply specify: KBC-RING CLAMP 3.
Contents: - 1 x fixing flange
Ø150 mm
- 6 x stud clamp F
- 1 x sealing gasket.

BUSHING CLAMPING KIT

To order the bushing clamping kit, according to DIN 42 538 standards, simply specify: KBC - RING CLAMP 2.
Contents: - 1 x fixing flange B
- 6 x stud clamp E
- 1 x sealing gasket.

FIXING DIMENSIONS STANDARDS NF C 52-053

French standards.

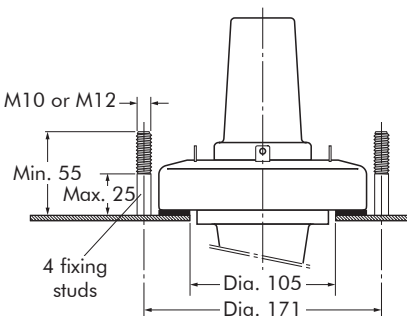

FIXING DIMENSIONS

French standards.

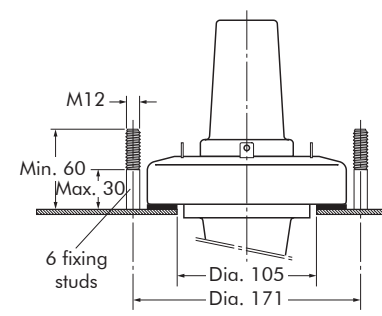

FIXING DIMENSIONS STANDARDS DIN 42 538

German standards.

