

APPLICATION

Separable tee shape connector (bolted type) designed to connect polymeric insulated cable to equipment (transformers, switchgear, motors, ...). Also connects cable to cable when using the appropriate mating parts.

TECHNICAL CHARACTERISTICS

- The thick conductive EPDM jacket provides a total safe to touch screen which ensures safety for personnel.
- Each separable connector is tested for AC withstand and partial discharge prior to leaving the factory.



DESIGN

Separable connector comprising:

1. Conductive EPDM insert.
2. Conductive EPDM jacket.
3. Insulating EPDM layer.
4. Type C interface as described by CENELEC EN 50180 and 50181.
5. Conductor contact.
6. Basic insulating plug (with VD point).
7. Cable reducer.
8. Conductive rubber cap.
9. Clamping screw.
10. Earthing lead.

The screen break design enables cable outer sheath testing without removing or dismantling the connector.

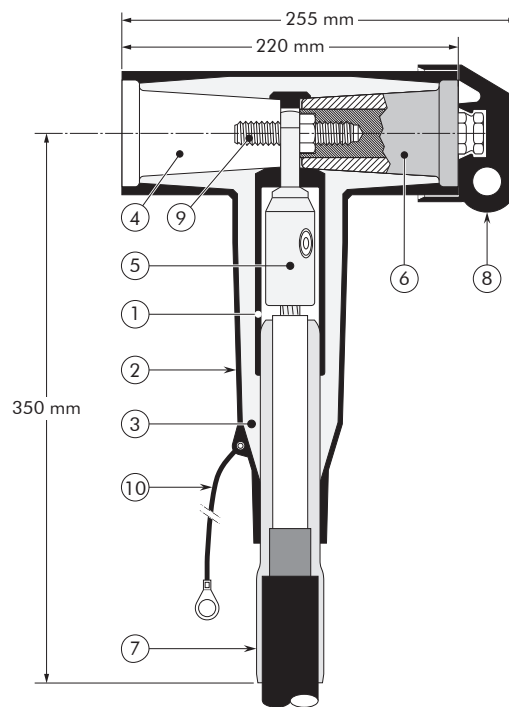

6/10 (12) kV
6.35/11 (12) kV
8.7/15 (17.5) kV
12/20 (24) kV
12.7/22 (24) kV
18/30 (36) kV
19/33 (36) kV
20.8/36 (42) kV

Up to 42 kV
630 A - 1250 A

EUROMOLD®

SPECIFICATIONS AND STANDARDS

The 400TB separable connector meets the requirements of CENELEC HD 629.1.

Separable connector type	Voltage U_m (kV)	Current I_r (A) When installed on C1 type bushing	Current I_r (A) When installed on C2 type bushing	Conductor sizes (mm ²)	
				min	max
400TB/G	12	630	1250	35	300
K400TB/G	24	630	1250	35	300
M400TB/G	36	630	1250	35	240
P400TB/G	42	630	1250	35	240

08/2021

KIT CONTENTS

The complete (K)(M)(P)400TB/G tee connector kit comprises the following components:

The kit also comprises silicone grease, gloves, wipers, roll adhesive tape and installation instructions.

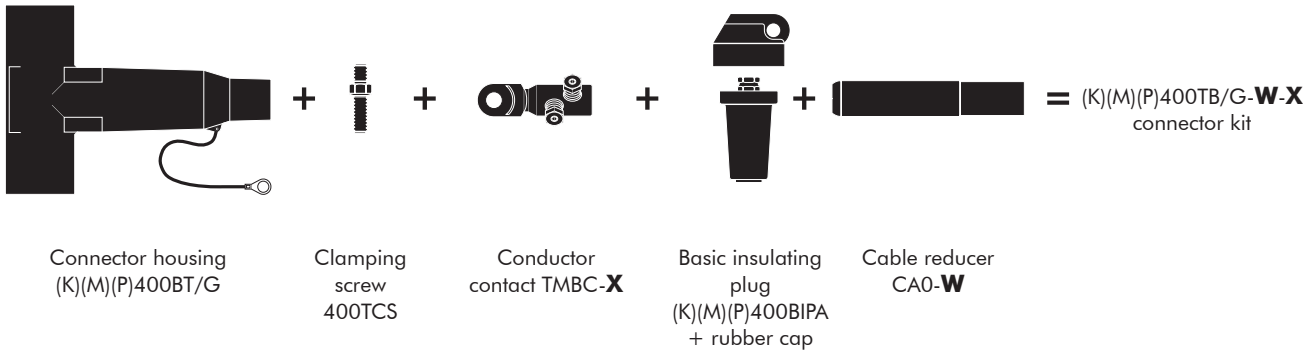

ORDERING INSTRUCTIONS

To order the tee connector, select the ordering part number which gives you the best centring of your core insulation diameter and substitute **X** using table X, according to your conductor size and type. Add a 'K' for use up to 24 kV, add an 'M' for use up to 36 kV, add a 'P' for use up to 42 kV.

EXAMPLE:

The cable is 24 kV, 185 mm² compact stranded copper with a diameter over core insulation of 27.5 mm. Order a 3 x K400TB/G-018-95.300UN5 tee connector kit.

TABLE W

Ordering part number	Dia. over core insulation (mm)	
	min	max
400TB/G-011-X	12.0	19.0
400TB/G-015-X	16.0	26.5
400TB/G-018-X	19.0	32.6
400TB/G-021-X	22.0	34.6
400TB/G-027-X	28.5	37.5

TABLE X

Conductor sizes (mm ²)	Aluminium and copper conductor	
	Bolted	
16	16.95UN5	
25		
35		
50		
70		
95	95.300UN5	
120		
150		
185		
240		
300		

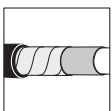

For use with copper tape screened cables. Order: Kit MT.

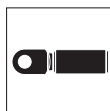

This product can also be installed using crimped conductor contacts. Please contact our representative.



For use with other cable types. Please contact our representative.



For applications outdoors and in humid climate. Order: +MWS.



For use in potentially explosive atmospheres (for 12 kV max). Order: ATEX-IECEx



Components can be ordered individually.