

Contents

Item	Page No.
Duct sealing systems	2
• FiloSeal+	3
• MDI	3
• MDII	3
• MDIII	9
• MDIV	11
• Fire resistant duct sealing	13
• Sealants	15

At Filoform, we focus on you - our customers. From the moment you contact us, you are assured of a friendly reception and a prompt response to your queries. We promise you our undivided attention and we will carry out your instructions to the letter.

Our dedicated, close knit and professional team will engage with you, to find out exactly what you want in order to supply you with the best solutions you need, in your specialized market sector. We also aim to continuously improve on our service to you, however we can, wherever we can.

We will act with openness, honesty and complete transparency in all of our dealings with you - in sales, production, research, administration and management.

Simply put, we want you to enjoy the best experience possible as a customer of Filoform.

Our Mission

As energy, communications and continuous innovation are all inextricably linked with our lives today, modern communication and utility networks will play a vital and increasingly important role in the creation of our future society.

Filoform's mission is to assist you in planning for this opportunity now and to provide you with the best solutions, applications and products to protect your investment in the future.



This future includes:

- The development of highly efficient and smart energy grids with which the end user has a relationship both as a buyer and seller of energy.
- The creation of decentralized energy production systems to meet local demand for electric mobility.
- The utilization of new, safer and sustainable energy sources like wind and solar power.
- Changing the way in which we work by planning and developing high data capacity fibre optic networks and different types of mobile communications networks.

Our Expertise

For over 50 years, we have developed major expertise in manufacturing and supplying quality products and solutions to connect, seal and protect the underground cable networks of our international and domestic customers.

Distributed by:

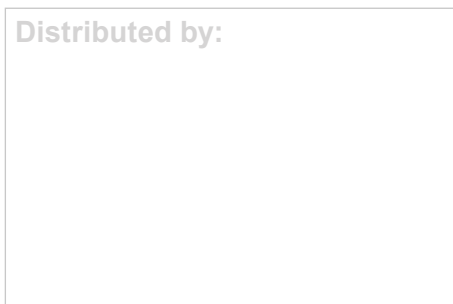

Head Office

Filoform BV

De Panoven 17
4191 GW Geldermalsen-NL
Netherlands

T: +31 (0) 345 58 82 20
F.: +31 (0) 345 52 82 21
E.: info@filoform.com
W.: www.filoform.nl

Filoform UK Ltd

Unit K Lambs Farm Business Park
Basingstoke Road, Swallowfield
Reading RG7 1PQ

T.: +44 (0) 1189 886873
F.: +44 (0) 1189 886576
E.: info@filoform.co.uk
W.: www.filoform.co.uk

ISO certification

The quality of our products is monitored - from raw material to the finished article. Our ISO 9001: 2008 certificate assures you that we work in accordance with specified procedures - from the development process and right through production. Because we review all of our processes on a constant basis, any deficiencies are noticed immediately. This ensures a continuous process of improvement.

This also applies to our environmental management system. Certified to ISO 14001: 2004, Filoform is committed to continuously improving on the environmental impact of our products and operations.

Quality, Environment, Health, and Safety Policy

Filoform works in a safe, responsible way, through which we respect quality, the environment and health of our employees, our clients and the community where we are active. We shall in no way act in a reckless way concerning values on quality, environment, health and safety in order to increase our profits or production.

Our products and working methods will be designed to respect all current laws and government directions. Our processes are as efficient as possible and we strive to continuously improve our products, services and customer satisfaction. Our education policy will enable employees to perform their tasks in the best possible way.

Filoform Values concerning Quality, Environment, Health and Safety:

- We value the human life above all and we deal accordingly with risks. We see this as a responsibility for all employees.
- We continuously strive to a work environment free of environmental, health and safety incidents. We see this as a responsibility for all employees.
- We make no concessions in our quality, environment, health and safety for profits or production. Where possible we will change to more environmental friendly solutions and products.
- We obey all laws and apply stricter rules to us and our vendors where we experience unacceptable risks.
- We support the durable development by considering social responsibility, economic success and high environmental quality in our decision making process.
- We measure and evaluate our impact on the environment and strive for continuously improvement.
- We deliver and use safe and reliable products and services.
- We use our knowledge on quality, environment, health and safety to improve the safety and well being in the community where we are active.
- We all have the obligation to respect and implement these principles and values. Each and every Filoform employee is expected to understand and promote this policy and the related principles and actively contribute to their implementation.



Duct sealing



Wherever a structure or facility needs connecting to necessary utilities, the fabric of the structure is breached by these connections. Often, these utilities enter via a duct system containing one or more cable or pipes.

Each duct entry to a structure is therefore a very easy way for contamination, infestations, floods and fire to enter! Filoform duct seals have been designed specifically to prevent this.

The Filoform range of duct sealing systems can:

- Protect from floods and dust contamination.
- Prevent the spread of gas through duct systems
- Prevent the spread of fire.
- Prevent the ingress by rodents and insects.
- Be selected very simply.

Selection of the best suited solution can be aided by calling your local sales office. Generally, the seals can be divided thus:

1. Semi-permanent seals (types MDI to MDIV), and

2. Re-openable seals (type Filoseal+)

The types MDI to MDIV are based upon a specifically formulated two component expanding polyurethane resin. The resin is packed in a divided transparent plastic bag with a screw point ready for the pouring nipple. By removing the divider and mixing for 30 seconds, the resin is ready to be poured into your MDI-IV seal system. After pouring, the resin starts to expand by forming CO₂. This expansion of the resin penetrates all areas inside the duct thus sealing any opening regardless of the shape of the duct or bore hole. Once expanded, the resin starts to cure and harden. The two component resin provides not only a 100% water and gas tight seal but also offers excellent mechanical strength.

The type Filoseal+ are based upon our MD+ silicon system. This system is particularly effective when there is a need to re-open the duct for removal or replacement of cables and pipes. The Filoseal+ kit comes with a two density foam filler piece to create a backing for the MD+ and create suitable cable or pipe spacing and retention. Once the foam filler piece is fitted into the duct (typically 20mm in) the one component MD+ silicon system is applied over the top using a standard mastic type skeleton gun. Once fully cured, the thixotropic MD+ forms a plastic elastomer mass with special qualities of sealing and bonding and also being very durable. Re-entry into the system is simple and fast and just requires more MD+ to be applied where it has been removed.



Fire



Flood



Rodents

FiloSeal+ Re-enterable Duct Sealing System

The Filoform duct sealing system FiloSeal+ uses our MD+ sealant which is easily applied from a skeleton gun. The high quality, one component, flexible sealant "MD+" is based on a silicon compound that cures with air (Humidity).

After application and full curing the thixotropic MD+ forms a plastic elastomer mass with special qualities effectively sealing and bonding, while providing a high level of durability.

FiloSeal+ is very easy to apply regardless of the type of cable scenario in the cable ducts as it uses a uniquely shaped foam piece which positions neatly around the cables or pipes in the duct.

The unique design of the tri-flexible foam makes positioning and separation of the cables very simple while also providing a backing for the MD+ to be applied on. This seal is easily installed in vertical scenarios while providing the added security of insuring no loss of components down the duct.

FiloSeal+ is suitable for sealing several cables or pipes contained in one duct and also allows re-entry of the seal to add or remove cables or pipes as required.

- Flexible, one component, adhesive and sealing compound in a cartridge - (310ml)
- High levels of Gas and Water tightness
- Excellent adhesion
- Shows Fire resistance properties
- Resistant to, Petrol, Diesel, Ethanol, ASTM oil, LPG & Many more.
- Resistant against Water, Alkaline, Chemical agents
- Resistant to Hydrogen Sulphide / Methane and many other Gases (NedLab)
- Non corrosive
- Solvent free
- Shock absorbing
- Non toxic, neutral and almost odourless
- Complies with ATEX regulations
- WIMES Compliant, (3.02 clause 7.4.3.2, d & e)
- Suitable for any shaped duct / bore hole / opening
- Quick and easy installation
- A complete kit for one duct
- Seals all know materials, PVC & PE sheathed cables, PILC, (HD) PE pipes
- Suitable for renovations, can be installed retrospectively
- Over 25 years of operational experience

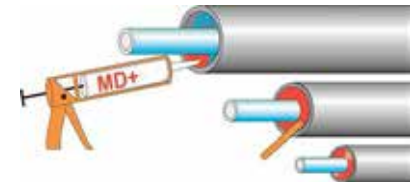
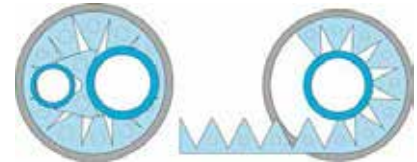

Item number	Description	Maximum duct diameter (mm)	Maximum cable / pipe diameter in the duct (mm)	Order unit
80203	FiloSeal+ 50mm	max. Ø 50	max. Ø 40	per piece
80201 / 282580	FiloSeal+ 125mm	max. Ø 125	max. Ø 95	per piece
80202 / 282590	FiloSeal+ 200mm	max. Ø 200	max. Ø 160	per piece



FiloSeal+ Re-enterable Duct Sealing System

Specifications

Density	1,2 gr/cm ³	
Flow	< 2mm	ISO 7390
Colour	red-brown	
Skin over time (23C/55%RH)	± 15 minutes	
Curing	1,5mm / 24 hours	
Hardness	30 shore A	DIN 53505
Elongation	100%	DIN 53504
Tensile strength	0,8 N/mm ²	DIN 53504
Operating temperature	+5°C tot +40°C	
Temperature resistance	-40°C tot +120°C	

FiloSeal+ < 50mm art.nr 80203



*The FiloSeal+ < 50mm kit can be used for up to 10 ductsealings

FiloSeal+ < 125mm art.nr 80201 / part no 282580



FiloSeal+ 125mm - 200mm art.nr 80202 / part no 282590

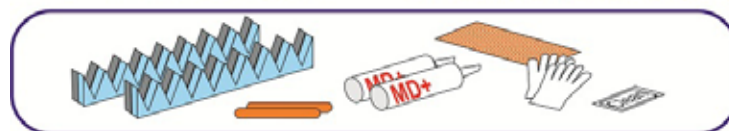

Item number	Description	Order unit
282595	Finishing Sponge	per piece

FiloSeal+ Re-enterable Duct Sealing System

One of the reasons why ducts are sealed is to prevent running water getting into a building or enclosure. Often when faced with sealing a duct, this running water is still evident.

Our FiloSeal Running Water Block system provides the user with a method of preventing the water from ruining any permanent sealing system whilst that system is installed. The kit provides a method of damming the water flow, controlling it and stopping it.

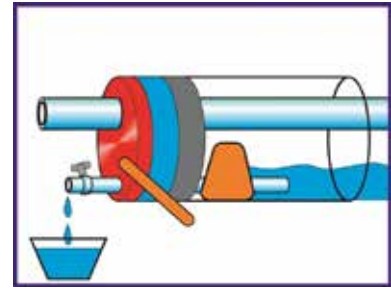

Small kit

- Non-hardening plastic waterproofing sealant.(Damming Putty)
- 200mm length 15mm pipe
- 15mm Emergency tap
- Pipe insert to strengthen pipe when tap is fitted

Large kit

- Non-hardening plastic waterproofing sealant.(Damming Putty) x 2
- 200mm length 15mm pipe
- 15mm Emergency tap
- Pipe insert to strengthen pipe when tap is fitted

Properties	Unit	Nominal Value
Dielectric Strength	kV / mm	13,5
Dielectric constant (K)		6.5
Volume Resistivity at 20°C	Ohm.m	8 x 10 ¹¹
Temperature range	°C	-20 to +80
Working voltage (maximum)	kV	1
Specific gravity at 15.5°C		1.70
Flashpoint	°C	+210

Item number	Description	Order unit
282592	Small Running Water Block kit	per piece
282593	Large Running Water Block kit	per piece

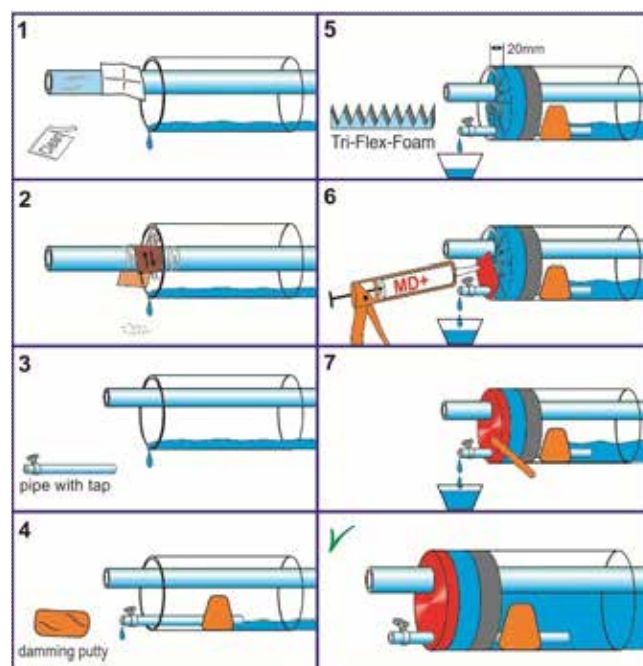

MDI - Duct sealing system

Duct sealing system MD I has been developed for sealing ducts containing pliable cables such as coax and rubberised cables, which can be easily bent to a right angle.

This system allows these usually vulnerable cables to be sealed anywhere along a wall where the cable enters a building

Suitable for ducts with a diameter of 16mm up to 32mm and cables or pipes with a diameter up to 25mm. All our duct sealing system is specified and used by major Electrical, Gas, & Water Utility companies in the UK and Benelux countries.



Properties	Unit	Value
Start time expansion	seconds	> 95
End time expansion	minutes	15
Compressive strength	N / cm ²	> 100
Density 0,5bar	30 days	no leakage
Density 5m water column	30 days	no leakage
Volume consistency	cube 10 x 10cm	no change
Temperature Cycles, -20°C tot +40°C	10 consecutive cycles	no leakage
Vibration test 10 Hz/amplitude 3mm	240 hours	no leakage
Axial tensile force	diameter x 10 N	no leakage
Resistance to bending	cables 45° in 2 directions >250mm	no leakage
Expansion polyurethane foam in pipe	cm	< 40
Chemical resistance		
0,1N Na ₂ SO ₄	30 days	no degradation
0,1N NaCl	30 days	no degradation
0,1N H ₂ SO ₄	30 days	no degradation
0,1N NaOH	30 days	no degradation
Diesel	30 days	no degradation
Gasoline	30 days	no degradation
Resistance		
Moulds		good
Rodents		good
Shelf life	months	minimal 30

Item number	Description	Maximum duct diameter (mm)	Maximum cable diameter in the duct (mm)	Order unit
280220	MDI-1 25mm duct sealing kit	Ø 16 - 32	max. Ø 12.5	per piece
280223P	MDI-2 50mm duct sealing kit	Ø 32 - 60	max. Ø 25	per piece



MDII - Duct sealing system

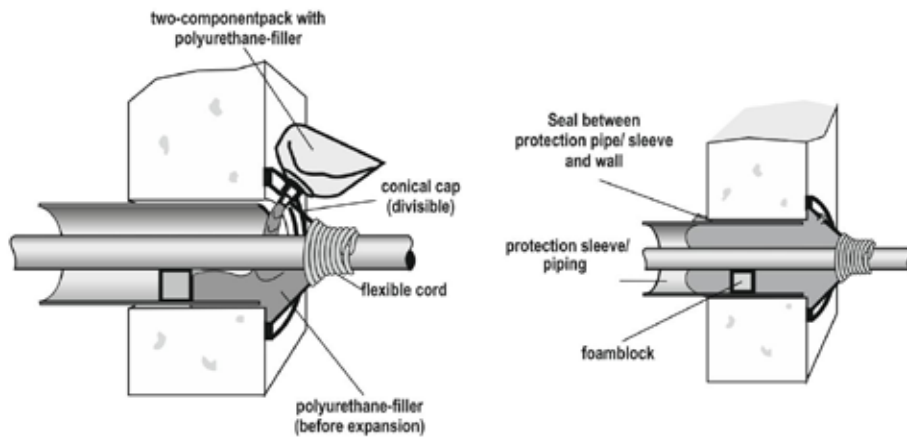

Duct sealing system type MDII has been developed to provide an effective and simple solution to all gas- and watertight duct sealing requirements. MDII will not only seal the space between the cable or pipe but also the space between the duct and the wall in one operation.

The MDII system is suitable in situations where more than one cable or pipe is in the duct. The opening of the duct does not need to be completely round.

Seals all known materials: PVC & PE sheeted cables, PILC cables, (HD)PE pipes, PE drinking water conduits.

Due to the design of the divisible conical cap, it is possible to install the system also in existing situations. Installation of the cap can be done by trimming the cap to the desired diameter of the cable or pipe.

Product overview

Item number	Description	Maximum duct diameter (mm)	Maximum cable diameter in the duct (mm)	Order unit
280271P	MDII-50 duct sealing kit	max. Ø 50	max. Ø 40	per piece
280261	MDII-110 duct sealing kit	max. Ø 110	max. Ø 70	per piece
280251	MDII-125 duct sealing kit	max. Ø 125	max. Ø 90	per piece
280241	MDII-160 duct sealing kit	max. Ø 160	max. Ø 130	per piece
280246	MDII-200 duct sealing kit	max. Ø 200	max. Ø 160	per piece
280247	MDII-250 duct sealing kit	max. Ø 250	max. Ø 200	per piece



Set Contents

- Conical cap with sealing cap
- Foam support block
- Self-adhesive foam strip
- Flexible cord
- Expanding polyurethane filler
- Screw nipple
- Set protective gloves
- Sandpaper



MDII - Duct sealing system

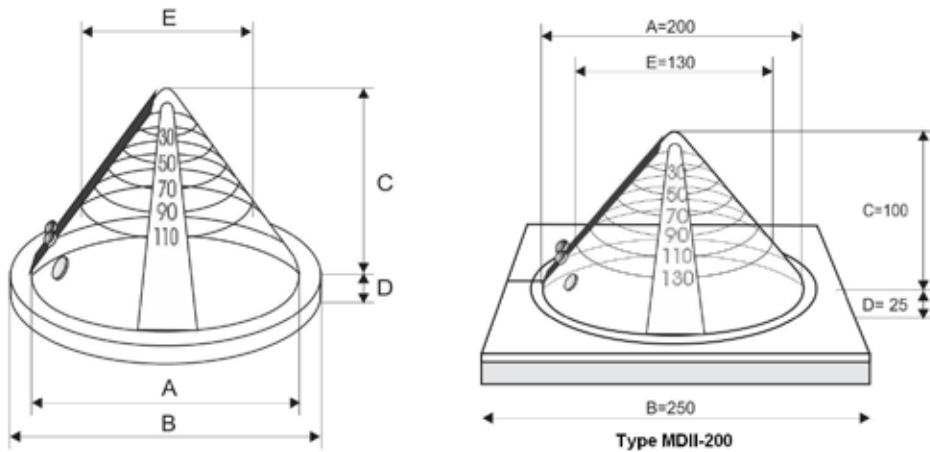

	MDII-50	MDII-110	MDII-125	MDII-160	MDII-200	MDII-250
A	80	130	150	200	200	300
B	100	150	170	220	250	350
C	80	75	70	90	160	130
D	16	15	15	15	25	25
E	40	70	90	130	160	250

Specifications

Properties	Unit	Value
Start time expansion	seconds	> 95
End time expansion	minutes	15
Compressive strength	N / cm ²	> 100
Gas and water tightness 1,0bar	30 days	no leakage
Density 10m water column	30 days	no leakage
Volume consistency	cube 10 x 10cm	no change
Temperature Cycles, -20°C tot +40°C	10 consecutive cycles	no leakage
Vibration test 10 Hz/amplitude 3mm	240 hours	no leakage
Axial tensile force	diameter x 10 N	no leakage
Resistance to bending	cables 45° in 2 directions >250mm	no leakage
Expansion polyurethane foam in pipe	cm	< 40
Chemical resistance		
0,1N Na ₂ SO ₄	30 days	no degradation
0,1N NaCl	30 days	no degradation
0,1N H ₂ SO ₄	30 days	no degradation
0,1N NaOH	30 days	no degradation
Diesel	30 days	no degradation
Gasoline	30 days	no degradation
Resistance		
Moulds		good
Rodents		good
Shelf life	months	minimal 30

Installation Video
filoform.com/en/video



MDIII - Duct sealing system



Duct sealing system type MD III is designed for sealing cable and pipe penetrations in conduits or duct openings that are tightly positioned against each other.

The MDIII systems has two circular foam flanges that creates a chamber where our specially formulated expanding polyurethane resin can easily be injected due to the convenient and safe to use twin pack with screw nipple and filling tube. The polyurethane resin will expand and thus create a gas and watertight seal.



Item number	Description	Maximum duct diameter (mm)	Maximum cable diameter in the duct (mm)	Order unit
780291	MDIII-25 duct sealing kit	max. Ø 25	max. Ø 8	per piece
282550	MDIII-50 duct sealing kit	max. Ø 50	max. Ø 20	per piece
282575	MDIII-75 duct sealing kit	max. Ø 75	max. Ø 40	per piece
280295	MDIII-110 duct sealing kit	max. Ø 110	max. Ø 80	per piece
280296	MDIII-160 duct sealing kit	max. Ø 160	max. Ø 130	per piece
2802973	MDIII-200 duct sealing kit	max. Ø 200	max. Ø 160	per piece
2802978	MDIII-250 duct sealing kit	max. Ø 250	max. Ø 220	per piece

Set Contents

- 2 foam flanges
- Self-adhesive foam strips
- Expanding polyurethane filler
- Screw nipple with filling tube
- Set protective gloves
- Sandpaper
- Installation instructions

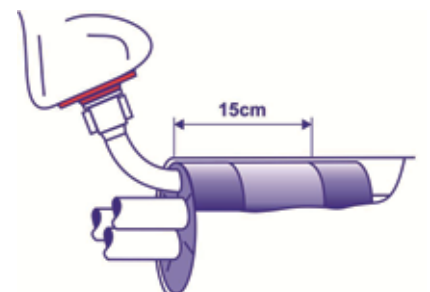
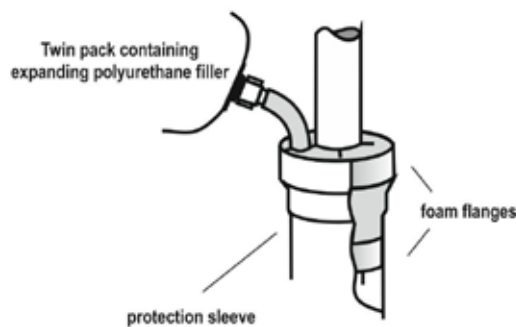

MDIII - Duct sealing system

Specifications

Properties	Unit	Value
Start time expansion	seconds	> 95
End time expansion	minutes	15
Compressive strength	N / cm ²	> 100
Gas and water tightness 1,0bar	30 days	no leakage
Density 10m water column	30 days	no leakage
Volume consistency	cube 10 x 10cm	no change
Temperature Cycles, -20°C tot +40°C	10 consecutive cycles	no leakage
Vibration test 10 Hz/amplitude 3mm	240 hours	no leakage
Axial tensile force	diameter x 10 N	no leakage
Resistance to bending	cables 45° in 2 directions >250mm	no leakage
Expansion polyurethane foam in pipe	cm	< 40
Chemical resistance		
0,1N Na ₂ SO ₄	30 days	no degradation
0,1N NaCl	30 days	no degradation
0,1N H ₂ SO ₄	30 days	no degradation
0,1N NaOH	30 days	no degradation
Diesel	30 days	no degradation
Gasoline	30 days	no degradation
Resistance		
Moulds		good
Rodents		good
Shelf life	months	minimal 30

Installation Video

filoform.com/en/video

MDIV - Duct sealing system

Sealing system type MDIV has been developed to create an effective gas and watertight seal of ducts that have no cables or pipes installed.

The sealing system type MDIV consists of a foam ended hollow clear tube, and a safe to use twin pack containing our specially formulated expanding polyurethane filler.

This polyurethane filler is injected in the centre of the hollow tube, which then the seal needs to be pushed and positioned in the duct / bore hole. The polyurethane filler will expand thus sealing the duct against water and gas.

If the duct needs to be utilised at a later date then the MDIV can be removed easily by using a sharp cutting tool. The duct can then be re-sealed by using either of our sealing systems.

The sealing system MDIV can also be used for sealing vertical ducts.

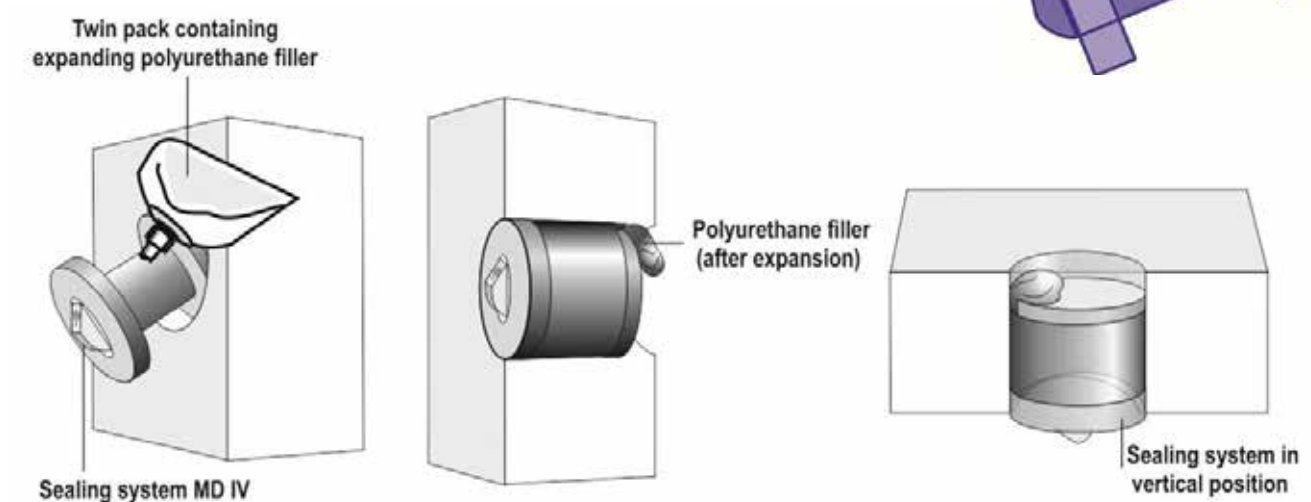

Item number	Description	Maximum duct diameter (mm)	Maximum cable diameter in the duct (mm)	Order unit
280301	MDIV-1 Ø 75- 95	Ø 75 - 95	N/A	per piece
280321	MDIV-3 Ø 95- 125	Ø 95 - 125	N/A	per piece
280331P	MDIV-4 Ø 125- 160	Ø 125 - 160	N/A	per piece

Set Contents

- Coil shaped unit
- Expanding polyurethane filler
- Screw nipple
- Set protective gloves
- Sandpaper
- Installation instruction



MDIV - Duct sealing system

Specifications

Properties	Unit	Value
Start time expansion	seconds	> 95
End time expansion	minutes	15
Compressive strength	N / cm ²	> 100
Gas and water tightness 1,0bar	30 days	no leakage
Density 10m water column	30 days	no leakage
Volume consistency	cube 10 x 10cm	no change
Temperature Cycles, -20°C tot +40°C	10 consecutive cycles	no leakage
Vibration test 10 Hz/amplitude 3mm	240 hours	no leakage
Axial tensile force	diameter x 10 N	no leakage
Expansion polyurethane foam in pipe	cm	< 40
Chemical resistance		
0,1N Na ₂ SO ₄	30 days	no degradation
0,1N NaCl	30 days	no degradation
0,1N H ₂ SO ₄	30 days	no degradation
0,1N NaOH	30 days	no degradation
Diesel	30 days	no degradation
Gasoline	30 days	no degradation
Resistance		
Moulds		good
Rodents		good
Shelf life	months	minimal 30

Installation Video

filoform.com/en/video

MD+ Fire Resistant sealants for ducts

The effective, and easy to install solution to gas, watertight, and fire proof duct sealing requirements.

Introduction

Filoform duct Sealing systems have been used for decades to provide a gas and watertight sealing. The seals can also be made fire resistant for up to 2 hours by using a special fire resistant sealant.

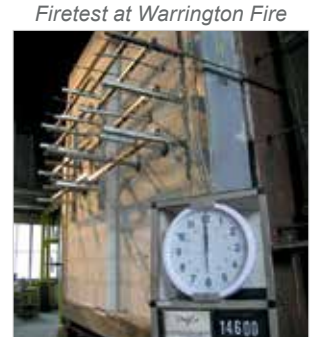

Gas- and watertight

Filoform duct sealing systems are based on a specially formulated expanding 2-component polyurethane resin. The resin is packed in a transparent twin pack already prepared for use with a filling nozzle. After removing the separation strip, the 2 components should be thoroughly mixed for 30 seconds. Once the resin is ready for use; the twin pack is easily opened by installing the screw type filling nozzle. Once the resin has been squeezed into the duct it expands due to the formation of CO₂. During this expansion process the resin penetrates into any gaps regardless of the shape, size, number of cables or tubes that is installed. The expanded resin will cure and form a durable gas and watertight seal with excellent mechanical strength.

Fire resistant

Using the special MD+ Fire Resistant Sealant in combination with Filoform/MD-Duct Sealing Systems provides fire resistance up to 2 hours in conformity with the standard EN1366-3:2009*.

Filoform duct sealing systems are easily adjusted to the requirements of any specific situation.

**Fire resistance in conformity with the standard EN1366-3:2009 can only be achieved when the duct seal is installed in accordance with our installation instructions. The fire resistance in conformity with the standard EN1366-3:2009 has been tested and approved by Warrington fire.*

Benefits

- High levels of gas and water tightness
- Fire resistance up to 2 hours (see page 7 for details)
- Fire resistance tested on various types of cables and piping
- Suitable for use with all shapes, size / diameter of ducts
- Quick & easy installation
- A complete kit for one duct
- Suitable for all cable and pipe materials
- Excellent mechanical strength, (after curing) resistant to movement, shocks and vibrations
- Suitable for renovations, can be installed retrospectively
- Over 25 years of operational experience in the field

Fire resistant up to 2 hours!

Classifications

Filoform had a large number of different penetration configurations tested in accordance with the standard EN1366-3:2009, and had these classified in accordance with the standard EN13501-2: 2007 +A1: 2009. Based on this, the Filoform duct seals, provided installed as described above, have been classified as follows:

Penetration seals with cables:

- MDII in combination with MD+ fire resistant sealant: 90 minutes (EI 90, E 90)
- MDIII in combination with MD+ fire resistant sealant: 120 minutes (EI 120, E 120)

Penetration seals with steel pipe (for example gas pipe):

- MDII & MDIII in combination with MD+ fire resistant sealant: 90 minutes (EI 90-C/U, E 90 C/U)

Seals without cables or pipes:

- MDIV in combination with MD+ fire resistant sealant: 120 minutes (EI 120, E 120)

MD+ Fire Resistant sealants for ducts



Application

The high quality MD+ Sealant is a fire resistant and flexible one-component product.

This fire resistant sealing compound is based on a silicon combination. After application, the thixotropic compound cures with atmospheric moisture to form a durable seal. MD+ is also suitable to provide a fire resistant finish to the Filoform MD-series duct sealing systems, if applied as follows:

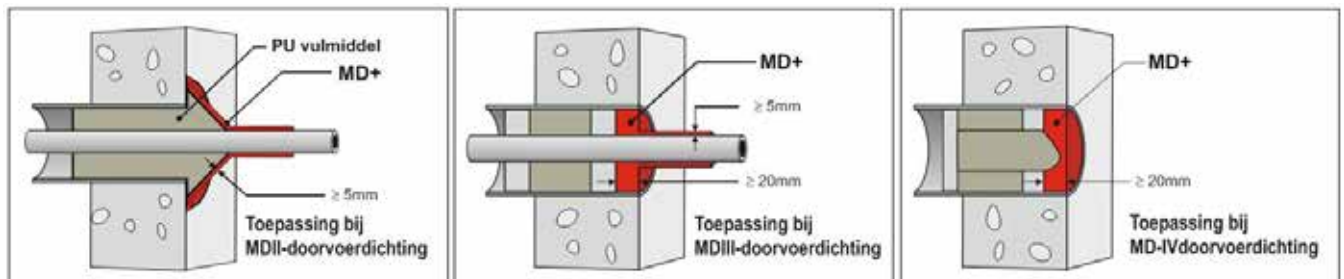

Characteristics

- Flexible, one-component, adhesive and sealing compound in cartridge (310 ml.)
- Gastight and watertight seal
- Fire resistant
- Tested on various cable- and piping types
- Excellent adhesion
- Good resistance against water, alkaline, chemical agents, oil and greases
- Non corrosive
- Solvent free
- Shock absorbing
- Safe useage; non-toxic, neutral and almost odourless.

Fire resistant	until 2 hours depending on application	
Density	1,2 gr/cm ³	
Flow	< 2mm	ISO 7390
Color	red-brown	
Skin over time (23C/55%RH)	± 15 minutes	23°C/55%RH
Curing	1,5 mm/24 hours	
Hardness	30 shore A	DIN 53505
Elongation	100%	DIN 53504
Tensile strength	0,8 N/mm ²	DIN 53504
Operating temperature	+5°C to +40°C	
Temperature resistance	-40°C to +120°C	

Item number	Description	Order unit
80849	MD+ fire resistant sealant kit 310ml	12 pcs/carton

Fill & Seal sealing kit 290ml

Filoform Fill & Seal compound is a high quality, flexible and strong one-component product. The Filoform glueing and sealing compound is based on a hybrid MS-polymer.

After application the compound cures with atmospheric moisture to form a durable, high-levelled elastomer. Applications for Fill & Seal compound are telecom technique, cable ducts, wall ducts, gastight and watertight sealing for centre plugs and duct plugs. Also used as a glueing and sealing compound in construction and shipbuilding industry.

Item number	Description	Order unit
80840	Fill & Seal sealing kit 290ml	12 pcs/carton



Technical specifications		
Density	1,4 gr/cm ³	
Thixotropic	good	
Colour	white	
Skin hardening	± 10 minutes	
Hardening	3mm / 24 hours	
Hardness	55 shore A	DIN 53504
Elongation	250%	DIN 53504
Tensile strength	1,7 N/mm	DIN 53504
Volume change	< 3%	DIN 52451
Shear strength	2,5 N/mm ²	
Operating temperature	+5°C till +40°C	
Temperature resistance	-40°C till +120°C	



connect ▶ seal ▶ protect ▶