

REVISION HISTORY	
1	Original Concept

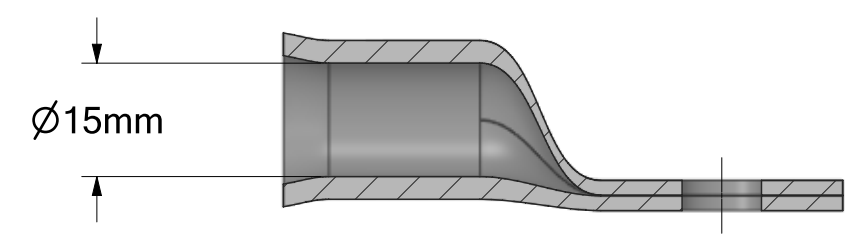

SECTION A-A

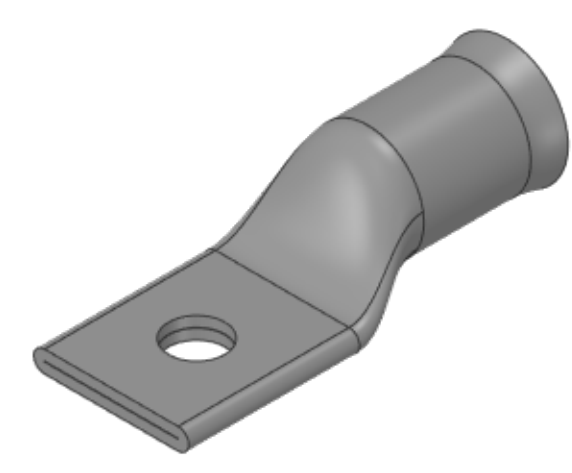
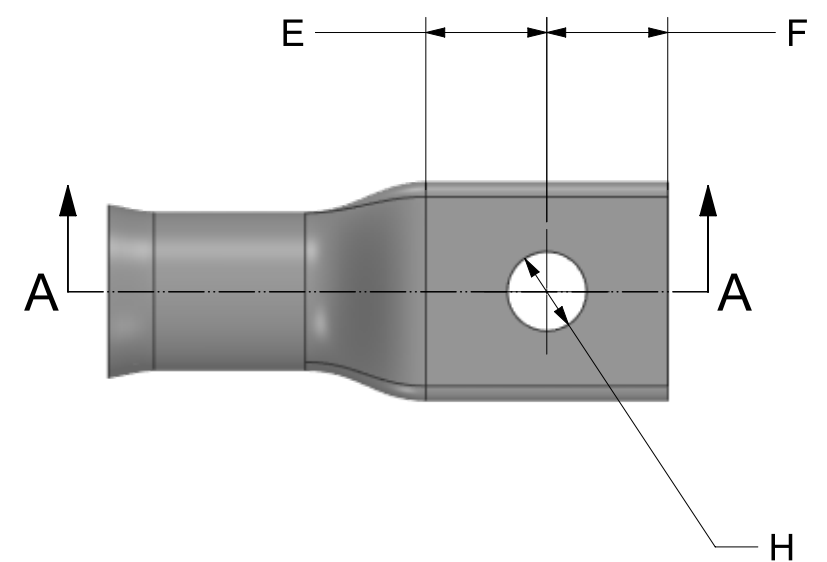
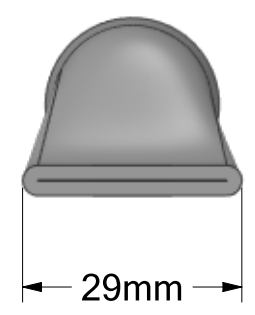

PART NO.	H (mm)	E (mm)	F (mm)
TCS1-120-0	0	N/A	32.0
TCS1-120-6	6.5	16.0	16.0
TCS1-120-8	8.5	16.0	16.0
TCS1-120-10	10.5	16.0	16.0
TCS1-120-12	13.0	16.0	16.0

UOS - LINEAR TOLERANCE PERMISSABLE DEVIATIONS FOR SIZE RANGE:  
Tolerances according to DIN ISO 2768 (V)

DIMS IN MM	0.5 to 3	>3 to 6	>6 to 30	>30 to 120	>120 to 400	>400 to 1000	>1000 to 2000	>2000 to 4000
	-	±0.5	±1.0	±1.5	±2.5	±4.0	±6.0	±8.0

Drawing No. TCDR2056

Material. SS 316L

Part No. TCS1-120-RANGE

Finish. N/A

SIZE A3  
Date 17/05/2021

Created By:  
Dan Hewlett

REV 1

SCALE 1:1

SHEET 1 of 1