

REVISION HISTORY	
1	Original Concept

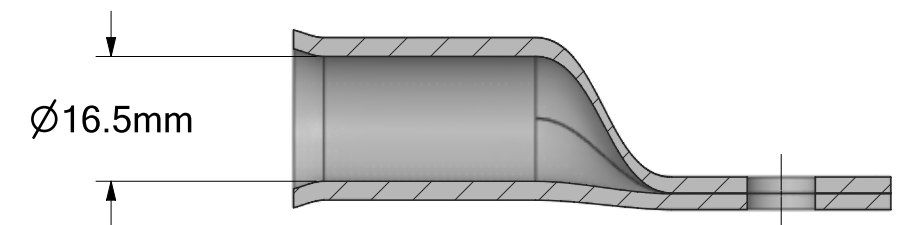

SECTION A-A

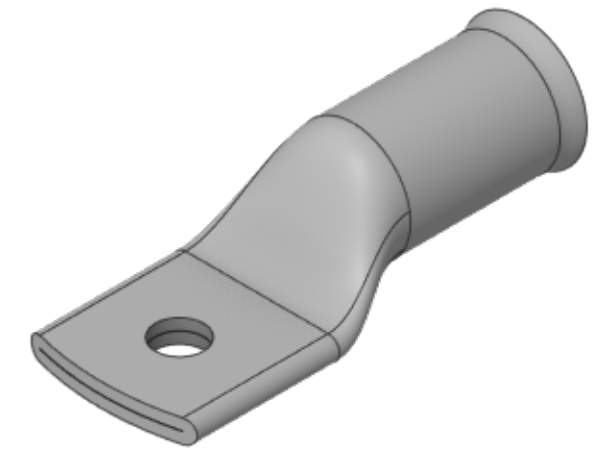
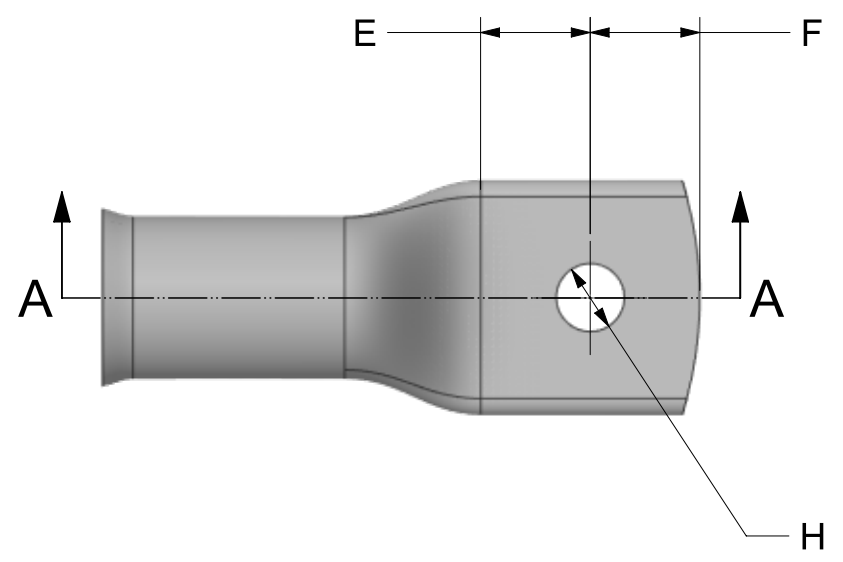
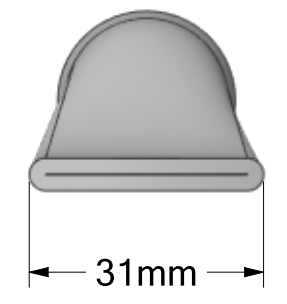

PART NO.	H (mm)	E (mm)	F (mm)
TCS1-150-0	N/A	N/A	29.0
TCS1-150-6	6.5	14.5	14.5
TCS1-150-8	8.5	14.5	14.5
TCS1-150-10	11.0	14.5	14.5
TCS1-150-12	13.0	14.5	14.5
TCS1-150-14	14.5	14.5	14.5
TCS1-150-16	16.5	14.5	14.5

UOS - LINEAR TOLERANCE PERMISSABLE DEVIATIONS FOR SIZE RANGE:
Tolerances according to DIN ISO 2768 (V)

DIMS IN MM	0.5 to 3	>3 to 6	>6 to 30	>30 to 120	>120 to 400	>400 to 1000	>1000 to 2000	>2000 to 4000
	-	±0.5	±1.0	±1.5	±2.5	±4.0	±6.0	±8.0

Drawing No. TCDR 2072		Material. SS316L	
Part No. TCS1-150-RANGE		Finish. N/A	
SIZE A3	Date 04/06/2021	Created By: Dan Hewlett	REV 1
SCALE 1:1		SHEET 1 of 1	