

REVISION HISTORY	
1	Original Concept
2	Missing dimensional details added
3	Extra column added to table (W)

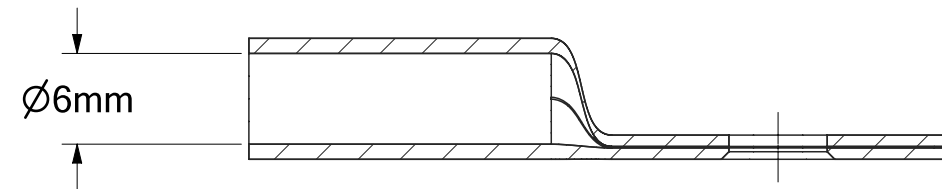

SECTION A-A

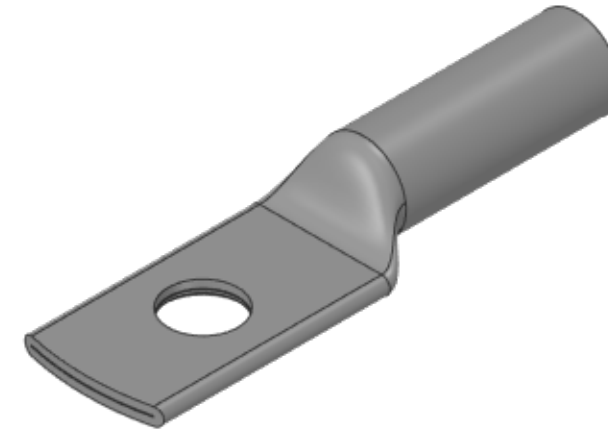
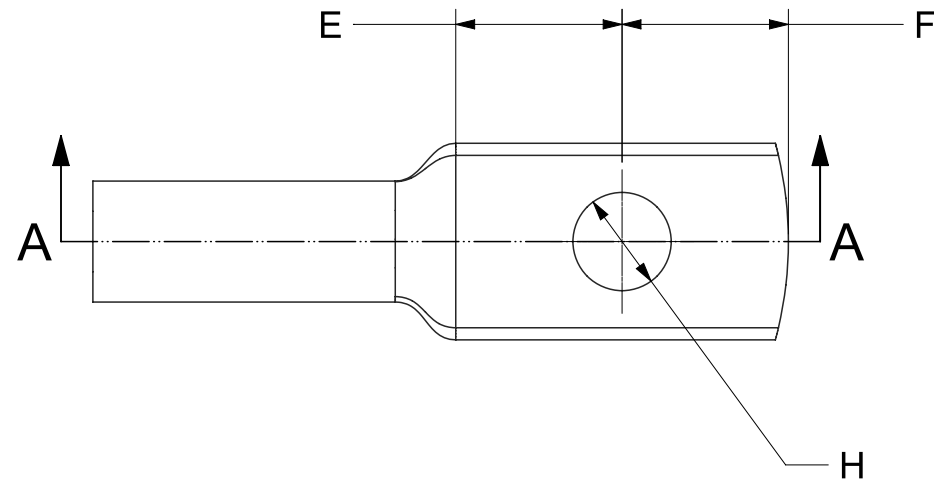
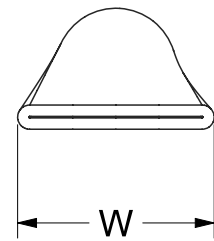

PART NO.	H (mm)	E (mm)	F (mm)	W (mm)
TCS1-16-5	5.5	11.0	11.0	13.0
TCS1-16-6	6.5	11.0	11.0	13.0
TCS1-16-8	8.5	11.0	11.0	13.0
TCS1-16-10	10.5	11.0	11.0	13.0
TCS1-16-12	13.0	11.0	11.0	18.0

UOS - LINEAR TOLERANCE PERMISSABLE DEVIATIONS FOR SIZE RANGE:
Tolerances according to DIN ISO 2768 (V)

DIMS IN MM	0.5 to 3	>3 to 6	>6 to 30	>30 to 120	>120 to 400	>400 to 1000	>1000 to 2000	>2000 to 4000
	-	±0.5	±1.0	±1.5	±2.5	±4.0	±6.0	±8.0

Drawing No. TCDR 2039

Material. SS316L

Part No. TCS1-16-RANGE

Finish. N/A

SIZE A3
Date 10/05/2021

Created By:
Dan Hewlett

REV 3

SCALE 2:1

SHEET 1 of 1