

REVISION HISTORY	
1	Original Part
2	Table dimension updates

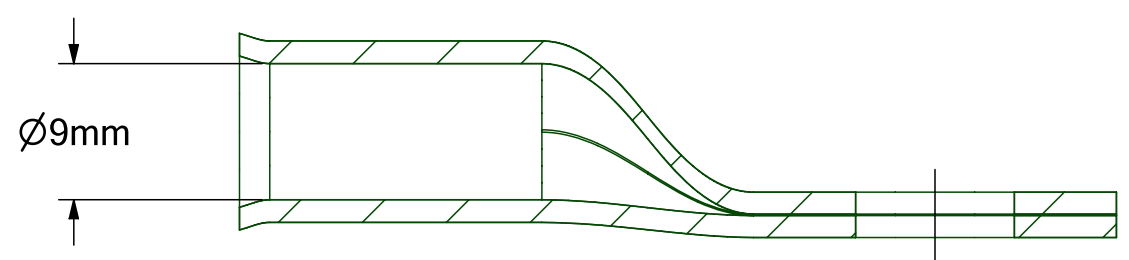

SECTION A-A

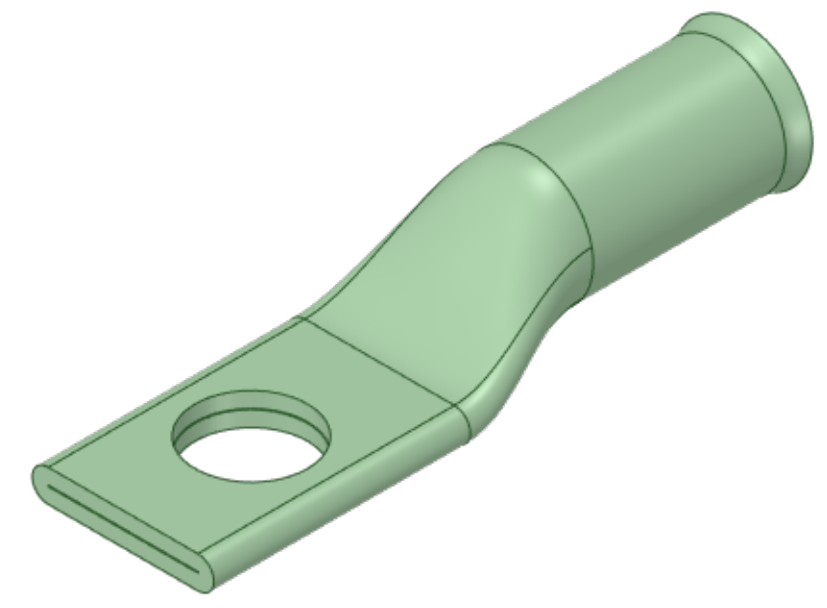
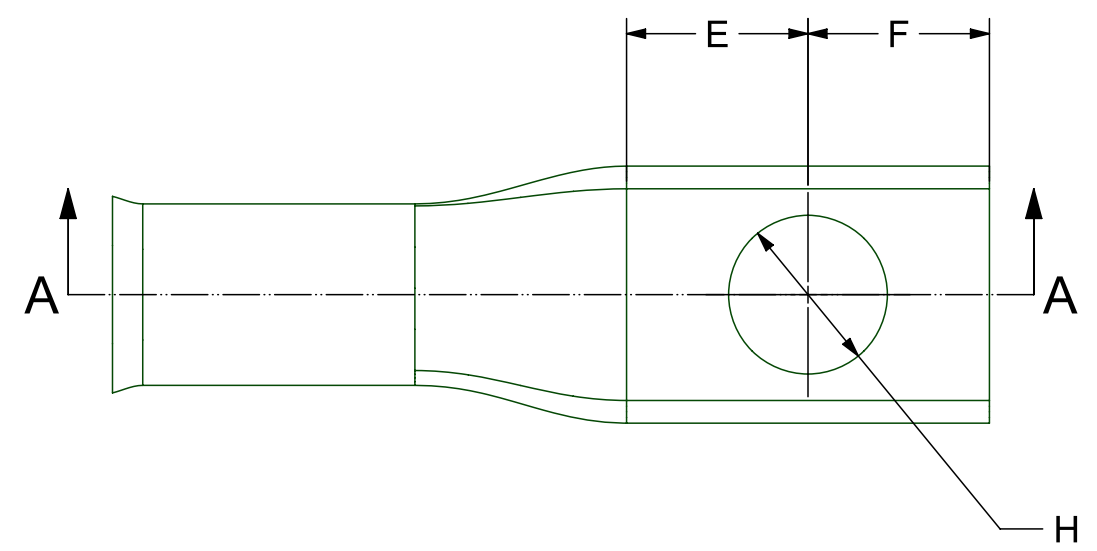
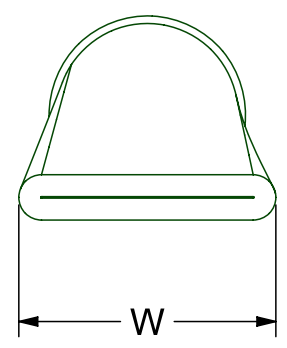

PART NO.	H (mm)	E (mm)	F (mm)	W (mm)
TCS1-35-0	0	N/A	24.0	17.0
TCS1-35-6	6.5	12.0	12.0	17.0
TCS1-35-8	8.5	12.0	12.0	17.0
TCS1-35-10	10.5	12.0	12.0	17.0
TCS1-35-12	13.0	12.0	12.0	19.0
TCS1-35-14	14.5	12.0	12.0	20.0

UOS - LINEAR TOLERANCE PERMISSIBLE DEVIATIONS FOR SIZE RANGE:  
Tolerances according to DIN ISO 2768 (V)

DIMS IN MM	0.5 to 3	>3 to 6	>6 to 30	>30 to 120	>120 to 400	>400 to 1000	>1000 to 2000	>2000 to 4000
	-	±0.5	±1.0	±1.5	±2.5	±4.0	±6.0	±8.0

Drawing No. TCDR1944		Material. SS316L	
Part No. TCS1-35-RANGE		Finish. N/A	
SIZE A3	Date 25/03/2021	Created By: Dan Hewlett	REV 2
SCALE 2:1			SHEET 1 of 1