

REVISION HISTORY	
1	Original Part
2	Hole dimension adjustment

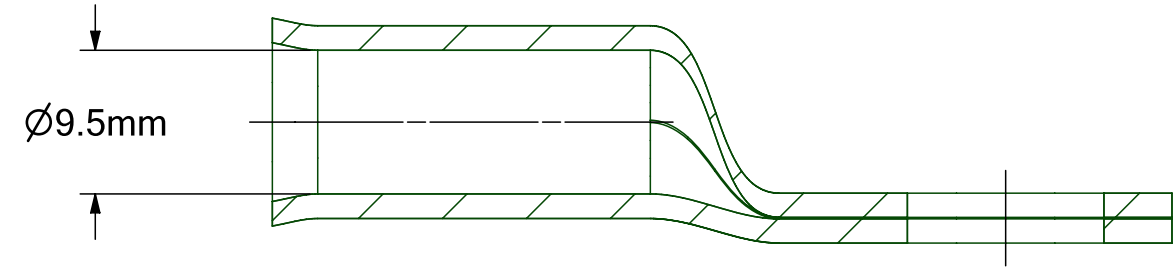

SECTION A-A

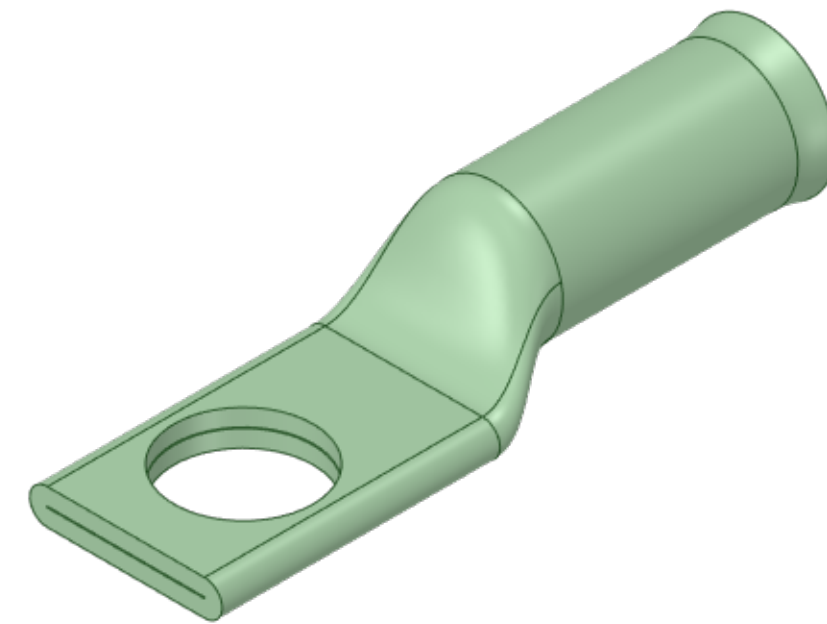
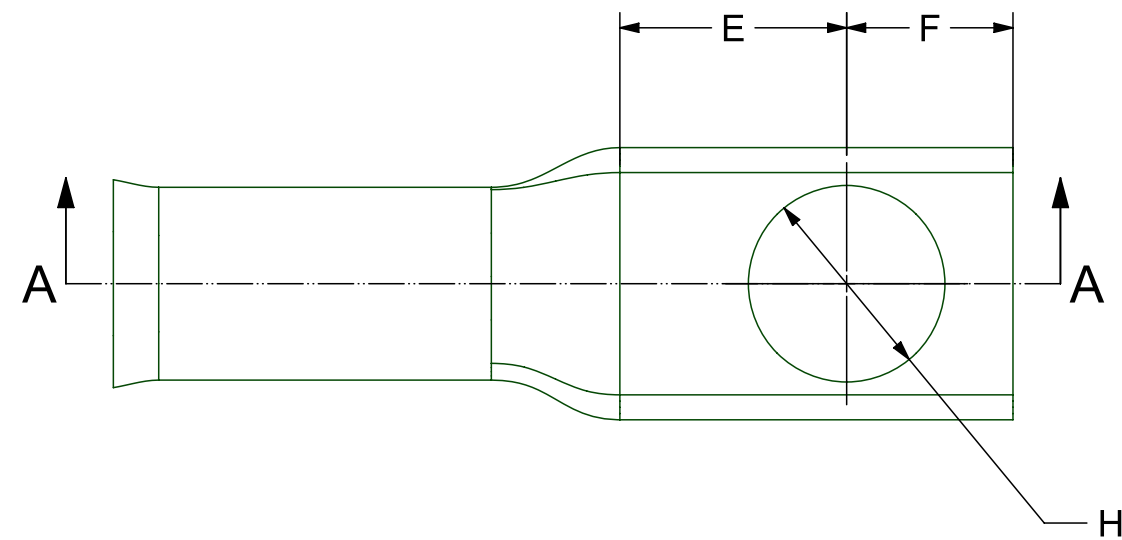
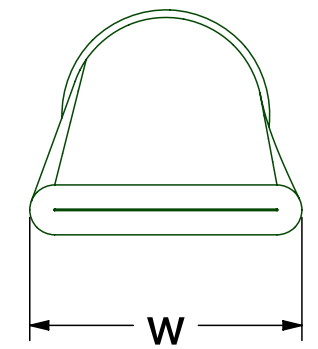

PART NO.	H (mm)	E (mm)	F (mm)	W (mm)
TCS1-50s-0	0	N/A	26.0	18.0
TCS1-50s-6	6.5	14.0	12.0	18.0
TCS1-50s-8	8.5	14.0	12.0	18.0
TCS1-50s-10	10.5	14.0	12.0	18.0
TCS1-50s-12	13.0	14.0	12.0	18.0

UOS - LINEAR TOLERANCE PERMISSABLE DEVIATIONS FOR SIZE RANGE:
Tolerances according to DIN ISO 2768 (V)

DIMS IN MM	0.5 to 3	>3 to 6	>6 to 30	>30 to 120	>120 to 400	>400 to 1000	>1000 to 2000	>2000 to 4000
	-	±0.5	±1.0	±1.5	±2.5	±4.0	±6.0	±8.0

Drawing No. TCDR 1937 Material. SS316L

Part No.TCS1-50s-RANGE Finish. N/A

SIZE A3 Date 24/03/2021 Created By: Dan Hewlett REV 2

SCALE 2:1 SHEET 1 of 1