

REVISION HISTORY	
1	Original Concept
2	Dimension update

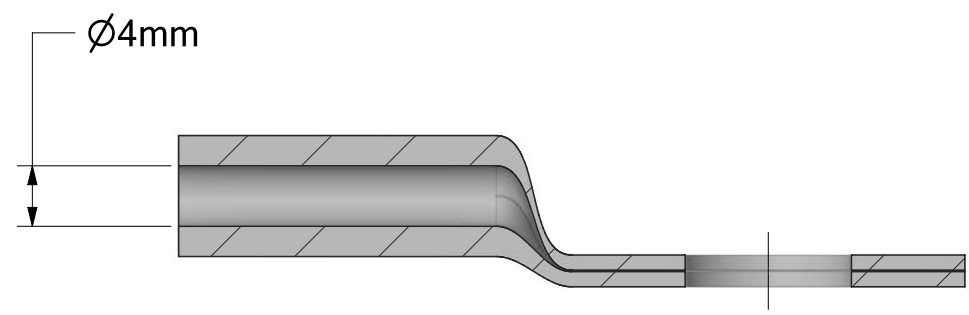

SECTION A-A

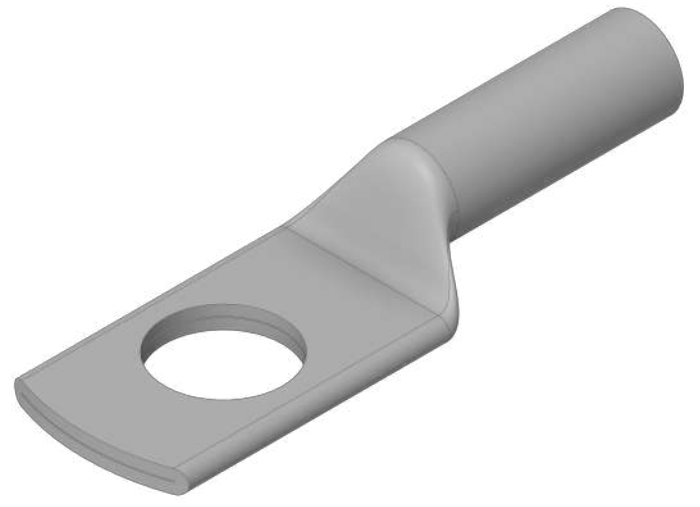
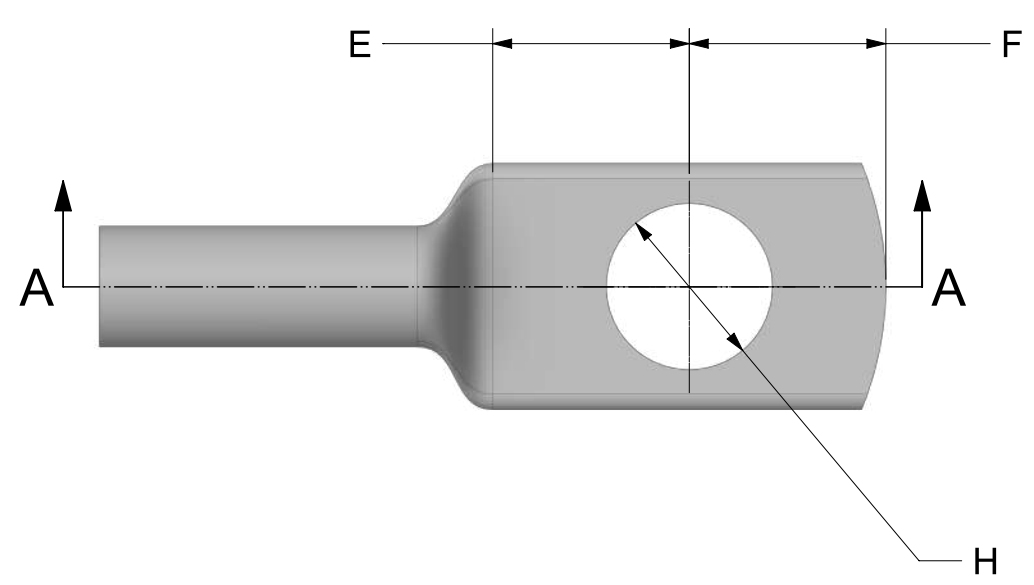
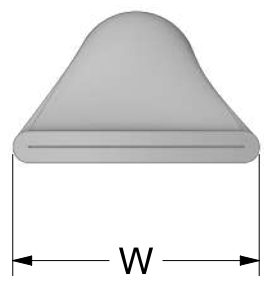

PART NO.	H (mm)	E (mm)	F (mm)	W (mm)
TCS1-6-3	3.5	13.5	13.5	16.3
TCS1-6-4	4.5	13.5	13.5	16.3
TCS1-6-5	5.5	13.5	13.5	16.3
TCS1-6-6	6.5	13.5	13.5	16.3
TCS1-6-8	8.5	13.5	13.5	16.3

UOS - LINEAR TOLERANCE PERMISSABLE DEVIATIONS FOR SIZE RANGE:
Tolerances according to DIN ISO 2768 (V)

DIMS IN MM	0.5 to 3	>3 to 6	>6 to 30	>30 to 120	>120 to 400	>400 to 1000	>1000 to 2000	>2000 to 4000
	-	±0.5	±1.0	±1.5	±2.5	±4.0	±6.0	±8.0

Drawing No. TCDR 2205		Material. SS316L	
Part No. TCS1-6-RANGE		Finish. N/A	
SIZE A3	Date 14/09/2021	Created By: Dan Hewlett	REV 2
SCALE 2:1			SHEET 1 of 1