

A2F-H

Ex db I/IIC, Ex eb I/IIC, Ex ta IIIC, Ex nR IIC

COMPRESSION GLAND for Unarmoured Cable



Features and Benefits

- For Group I, II, III, Zone 1, 2, 21 and 22 hazardous areas.
- Fitted with specially formulated elastomeric displacement seal, for superior cable retention, explosion protection and IP rating.
- A hose tail provides for clamping a protective hose over the cable.
- Precision manufactured from high-quality brass (Marine Grade Electroless Nickel Plated™) available in stainless steel 316/316L on request.
- Supplied with a thread sealing gasket (parallel threads only).



Technical Data

Type:	A2F-H
Gland Material:	Brass (Marine Grade Electroless Nickel Plated™), Stainless Steel 316/316L
Seal Material:	Standard Thermoset Elastomer or Extreme Temperature Seals
Sealing Gasket Material:	HDPE, Nylon 66 or PTFE
Cable Type:	Unarmoured
Sealing Area:	Outer Sheath
Optional Accessories:	Adaptor, Reducer, Earth Tag, Locknut, Serrated Washer and Shroud
Note:	The installer should ensure that the materials are suitable for the installation environment.

Standards and Certifications

Equipment Protection Levels:	IECEX/INMETRO: Ex db eb I Mb, Ex db eb IIC Gb, Ex nR IIC Gc, Ex ta IIIC Da ATEX/UKEX: Ⓢ I M2, II 2 GD, II 3G, Ex db eb I Mb, Ex db eb IIC Gb, Ex nR IIC Gc, Ex ta IIIC Da TR CU: Ⓢ 1Ex d IIC Gb X / PB Ex d I Mb X / 1Ex e IIC Gb X / PП Ex e I Mc X / 2Ex nR IIC Gc X / Ex tb IIIC Db X CCC: Ex db IIC Gb, Ex eb IIC Gb, Ex ta IIIC Da	
Continuous Operating Temp:	Standard Seals: -60°C to +95°C/100°C (HDPE/Nylon Sealing Gasket) Extreme Temp. Seals: -60°C to +160°C (PTFE Sealing Gasket)	
Conformance:	Standard:	Certificate:
IEC/BS EN	IEC/BS EN 62444, 6121	
IECEX	IEC 60079 Part 0, 1, 7, 15, 31	IECEX MSC 20.0002
ATEX	EN 60079 Part 0, 1, 7, 31	CML 20ATEX1026
	EN 60079 Part 0, 15	CML 16ATEX4002X
UKEX	BS EN 60079 Part 0, 1, 7, 31	CML 21UKEX1013
	BS EN 60079 Part 0, 15	CML 22UKEX4117
INMETRO (Brazil)	ABNT NBR IEC 60079 Part 0, 1, 7, 15, 31	TÜV 15.0483X
	TR CU (Russia)	ГОСТ P M3K 60079-0, 7, 1 5, 31 and ГОСТ IEC 60079-1
CCC/CNEx (Chinese)	GB/T3836.1, 2, 3, 31-2021	CNEx 21.3389X, CCC 2021312313000392
	SANS	SANS/IEC 60079 Part 0, 1, 7, 15, 31
IP66/68 850m - Parallel	IEC 60529	
IP65/66 - Tapered	IEC 60529	
IP68 – Tapered and approved grease	IEC 60529	
Deluge Protection	DTS-01	CML 14CA370-2
Corrosion Protection	ASTM B117-11, BS EN ISO 3231	EXOVA N968667
Marine ABS	IEC 60079 Part 0, 1, 7, 15, 31, IEC 60529	ABS 20-1952706-1-PDA
	DNV-GL	IEC 60079 Part 0, 1, 7, IEC 60529



Conditions for Safe Use - X

- The cable glands shall only be used where the temperature, at the point of entry, is between -60°C to +95°C (standard seal & HDPE sealing gasket), -60°C to +100°C (standard seal and Nylon sealing gasket) or -60°C to +160°C (extreme temp. seal & PTFE sealing gasket) depending on seal and gasket used.

Note: According to IEC 60079-14, 10.6.2: An Ex d gland will only maintain Ex d integrity when used with substantially round, compact and filled cable. If not a CCG VORTEX® barrier gland should be used.

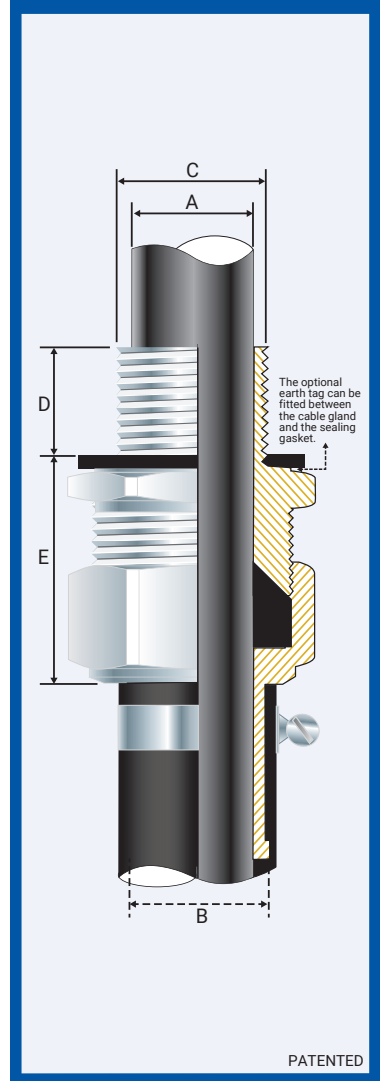

Product Code	Gland Size Reference	Metric Entry Thread		NPT Entry Thread		Cable Detail		Maximum Length 'E'	Spigot/Hose Tail 'B'	Hexagonal Detail		Install. Torque Value Nm
		'C'	Min 'D'	'C'	Min 'D'	Min 'A'	Max 'A'			Max 'Flats'	Max 'Crns'	
044900-16	00-16ss	M16x1.5	15	-	15	3.0	8.5	63.0	19.0	24.0	27.0	32.5
044900	00-20ss	M20x1.5	15	1/2/3/4	15	3.0	8.5	63.0	19.0	24.0	27.0	32.5
0449-0	0-20s	M20x1.5	15	1/2/3/4	15	7.0	12.0	63.0	19.0	24.0	27.0	32.5
044901	1-20	M20x1.5	15	1/2/3/4	15	11.0	14.5	77.0	19.0	27.0	30.0	32.5
044922	2s-25s	M25x1.5	15	3/4/1	15/19	11.5	17.5	77.5	25.4	35.0	39.0	47.5
044902	2-25	M25x1.5	15	3/4/1	15/19	15.0	20.0	77.5	25.4	35.0	39.0	47.5
044933	3s-32s	M32x1.5	15	1/1 1/4	19	16.0	22.0	91.0	31.8	42.0	47.0	55.0
044903	3-32	M32x1.5	15	1/1 1/4	19	20.0	26.5	91.0	31.8	42.0	47.0	55.0
044944	4s-40s	M40x1.5	15	1 1/4/1 1/2	19/21	22.0	31.5	109.0	38.1	52.0	59.0	65.0
044904	4-40	M40x1.5	15	1 1/4/1 1/2	19/21	26.0	34.0	109.0	38.1	52.0	59.0	65.0
044955	5s-50s	M50x1.5	15	1 1/2/2	21	29.0	38.0	136.0	50.8	65.0	73.0	82.5
044905	5-50	M50x1.5	15	1 1/2/2	21	34.0	44.5	136.0	50.8	65.0	73.0	82.5
044966	6s-63s	M63x1.5	15	2/2 1/2	21/30	38.0	50.0	161.0	63.5	80.0	90.0	97.5
044906	6-63	M63x1.5	15	2/2 1/2	21/30	44.5	56.5	161.0	63.5	80.0	90.0	97.5
044977	7s-75s	M75x1.5	15	2 1/2/3	30/32	50.0	62.0	181.0	76.0	96.0	108.0	115.5
044907	7-75	M75x1.5	15	2 1/2/3	30/32	56.0	67.5	181.0	76.0	96.0	108.0	115.5

All dimensions except NPT are in mm. Intermediate thread sizes are available on request. NPT threads should be tightened 'wrench tight'.

CCG reserves the right to make alterations to the technical data, dimensions, designs and products available without notice. The illustrations cannot be considered binding. Please contact CCG for assistance.

A2FH-HMG280323E

All Enquiries: tel: +44 (0)1744 762 929 | email: sales@etechcomponents.com | web: www.etechcomponents.com

© 2023 CCG CABLE TERMINATIONS (PTY) LTD

A2F-H GLAND

ENCLOSURES AND EQUIPMENT TO WHICH CABLE GLANDS ARE FITTED:-

- Must be made from materials which are compatible with the cable gland materials.
- Have a sealing area around the cable gland entry point with a surface roughness <math>< Ra 6.3 \mu m</math>.
- Have entries that are perpendicular to the enclosure face in the area where the cable gland will seal to within 2.5° .
- Are sealed using the supplied sealing gasket (parallel threads) or by fully tightening into a threaded entry (tapered threads). Note that for tapered threads the IP rating can be improved to IP68 with the use of a suitable thread sealant.

MUST HAVE THREADED ENTRIES

- The same thread size as the cable gland. (Thread adapters should be used to correct

any mismatch).

- With a thread tolerance of metric class '6H' or equivalent.
- Where the thread length is a minimum of 10mm for Ex d applications or 3mm for all other applications

OR CLEARANCE HOLES (not Ex d)

- Where the hole size is the thread nominal size with a tolerance of +0.1 to +0.7mm. (e.g. the clearance hole for an M20 thread will have a diameter between 20.1mm and 20.7mm).
- Through material that is between 1mm and 12mm thick. (Thicker materials can be accommodated using glands with extended entry threads.)

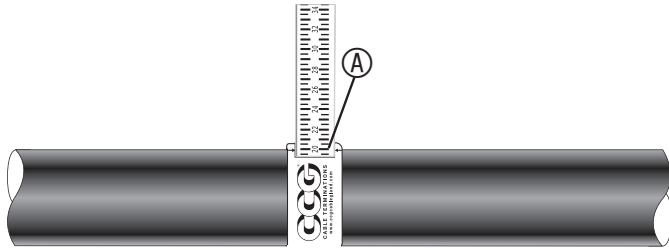

1. For accurate sizing, use a CCG Dimension Tape (A) on the outer cable sheath.

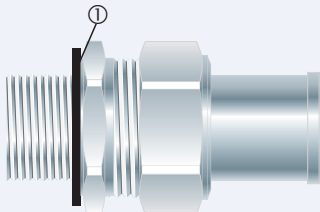

2. To maintain IP66/68 ensure the gasket (1) is in place.

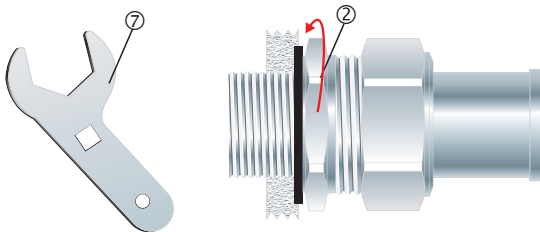

3. Screw the gland unit into the apparatus and tighten the inner (2) to the installation torque using a CCG Spanner (7).

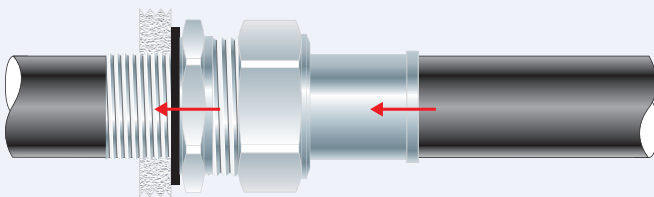

4. Pass the cable end through the gland assembly.

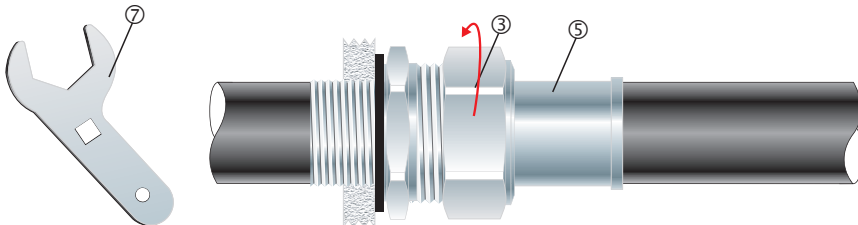

5. Tighten the outer nut (3) to produce an additional seal and grip on the cable the installation torque using a CCG Spanner (7).

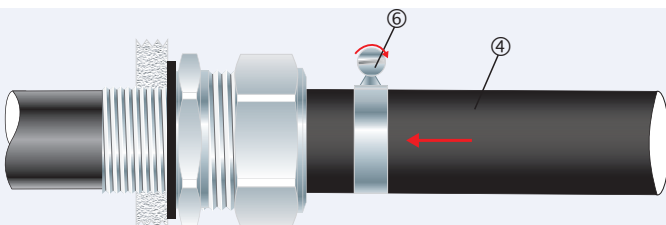

6. Slide the protective hose (4) over the hose tail (5) and tighten the hose clamp (6).