

# A2EX-VS

Ex db IIC, Ex eb IIC, Ex ta IIIC, Ex nR IIC

CABLE GLAND for Copper Tape, Braided or Lead-Sheathed Cable



### Features and Benefits

- Indoor, outdoor, Group II, III, Zone 1, 2, 20, 21 and 22 hazardous areas.
- The inner seal seals on the cable sheath.
- A harder outer seal grips the cable, giving it superior cable retention and an IP rating.
- Provides 360° earthing to copper tape or lead sheath.
- Precision manufactured from high-quality brass (Marine Grade Electroless Nickel Plated™), available in stainless steel 316/316L on request.
- Supplied with a thread-sealing gasket (parallel threads only).



### Technical Data

Type:	A2EX-VS
Glnd Material:	Brass (Marine Grade Electroless Nickel Plated™), Stainless Steel 316/316L
Seal Material:	Standard Thermoset Elastomer or Extreme Temperature Seals,
Sealing Gasket Material:	HDPE, Nylon 66 or PTFE
Cable Type:	Copper Tape, Braided or Lead Sheathed
Sealing Area:	Taper Seal on the Outer Sheath. Compression seal on inner copper sheath
Optional Accessories:	Adaptor, Reducer, Earth Tag, Locknut, Serrated Washer and Shroud
Note:	The installer should ensure that the materials are suitable for the installation environment.

### Standards and Certifications

Equipment Protection Levels:	IECEx/INMETRO: Ex db IIC Gb, Ex eb IIC Gb, Ex nR IIC Gc, Ex ta IIIC Da ATEX/UKEX: Ex II 2/3G 1D, Ex db IIC Gb, Ex eb IIC Gb, Ex nR IIC Gc, Ex ta IIIC Da TR CU: Ex I 1Ex d IIC Gb X / 1Ex e IIC Gb X / 2Ex nR IIC Gc X / Ex ta IIIC Da X CCC: Ex db IIC Gb, Ex eb IIC Gb, Ex ta IIIC Da	
Continuous Operating Temp:	Standard Seals: -60°C to +95°C/100°C (HDPE/Nylon Sealing Gasket) Extreme Temp. Seals: -60°C to +160°C (PTFE Sealing Gasket)	
Conformance:	Standard:	Certificate:
IEC/BS EN	IEC/BS EN 62444, 6121	CML 14CA364
IECEX	IEC 60079 Part 0, 1, 7, 15, 31	IECEX CML 20.0011
ATEX	EN 60079 Part 0, 1, 7, 31	CML 20ATEX1026
	EN 60079 Part 0, 15	CML 22ATEX4116
UKEX	BS EN 60079 Part 0, 1, 7, 31	CML 21UKEX1013
	BS EN 60079 Part 0, 15	CML 22UKEX4117
INMETRO (Brazil)	ABNT NBR IEC 60079 Part 0, 1, 7, 15, 31	TÜV 15.0483X
TR CU (Russia)	ГОСТ 31610-0, 15, ГОСТ IEC 60079-1	EAЭC RU C-ZA.HA91.B.00245/21
	ГОСТ P MЭК 60079-7, 31	
CCC/CNEx (Chinese)	GB/T3836.1, 2, 3, 31-2021	CNEx 21.3386X CCC 2021312313000395
SANS	SANS/IEC 60079 Part 0, 1, 7, 15, 31	MASC S/20-9022
IP66/68 100m - Parallel	IEC 60529	CML 15Y728
IP65 - Tapered	IEC 60529	
IP68 - Tapered and approved grease	IEC 60529	IECEX CML 20.0011
Deluge Protection	DTS-01	CML 14CA370-2
Corrosion Protection	ASTM B117-11, BS EN ISO 3231	EXOVA N968667
Marine ABS	IEC/EN 60079 Part 0, 1, 7, 15, 31	ABS 20-1952706-1-PDA
DNV-GL	IEC 60079 Part 0, 1, 7, IEC 60529	DNV-GL TAE0000010
EMC Compatible	EN 55011, + A1, EN 55022	SGS EMC305079/1

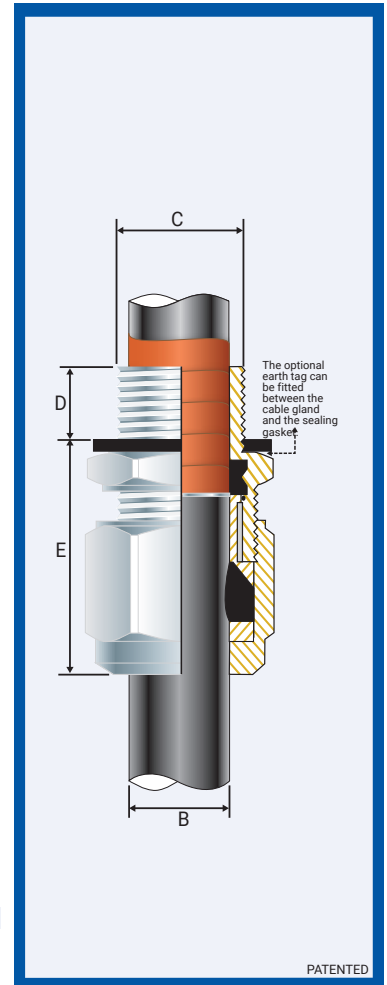

### Conditions for Safe Use - X

None.

Product Code	Glnd Size Ref	Metric Entry Thread		NPT Entry Thread		Cable Detail		Maximum Length 'E'	Hexagonal Detail		Install. Torque Value Nm
		'C'	Min 'D'	'C'	Min 'D'	Min 'B'	Max 'B'		Max 'Flats'	Max 'Crns'	
043600-16	00-16ss	M16x1.5	15	-	-	3.0	8.5	25.0	24.0	27.0	32.5
043600	00-20ss	M20x1.5	15	1/2/3/4	15	3.0	8.5	25.0	24.0	27.0	32.5
0436-0	0-20s	M20x1.5	15	1/2/3/4	15	7.0	12.0	25.0	24.0	27.0	32.5
043601	1-20	M20x1.5	15	1/2/3/4	15	11.0	15.0	30.0	27.0	30.0	32.5
043622	2s-25s	M25x1.5	15	3/4/1	15/19	11.5	17.5	30.0	35.0	39.0	47.5
043602	2-25	M25x1.5	15	3/4/1	15/19	15.0	20.0	30.0	35.0	39.0	47.5
043633	3s-32s	M32x1.5	15	1/1 1/4	19	16.0	22.0	30.0	42.0	47.0	55.0
043603	3-32	M32x1.5	15	1/1 1/4	19	20.0	26.5	30.0	42.0	47.0	55.0
043644	4s-40s	M40x1.5	15	1 1/4/1 1/2	19/21	22.0	31.5	38.0	52.0	59.0	65.0
043604	4-40	M40x1.5	15	1 1/4/1 1/2	19/21	26.0	34.0	38.0	52.0	59.0	65.0
043655	5s-50s	M50x1.5	15	1 1/2/2	21	29.0	38.0	46.0	65.0	73.0	82.5
043605	5-50	M50x1.5	15	1 1/2/2	21	34.0	44.5	46.0	65.0	73.0	82.5
043666	6s-63s	M63x1.5	15	2/2 1/2	21/30	38.0	50.0	52.0	80.0	90.0	97.5
043606	6-63	M63x1.5	15	2/2 1/2	21/30	44.5	56.5	52.0	80.0	90.0	97.5
043677	7s-75s	M75x1.5	15	2 1/2/3	30/32	50.0	62.0	54.0	96.0	108.0	115.5
043607	7-75	M75x1.5	15	2 1/2/3	30/32	56.0	67.5	54.0	96.0	108.0	115.5
043608	8-80	M80x2.0	20	3	32	59.0	69.0	68.0	96.0	108.0	120.0
043699	9s-90s	M90x2.0	20	3/3 1/2	32/33	60.0	75.0	70.0	111.0	125.0	120.0
043609	9-90	M90x2.0	20	3/3 1/2	32/33	73.0	81.5	70.0	111.0	125.0	120.0
043610	10-100	M100x2.0	20	3 1/2/4	33/34	81.0	91.0	70.0	125.0	141.0	120.0
043611	11-115	M115x2.0	20	4	34	91.0	101.0	70.0	135.0	152.0	175.0
043612	12-120	M120x2.0	20	-	-	101.0	109.0	70.0	140.0	158.0	175.0
043613	13-130	M130x2.0	20	-	-	109.0	116.0	70.0	146.0	164.0	175.0

All dimensions except NPT are in mm. Intermediate thread sizes are available on request. NPT threads should be tightened 'wrench tight'.

CCG reserves the right to make alterations to the technical data, dimensions, designs and products available without notice. The illustrations cannot be considered binding. Please contact CCG for assistance.

A2EXVS-GH010124E

### A2EX-VS GLAND

**ENCLOSURES AND EQUIPMENT TO WHICH CABLE GLANDS ARE FITTED:-**

- Must be made from materials which are compatible with the cable gland materials.
- Have a sealing area around the cable gland entry point with a surface roughness <math>< Ra 6.3 \mu m</math>.
- Have entries that are perpendicular to the enclosure face in the area where the cable gland will seal to within 2.5°.
- Are sealed using the supplied sealing gasket (parallel threads) or by fully tightening into a threaded entry (tapered threads). Note that for tapered threads the IP rating can be improved to IP68 with the use of a suitable thread sealant.

**MUST HAVE THREADED ENTRIES**

- The same thread size as the cable gland. (Thread adapters should be used to correct

any mismatch).

- With a thread tolerance of metric class '6H' or equivalent.
- Where the thread length is a minimum of 10mm for Ex d applications or 3mm for all other applications

**OR CLEARANCE HOLES (not Ex d)**

- Where the hole size is the thread nominal size with a tolerance of +0.1 to +0.7mm. (e.g. the clearance hole for an M20 thread will have a diameter between 20.1mm and 20.7mm).
- Through material that is between 1mm and 12mm thick. (Thicker materials can be accommodated using glands with extended entry threads.)

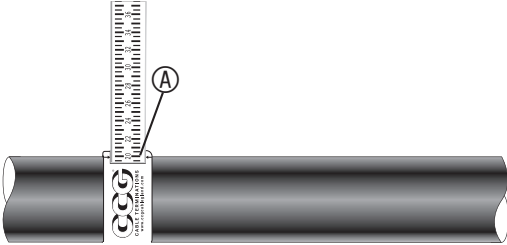

1. For accurate sizing, use a CCG Dimension Tape (A) on the outer cable sheath.

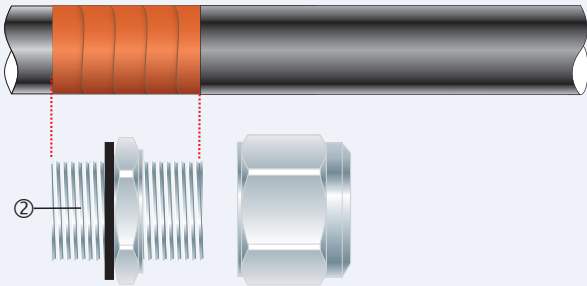

2. Cut the PVC sheath exposing the copper tape to the length of the inner (2).

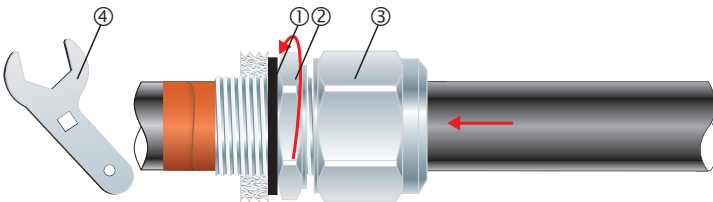

3. To maintain IP66/68, ensure the thread gasket (1) is in place. Screw the gland unit into the apparatus. Tighten the inner (2) using a CCG Spanner (4). Pass the cable end through the outer nut (3) and earth disc and seal.

Alternative installation through an unthreaded entry.

If the apparatus is untapped use a locknut.

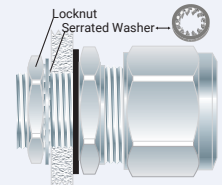

If the gland has NPT entry threads fitted to a threaded entry then IP68 (2m) can be achieved by applying one of the following tested and approved grease types to the thread:- Renolit Lubrene CA700 or LX220 EP2, Renolit LC-WP2 or Moly LX2, or Dow Corning 4 Electrical Compound.

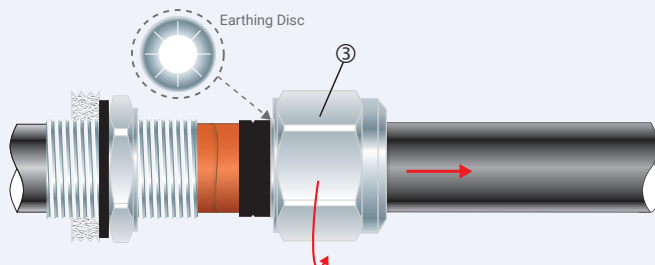

4. Unscrew the outer nut (3). Withdraw the cable. Check that the copper tape has passed through and makes 360° contact with the earthing disc.

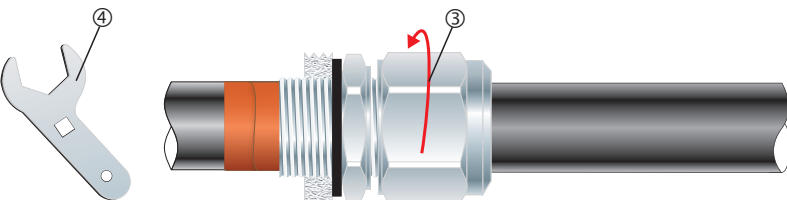

5. Tighten the outer nut (3) to the installation torque using a CCG Spanner (4) to produce a seal and grip on the cable.