

A2EX-VS VX

Ex db IIC, Ex eb IIC, Ex ta IIIC, Ex nR IIC

VORTEX BARRIER GLAND for Unfilled Unarmoured Copper Tape, Braided or Lead Sheathed Cable

Features and Benefits

- For indoors, outdoors Group II and III, Zone 1, 2, 20, 21 and 22 hazardous areas.
- For unfilled hygroscopic multicore cables refer to IEC 60079-14; 9.3.2 and 10.6.2a, IEC61892-7, 10.6 and 10.7
- Instantly mixed and injected Resin forms a 100% barrier seal around the individual cores of the cable.
- Prevents explosive gases and/or liquids transmitting down the cable.
- Inner seal seals on the cable sheath. Harder outer seal grips the cable giving superior cable retention and IP rating.
- Provides 360° earthing to copper tape or lead sheath.
- Precision manufactured from high-quality brass (Marine Grade Electroless Nickel Plated™) available in aluminium or stainless steel 316/316L on request.
- Supplied with a thread sealing gasket (parallel threads only).



Technical Data

Type:	A2EX-VS VX (VORTEX®)
Gland Material:	Brass (Marine Grade Electroless Nickel Plated™), Stainless Steel 316/316L
Seal Material:	Standard Thermoset Elastomer or Extreme Temperature Seals, Quick Setting Injection Barrier Resin Seal
Sealing Gasket Material:	HDPE, Nylon 66 or PTFE
Cable Type:	Unarmoured Copper Tape, Braided or Lead Sheathed
Sealing Area:	Taper Seal on the Outer Sheath. Compression seal on inner copper sheath. VORTEX® Resin around Cable Conductors
Optional Accessories:	Adaptor, Reducer, Earth Tag, Locknut, Serrated Washer and Shroud
Note:	The installer should ensure that the materials are suitable for the installation environment.

Standards and Certifications

Equipment Protection Levels:	IECEX/INMETRO: Ex db IIC Gb, Ex eb IIC Gb, Ex nR IIC Gc, Ex ta IIIC Da ATEX/UKEX: Ex II 2/3G 1D, Ex db IIC Gb, Ex eb IIC Gb, Ex ta IIIC Da, Ex nR IIC Gc TR CU: Ex db IIC Gb X / 1Ex e IIC Gb X / 2Ex nR IIC Gc X / Ex tb IIIC Db X CCC: Ex db IIC Gb, Ex eb IIC Gb, Ex ta IIIC Da	
Continuous Operating Temp:	-50°C to +95°C	
Conformance:	Standard: Certificate:	
IEC/BS EN	IEC/BS EN 62444, 6121	CML 14CA364
IECEX	IEC 60079 Part 0, 1, 7, 15, 31	IECEX CML 18.0018X
ATEX	EN 60079 Part 0, 1, 7, 31	CML 16ATEX1001X
	EN 60079 Part 0, 15	CML 16ATEX4002X
UKEX	BS EN 60079 Part 0, 1, 7, 31	CML 21UKEX1011X
	BS EN 60079 Part 0, 15	CML 21UKEX4006X
INMETRO (Brazil)	ABNT NBR IEC 60079 Part 0, 1, 7, 15, 31	TÜV 15.0483X
TR CU (Russia)	ГОСТ 31610-0, 15, ГОСТ IEC 60079-1	EA3C RU C-ZA.HA91.B.00245/21
	ГОСТ P M9K 60079-7, 31	
CCC/CNEx (Chinese)	GB/T3836.1, 2, 3, 31-2021	CNEx 21.3386X CCC 2021312313000395
SANS	SANS/IEC 60079 Part 0, 1, 7, 15, 31	MASC MS/22-9001X
IP66/68 100m - Parallel	IEC 60529	IECEX CML 18.0018X
IP65 - Tapered	IEC 60529	
IP68 - Tapered and approved grease	IEC 60529	IECEX CML 18.0018X
Deluge Protection	DTS-01	CML 14CA370-2
Corrosion Protection	ASTM B117-11, BS EN ISO 3231	EXOVA N968667
Marine ABS	IEC/EN 60079 Part 0, 1, 7, 15, 31 IEC 60529	ABS 20-1952706-1-PDA
DNV-GL	IEC 60079 Part 0, 1, 7, IEC 60529	DNV-GL TAE0000010
EMC Compatible	EN 55011, + A1, EN 55022	SGS EMC305079/1



Conditions for Safe Use - X

- The cable glands may only be used on fixed installations where the cable is clamped or stress applied to the cable in the gland is prevented.
- The cable glands shall only be used where the temperature, at the point of entry, is between -50°C and +95°C.
- Only Resin supplied by CCG may be used in the glands.

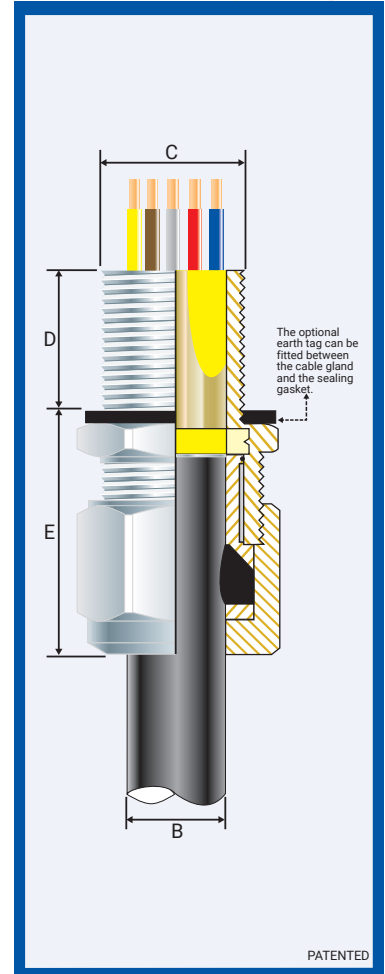

Product Code	Gland Size Ref	Metric Entry Thread		NPT Entry Thread		Cable Detail		Maximum Length 'E'	Max Dia. Over Cores	Max No. of Cores	Hexagonal Detail		Install. Torque Value Nm
		'C'	Min 'D'	'C'	Min 'D'	Min 'B'	Max 'B'				Max 'Flats'	Max 'Crns'	
056300-16-VX	00-16ss	M16x1.5	15	-	-	3.0	8.5	25.0	8.0	6	24.0	27.0	32.5
056300-VX	00-20ss	M20x1.5	15	1/2 3/4	15	3.0	8.5	25.0	10.9	10	24.0	27.0	32.5
05630-VX	0-20s	M20x1.5	15	1/2 3/4	15	7.0	12.0	25.0	10.9	10	24.0	27.0	32.5
056301-VX	1-20	M20x1.5	15	1/2 3/4	15	11.0	15.0	30.0	12.5	13	27.0	30.0	32.5
056322-VX	2s-25s	M25x1.5	15	3/4 1	15/19	11.5	17.5	30.0	15.5	20	35.0	39.0	47.5
056302-VX	2-25	M25x1.5	15	3/4 1	15/19	15.0	20.0	30.0	15.5	20	35.0	39.0	47.5
056333-VX	3s-32s	M32x1.5	15	1 1/4	19	16.0	22.0	30.0	21.7	40	42.0	47.0	55.0
056303-VX	3-32	M32x1.5	15	1 1/4	19	20.0	26.5	30.0	21.7	40	42.0	47.0	55.0
056344-VX	4s-40s	M40x1.5	15	1 1/4 1 1/2	19/21	22.0	31.5	38.0	30.0	60	52.0	59.0	65.0
056304-VX	4-40	M40x1.5	15	1 1/4 1 1/2	19/21	26.0	34.0	38.0	30.0	60	52.0	59.0	65.0
056355-VX	5s-50s	M50x1.5	15	1 1/2 2	21	29.0	38.0	46.0	36.3	80	65.0	73.0	82.5
056305-VX	5-50	M50x1.5	15	1 1/2 2	21	34.0	44.5	46.0	36.3	80	65.0	73.0	82.5
056366-VX	6s-63s	M63x1.5	15	2 1/2 3	21/30	38.0	50.0	52.0	47.9	100	80.0	90.0	97.5
056306-VX	6-63	M63x1.5	15	2 1/2 3	21/30	44.5	56.5	52.0	47.9	100	80.0	90.0	97.5
056377-VX	7s-75s	M75x1.5	15	2 1/2 3	30/32	50.0	62.0	54.0	58.2	120	96.0	108.0	115.5
056307-VX	7-75	M75x1.5	15	2 1/2 3	30/32	56.0	67.5	54.0	58.2	120	96.0	108.0	115.5
056308-VX	8-80	M80x2.0	20	3	32	59.0	69.0	68.0	61.5	140	96.0	108.0	120.0
056399-VX	9s-90s	M90x2.0	20	3 3/4 4	32/33	60.0	75.0	70.0	70.5	160	111.0	125.0	120.0
056309-VX	9-90	M90x2.0	20	3 3/4 4	32/33	73.0	81.5	70.0	70.5	160	111.0	125.0	120.0
056310-VX	10-100	M100x2.0	20	3 1/2 4	33/34	81.0	91.0	70.0	79.0	180	125.0	141.0	120.0
056311-VX	11-115	M115x2.0	20	4	34	91.0	101.0	70.0	-	-	135.0	152.0	175.0
056312-VX	12-120	M120x2.0	20	-	-	101.0	109.0	70.0	-	-	140.0	158.0	175.0
056313-VX	13-130	M130x2.0	20	-	-	109.0	116.0	70.0	-	-	146.0	164.0	175.0

All dimensions except NPT are in mm. Intermediate thread sizes are available on request. NPT threads should be tightened 'wrench tight'.

CCG reserves the right to make alterations to the technical data, dimensions, designs and products available without notice. The illustrations cannot be considered binding. Please contact CCG for assistance.

A2EXVS VRTX-BG030523E

All Enquiries: tel: +44 (0)1744 762 929 | email: sales@etechcomponents.com | web: www.etechcomponents.com

etech components

2023 © CCG CABLE TERMINATIONS (PTY) LTD

A2EX-VS VX (VORTEX[®]) BARRIER GLAND

ENCLOSURES AND EQUIPMENT TO WHICH CABLE GLANDS ARE FITTED:-

- Must be made from materials which are compatible with the cable gland materials.
- Have a sealing area around the cable gland entry point with a surface roughness <math>< Ra 6.3 \mu m</math>.
- Have entries that are perpendicular to the enclosure face in the area where the cable gland will seal to within 2.5°.
- Are sealed using the supplied sealing gasket (parallel threads) or by fully tightening into a threaded entry (tapered threads). Note that for tapered threads the IP rating can be improved to IP68 with the use of a suitable thread sealant.

MUST HAVE THREADED ENTRIES

- The same thread size as the cable gland. (Thread adapters should be used to correct

any mismatch).

- With a thread tolerance of metric class '6H' or equivalent.
- Where the thread length is a minimum of 10mm for Ex d applications or 3mm for all other applications

OR CLEARANCE HOLES (not Ex d)

- Where the hole size is the thread nominal size with a tolerance of +0.1 to +0.7mm. (e.g. the clearance hole for an M20 thread will have a diameter between 20.1mm and 20.7mm).
- Through material that is between 1mm and 12mm thick. (Thicker materials can be accommodated using glands with extended entry threads.)

1. Cut the PVC sheath exposing the copper tape to the length of the inner ②.

If the cable cores have screens these should be cut away or twisted together into a single core. This single core should be insulated with heat shrink tubing or coated with insulating varnish. Any drain wires should also be insulated with heat shrink tubing or coated with insulating varnish.

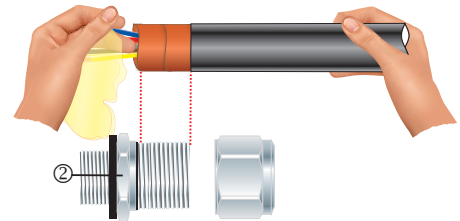

2. Using a clean cloth, clean the cable cores insulation. Using insulation tape, bundle the cores together at the end.

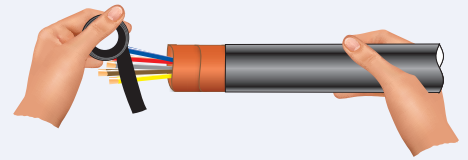

3. To maintain IP66/68, ensure the thread gasket ① is in place. Screw the gland unit into the apparatus. Tighten the inner ② using a CCG Spanner ⑨. Pass the cable end through the outer nut ③ and push the bundled cable cores through the inner ② diaphragm, earth disc and seal.

If the gland has NPT entry threads fitted to a threaded entry then IP68 (2m) can be achieved by applying one of the following tested and approved grease types to the thread:- Renolit Lubrene CA700 or LX220 EP2, Renolit LC-WP2 or Moly LX2, or Dow Corning 4 Electrical Compound.

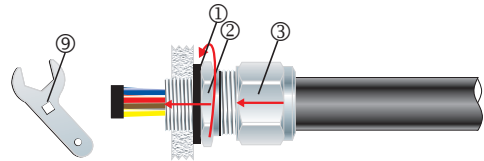

4. Unscrew the outer nut ③. Withdraw the cable and barrier pot sub-assembly ④. Remove the insulation tape. Check the copper tape has passed through and makes 360° contact with the earthing disc.

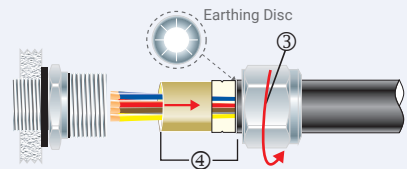

5. Remove the cap ⑦ from resin applicator and attach the mixing nozzle ⑧ (use extension nozzle for small multicore cables). Whilst holding the barrier pot sub-assembly ④ upright and holding the diaphragm seal firmly against the cable sheath inject the resin into the resin chamber*. Make sure the resin fills the inspectible resin seal pot ⑤ all the way to the top of the protective resin pot ⑥ and wipe any excess resin away.

Wait for the resin to set from a liquid to a gel, this should take:

- 15 minutes at 10°C
- 7 minutes at 20°C
- 6 minutes at 30°C
- 5 minutes at 40°C

For installations in less than 5°C Ambient, warm the Resin tube in warm water at ± 50°C. If there is Resin left in the tube, discard the mixing nozzle ⑧ and replace the cap ⑦ for use with the next gland.

* The installation is acceptable if the cable sheath is pushed 2mm or 3mm into the resin seal.



6. Re-insert the barrier pot sub-assembly ④ back into the inner ②.

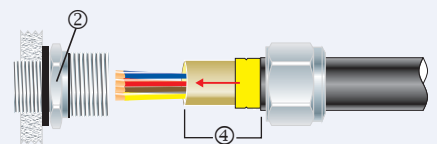

7. Tighten the outer nut ③ to the installation torque using a CCG Spanner ⑨ to produce a seal and grip on the cable.

