

Multicleat/Multistrap System 378AB Series



Multicleat and multistrap now use a new and improved locking mechanism making the installation quicker and easier. They also come with a disposable tensioning aid that was introduced in response to customer requests to improve the closure of the cleats and speed of installation. The adapter fits into the open end of the winding pin and is used with a standard 13mm socket wrench to tighten the strap. The same 13mm socket is then used to tighten the locking nut, finishing the installation.

Features and benefits

- Suitable for use with trefoil cable diameters 24 to 145mm.
- Suitable for use with single cable diameters 36 to 120mm.
- Large range take on each size.
- All straps manufactured from non-magnetic 316L Stainless Steel.
- Plain Aluminium bases - for normal industrial areas or outdoor unpolluted areas.
- Epoxy coated Aluminium versions available for harsher environments.
- Liners are made from LSOH materials.
- Suitable for single core cables laid in trefoil formation with high fault current capacities.
- Suitable for use with all standard ladder and tray systems.
- Suitable for groups of dissimilar cables.
- Tested in accordance with BS EN 61914 (IEC 61914)

Performance Data

BS EN 61914:2016 (IEC 61914:2015)	Clause	Classification
Type	6.1.3	Composite
Operating Temperature	6.2	-40°C to +120°C
Resistant to electromechanical forces, withstanding one short circuit	6.4.4	Standard duty strap (2 wraps): 57.3kA RMS, 126kA Peak, cleat spacing = 600mm, cable Ø = 38mm
Resistance to Corrosion	6.5.2.2	High, Outdoor - Wet unpolluted conditions
Resistant to ultraviolet light	6.5.1.2	Pass

	Clause	Classification
Resistant to electromechanical forces, withstanding more than one short circuit	6.4.5	Standard duty strap (2 wraps): 52.3kA RMS, 115kA Peak, cleat spacing = 600mm, cable Ø = 38mm
		Heavy duty strap (3 wraps): 55kA RMS, 121kA Peak, cleat spacing = 600mm, cable Ø = 38mm

* short circuit completed in conjunction with multistrap in a cleat-strap-cleat arrangement



Cable and Cleat Selection								Dimensions				Multistrap		
Design Number				Trefoil Cable Diameter		Single Cable Diameter		B Trefoil	B1 Single	C	D	Weight (kg)	Standard Strap	Heavy duty Strap
Aluminium base		Epoxy coated base		mm		mm		mm	mm	mm	mm			
Standard Strap	Heavy Duty Strap	Standard Strap	Heavy Duty Strap	Min	Max	Min	Max	Max	Max					
378AB01	378AB51	378AD01	378AD51	24	34	36	65	95	92	126	100	0.54	377AB01	377AB51
378AB02	378AB52	378AD02	378AD52	30	41	60	85	110	113	126	100	0.57	377AB02	377AB52
378AB03	378AB53	378AD03	378AD53	37	47	80	90	121	118	122	96	0.576	377AB03	377AB53
378AB04	378AB54	378AD04	378AD54	43	54	85	110	135	138	122	96	0.595	377AB04	377AB54
378AB05	378AB55	378AD05	378AD55	50	60	-	-	146	-	132	106	0.636	377AB05	377AB55
378AB06	378AB56	378AD06	378AD56	56	67	-	-	160	-	132	106	0.657	377AB06	377AB56
378AB07	378AB57	378AD07	378AD57	63	73	-	-	172	-	176	150	0.798	377AB07	377AB57
378AB08	378AB58	378AD08	378AD58	69	80	-	-	186	-	176	150	0.818	377AB08	377AB58
378AB09	378AB59	378AD09	378AD59	-	-	105	120	-	148	122	96	0.614	377AB09	377AB59
-	378AB36	-	378AD36	72	85	-	-	190	-	230	200	0.832	-	377AB36
-	378AB37	-	378AD37	82	95	-	-	210	-	230	200	0.864	-	377AB37
-	378AB38	-	378AD38	92	105	-	-	230	-	284	242	1.449	-	377AB38
-	378AB39	-	378AD39	102	115	-	-	250	-	284	242	1.48	-	377AB39
-	378AB40	-	378AD40	112	125	-	-	270	-	284	242	1.511	-	377AB40
-	378AB41	-	378AD41	122	135	-	-	290	-	284	242	1.542	-	377AB41
-	378AB42	-	378AD42	132	145	-	-	315	-	290	242	1.572	-	377AB42

* Technical Information subject to change without notice

Important note: To ensure adequate restraint, Multistrap MUST be used at the mid-point between cleats on all horizontal and vertical straight runs.

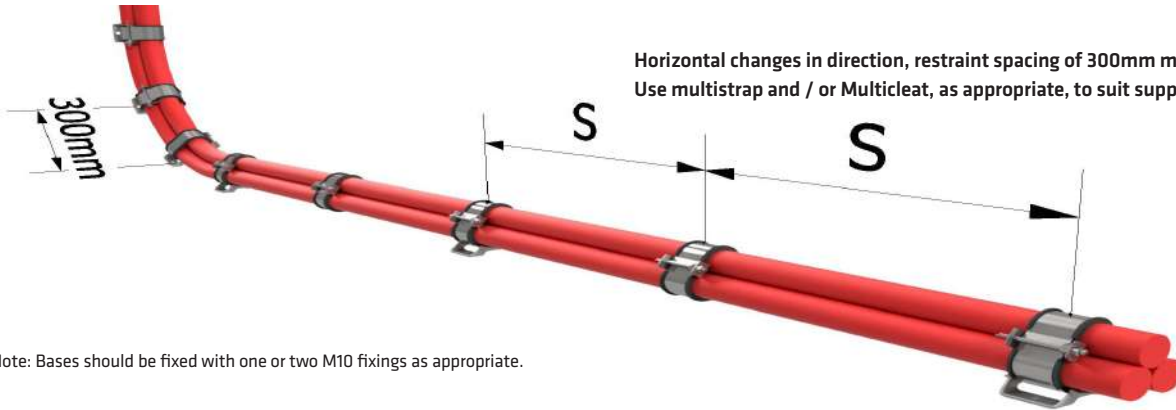

Note: Bases should be fixed with one or two M10 fixings as appropriate.

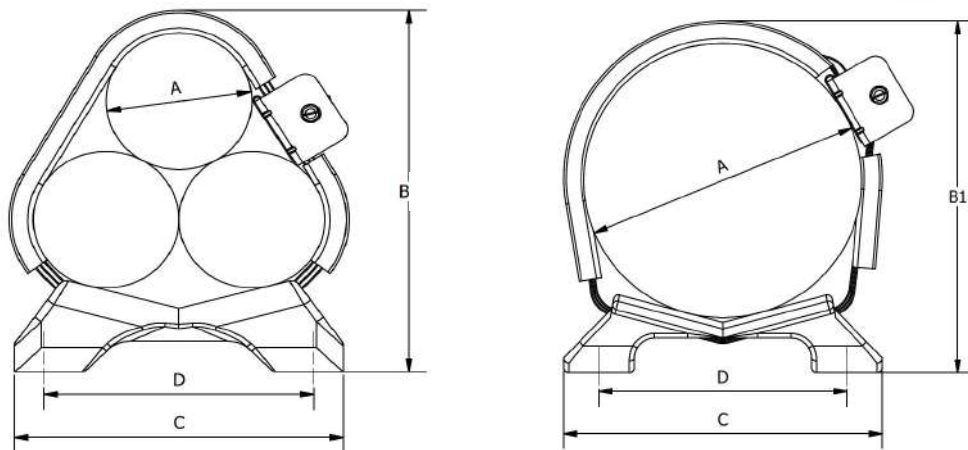

Prysmian Cables & Systems Limited,
Oak Road, Wrexham Industrial Estate, Wrexham, LL13 9PH, UK

Commercial Enquiries,
Sales Office Tel: 0845 767 8345,
International Sales Office Tel: +44 2380 295481