

Altus Cleat with Extension Arm and Swivel Base

370 Series



The Altus range - flexibility by design!

Features and benefits

- Suitable for use with cable diameters 50 to 152mm.
- Manufactured from aluminium alloy.
- Two-piece cleat design.
- Requires single M16 thread to be used to attach directly to cable ladder, tray or structure.
- Suitable for Low, Medium and High Voltage cables.
- Can be used for all types of cable routes.
- Cleat supplied with 5mm rubber liner as standard.
- Tested in accordance with IEC 61914:2015.
- Swivel base allows up to 45° variable angle in any direction.
- Arm slides into base to allow fine adjustment of final installation.

Performance Data

	Clause	Classification
Type	6.1.3	Composite
Operating Temperature	6.2	-60°C to 105°C
Impact Resistance	6.3.4	Heavy
Lateral Load	6.4.2	Orientation 2a: 12.6kN - 15.8kN Orientation 2c: 7.2kN - 8.2kN

	Clause	Classification
Axial Load	6.4.3	1kN - 3.5kN
Resistance to More Than One Short Circuit	6.4.5	25.8kA RMS, 64.4kA Peak, Ø = 74.4mm, spacing = 2000mm
Resistance to UV	6.5.1	Resistant to ultraviolet light
Resistance to Corrosion	6.5.2	High, Outdoor - wet conditions

* Technical Information subject to change without notice

**Prysmian
Draka
General Cable**

Technical Data

Cleat

Cable and Cleat Selection			Cleat Details			
Design Number	Cable Diameter		Dimensions (mm)			Weight (g)
	A (mm)		B (max)	C	D	
	Min	Max				
370FA10	50	62	104	104	50	529
370FA11	60	72	114	136	54	712
370FA12	70	82	116	140	64	835
370FA13	80	92	134.5	152	76	1043
370FA14	90	102	144.5	156	76	1096
370FA15	100	112	154.5	175	100	1431
370FA16	110	122	165.5	178	100	1622
370FA17	120	132	175.5	200	120	1963
370FA18	130	142	185.5	206	120	2099
370FA19	140	152	196	215	150	2540

* All fixings Bright Zinc Plated (BZP)

Arm

Arms			
Design Number	Dimensions (mm)		Weight (g)
	K	L	
Part only			
3702170	34.9	70	72
37021100	34.9	100	100
37021150	34.9	150	147
37021200	34.9	200	196
37021300	34.9	300	292
37021400	34.9	400	387
37021500	34.9	500	483
37021600	34.9	600	579

Base

Bases						
Design Number	Name	Dimensions (mm)			Fixing Size	Weight (g)
		H	I	J		
3702105	Swivel	35.9	154	100	M16	970

* All fixings Bright Zinc Plated (BZP)

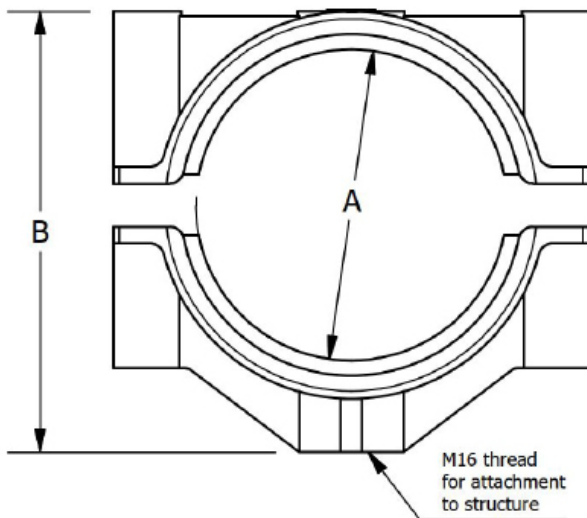
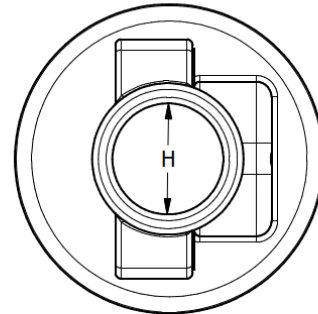
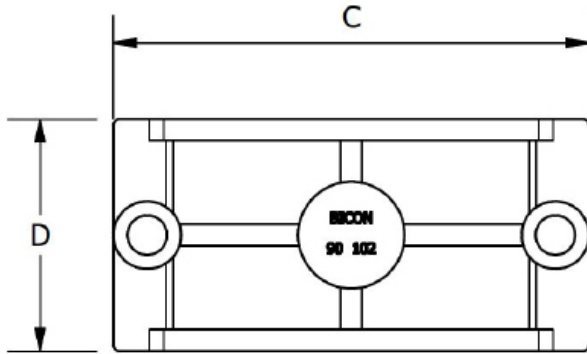

M16 thread
for attachment
to structure

Cleat

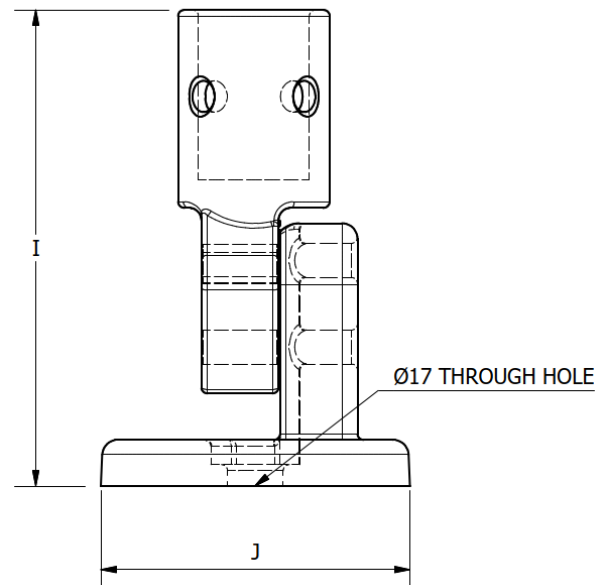

Swivel Base

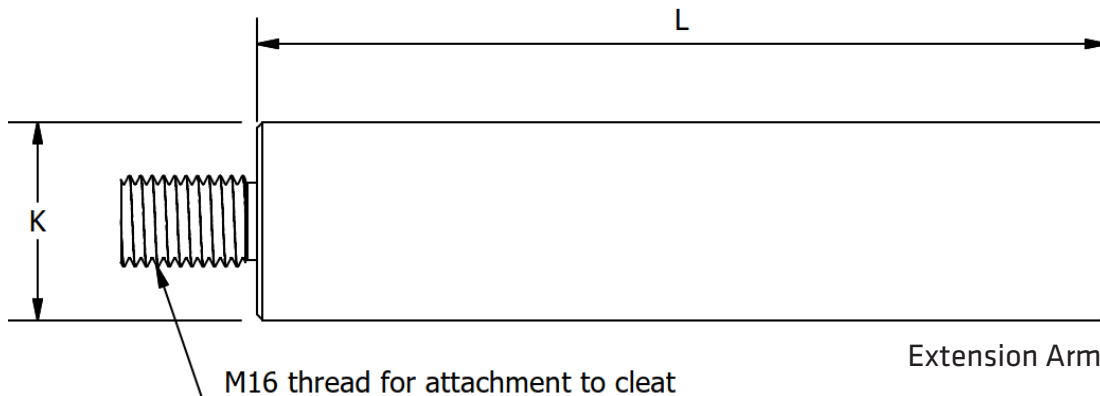

Extension Arm



Fully Assembled

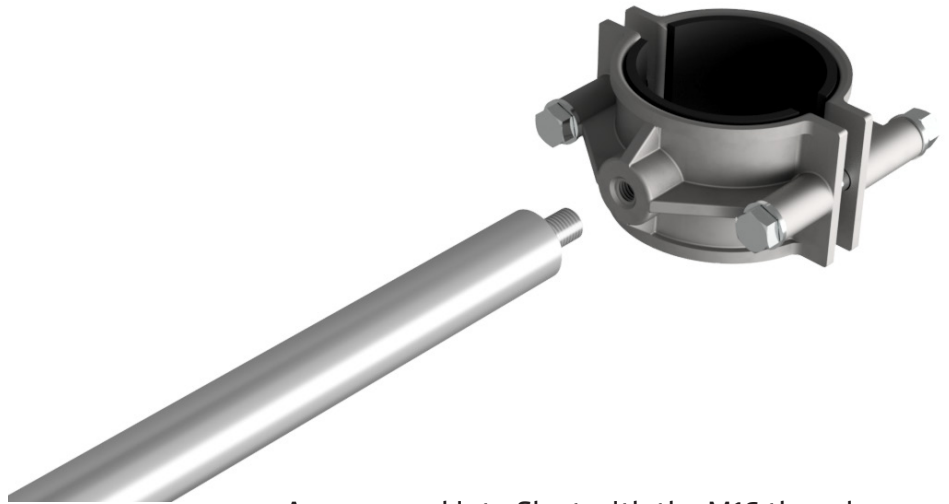

Arm secured into Cleat with the M16 thread.



Extension Arm

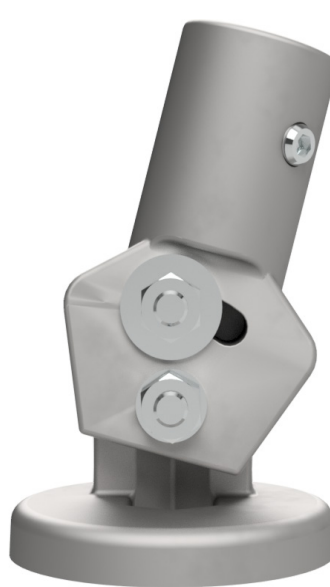

Swivel Base

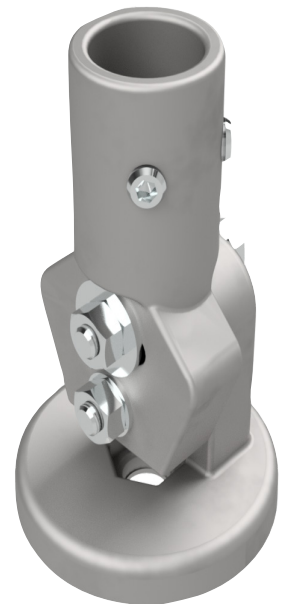

Prysmian Cables & Systems Limited,
Oak Road, Wrexham Industrial Estate, Wrexham, LL13 9PH, UK

Commercial Enquiries,
Sales Office Tel: 0845 767 8345,
International Sales Office Tel: +44 2380 295481

www.biconcomponents.co.uk

**Prysmian
Draka
General Cable**