

# ELLIS

Holding Power

# VULCAN™



## INSTALLATION INSTRUCTIONS

1

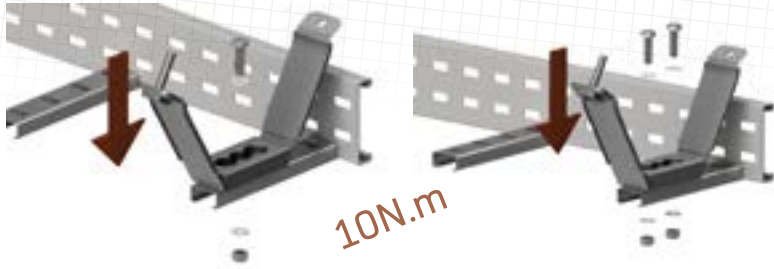

**MOUNTING**

Place the cleat onto the mounting surface and secure.

2



**PAD**

Insert the appropriate pad as required.



Refer to the cleat label to determine the correct base pad, dependant on your cable diameter.

3

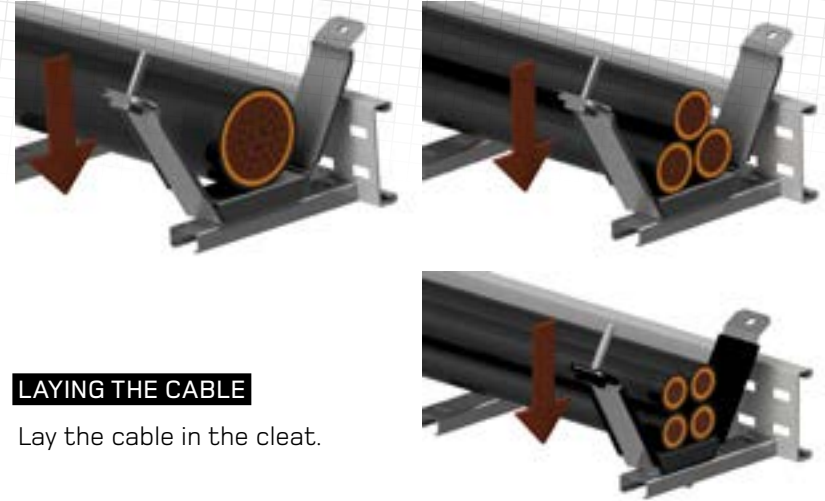

**LAYING THE CABLE**

Lay the cable in the cleat.

4

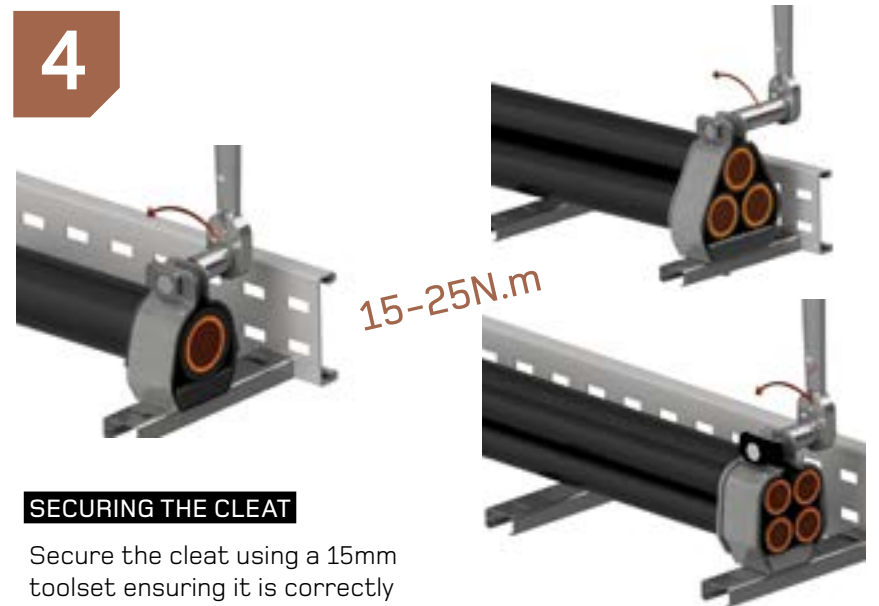

**SECURING THE CLEAT**

Secure the cleat using a 15mm toolset ensuring it is correctly torqued.

# CABLE TORQUE

The cleat's appropriate tightening torque can depend on the cable type. Lower torques are more appropriate for unarmoured cables with soft outer sheaths and higher torques are more applicable for large armoured cables. The table below provides torque guidelines. These figures should be used as a guide only and care should always be taken on sight to ensure the cable is not damaged by excessive tightening.

**PARALLEL FLANGES:** Providing the cleat can be tightened with a minimum of two thread pitches protruding past the nut, the installation is suitable. The flanges do not have to meet up or be parallel, providing they are bolted together with a sufficient exposed thread.

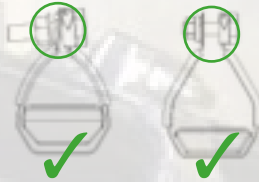

CABLE TYPE	SUGGESTED TORQUE
CLASS 5 CONDUCTOR UNARMoured	15 N.m
DOUBLE INSULATED (UNARMoured) PVC CABLE	20 N.m
STEEL/ALUMINIUM WIRE ARMoured CABLE	25 N.m
METALLIC SHEATH XLPE HV CABLE	25 N.m

**Please note:** Thread galling is a known phenomenon that occurs when using stainless steel fasteners. A breakdown in the material's protective oxide layer results in the set screw and nut becoming welded together. To reduce the incidence of thread galling, please avoid excessive speed and pressure during installation. Thread lubricants can also be used at the point of application. If you have any problems, please contact Ellis Patents for further information.



Conduit & cable hardware  
4CG8 with AH-2 & wet  
locations.

Range listed as follows:  
VRT+00 to VRT+18 &  
VRQ+01 to VRQ+09.

<b>Mounting orientation:</b> Horizontal or Vertical.
UL bolt torque values:  <b>VRT+06: 70 lbf-in</b>
<b>VRQ+03: 35 lbf-in</b>  <b>Note:</b> UL bolt torque values may not represent the most ideal bolt torque setting for your cable.