

# HRST Family

Hawke HRST is a round sealing solution for a single cable/pipe passing through a wall or bulkhead/deck

Each size of HRST frame can seal a large range of diameters without any onsite modifications.

## CHARACTERISTICS

- ◆ Available to seal services from 4mm up to 170mm of external diameter (standard version).
- ◆ Tolerant up to 7 mm.
- ◆ Designed to be installed using Hawke Sleeves (welded, bolted or casted).
- ◆ Manufactured in intumescent elastomer polymer with stainless steel front and back plates. Each HRST frame has a gasket to prevent galvanic corrosion when installed within a mild steel sleeve.
- ◆ HRST is always supplied as an open frame. This enables the frame to be installed after cable/pipe installation.
- ◆ No extra tools are required for its installation.

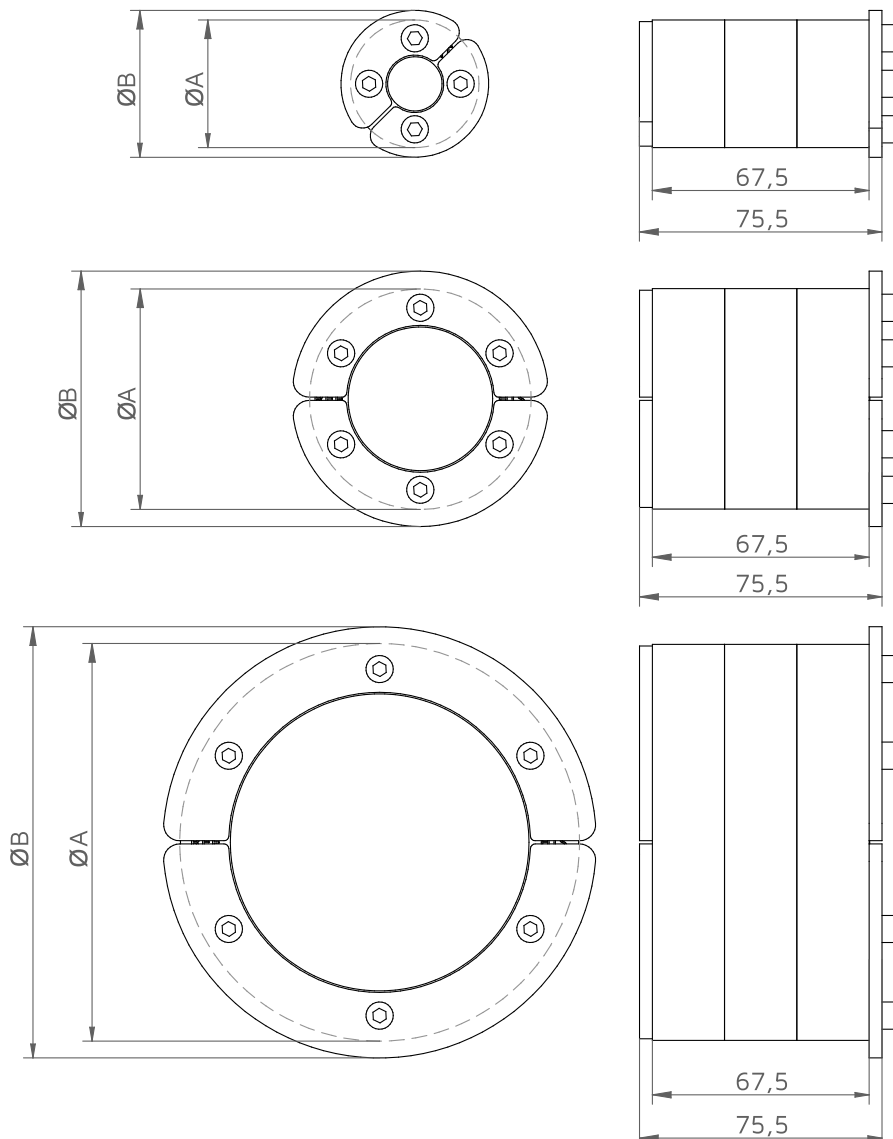

# HRST Family

DESCRIPTION	SLEEVE SIZE NEEDED	SEALING FROM (mm)	SEALING TO (mm)	A (mm)	B (mm)	WEIGHT (kg)	COLOUR
HRST-30/4	30	4	10	32	36	0,16	White
HRST-30/7	30	7	14	32	36	0,15	Red
HRST-30/10	30	10	17	32	36	0,14	Blue
HRST-40/4	40	4	10	40	46	0,24	Purple
HRST-40/7	40	7	14	40	46	0,23	yellow
HRST-40/10	40	10	17	40	46	0,21	Green
HRST-40/17	40	17	24	40	46	0,18	Pink
HRST-50/4	50	4	10	50	56	0,35	Red
HRST-50/10	50	10	17	50	56	0,33	White
HRST-50/17	50	17	24	50	56	0,29	Blue
HRST-50/24	50	24	30	50	56	0,25	Orange
HRST-70/26	70	26	33	69	80	0,56	Purple
HRST-70/33	70	33	39	69	80	0,50	Yellow
HRST-70/39	70	39	45	69	80	0,44	Green
HRST-70/45	70	45	50	69	80	0,38	Pink
HRST-100/48	100	48	55	99	110	0,96	Red
HRST-100/55	100	55	61	99	110	0,87	White
HRST-100/61	100	61	66	99	110	0,79	Blue
HRST-100/66	100	66	71	99	110	0,71	Orange
HRST-125/64	125	64	71	124	135	1,42	Purple
HRST-125/71	125	71	79	124	135	1,27	Yellow
HRST-125/79	125	79	86	124	135	1,12	Green
HRST-125/86	125	86	93	124	135	0,96	Pink
HRST-125/93	125	93	98	124	135	0,84	Orange
HRST-150/93	150	93	102	149	160	1,79	Red
HRST-150/102	150	102	108	149	160	1,63	White
HRST-150/108	150	108	115	149	160	1,43	Blue
HRST-150/115	150	115	120	149	160	1,28	Orange
HRST-175/118	175	118	125	174	185	2,16	Purple
HRST-175/125	175	125	132	174	185	1,93	Yellow
HRST-175/132	175	132	138	174	185	1,72	Green
HRST-175/138	175	138	145	174	185	1,47	Pink
HRST-200/136	200	136	143	199	210	2,73	Red
HRST-200/143	200	143	150	199	210	2,48	White
HRST-200/150	200	150	157	199	210	2,20	Blue
HRST-200/157	200	157	164	199	210	1,92	Orange
HRST-200/164	200	164	170	199	210	1,67	Yellow

\*All dimensions are nominal values

## Installation references

	page
See accessories	76
See installation guide	122
See inspection check	162

# HRST 40 2D15

Hawke HRST multihole designed for the sealing of up to 2 cables with an external diameter between 10 and 15 mm.



Empty cable space to be filled with Plug HRST 2D15

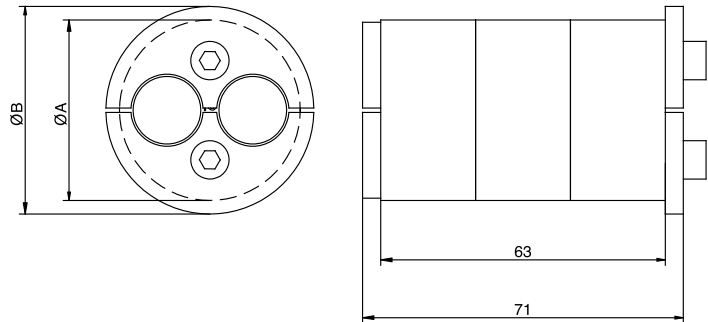

DESCRIPTION	SLEEVE SIZE NEEDED	NUMBER OF CABLES	SEALING FROM (mm)	SEALING TO (mm)	A (mm)	B (mm)	NUMBER OF BOLT	BOLT SIZE	WEIGHT (kg)
HRST 40 2D15	40	2	10	15	40	46	2	M5	0,17
Plug HRST 2D15				-					0,02

# HRST 40 4D12

Hawke HRST multihole designed for the sealing of up to 4 cables with an external diameter between 8 and 12 mm.



Empty cable space to be filled with Plug HRST 4D12

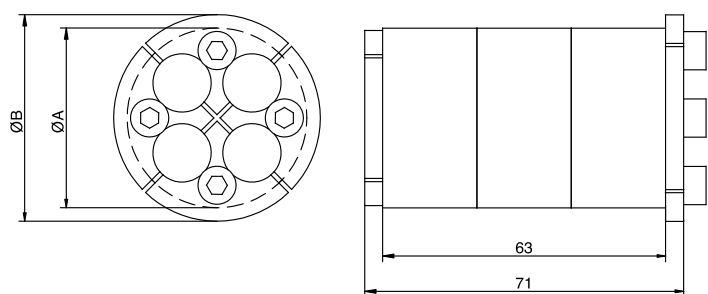

DESCRIPTION	SLEEVE SIZE NEEDED	NUMBER OF CABLES	SEALING FROM (mm)	SEALING TO (mm)	A (mm)	B (mm)	NUMBER OF BOLT	BOLT SIZE	WEIGHT (kg)
HRST 40 4D12	40	4	8	12	40	46	4	M5	0,16
Plug HRST 4D12				-					0,02

→ Installation references

	page
See accessories	76
See installation guide	124
See inspection check	163